

# GESAMTPROGRAMM RANGE OF PRODUCTS



made  
in  
Germany



Guten Tag,

als geschäftsführender Gesellschafter der bereits in der dritten Generation familiengeführten Bänninger Kunststoff-Produkte GmbH freuen wir uns über Ihr Interesse an unseren Produkten.

In guter Tradition des Unternehmens fühlen wir uns in besonderer Weise unseren Kunden in aller Welt verpflichtet. Sie können wie bisher auf Bänninger Qualität „Made in Germany“ und auf eine partnerschaftliche und faire Zusammenarbeit vertrauen.

Dieses Versprechen beinhaltet auch eine klare Orientierung an Werten. Die strikte Einhaltung ethischer Prinzipien, Wertschätzung der Mitarbeiterinnen und Mitarbeiter und ein nachhaltiger Umgang mit Natur und Ressourcen sind Teil unserer Unternehmenskultur.

Nutzen Sie über die Lieferung von Produkten hinaus auch unser Angebot an Beratung und Betreuung. Lassen Sie uns im Dialog bleiben.

Auch auf [www.baenninger.de](http://www.baenninger.de).

Wir sind für Sie da.

Hello,

as the Managing Partners of Bänninger Kunststoff-Produkte GmbH, which is under its third generation of family management, we are pleased about your interest in our products.

In keeping with the company's tradition, we feel committed to our customers all over the world in a special way. You can continue to trust in Bänninger quality „Made in Germany“ and a partnership and fair cooperation.

This promise also includes a clear orientation towards values. Strict compliance with ethical principles, the appreciation of employees and sustainable handling of nature and resources are part of our corporate culture.

Also take advantage of our advisory and support services, over and above the delivery of products. Let us keep up a dialogue.

Also at [www.baenninger.de](http://www.baenninger.de).

We are here for you.

Edgar Ertl

Hendrik Ertl

Christoph Stamm

Neue Teilenummern • New Item Numbers

Wir messen der Anpassung an die aktuellen Marktgegebenheiten größte Beachtung bei und haben beschlossen moderner, entschlossener zu werden. Dazu gehören eindeutige Artikelnummern. Diese versuchen wir Ihnen im Folgenden nahe zu bringen.

Alle BR-Verkaufsartikel erhalten eine neue 10-stellige und für alle Produktbereiche einheitlich aufgebaute Artikelnummer die aus 3 Blöcken (4 4 2) besteht.

Um bei Bestellungen Verwechslungen auszuschließen ist diese Artikelnummer immer vollständig anzugeben.

We obey Market development and conditions, so we decided to demonstrate modernity and a decisive strategy. To facilitate ordering with us, please find the following explanation of our new item number system.

All BR sales items receive a new 10-digit article number, which consists of 3 blocks (4 4 2), which is uniform for all product groups.

In order to exclude confusion when placing orders, this item number must always be specified completely.

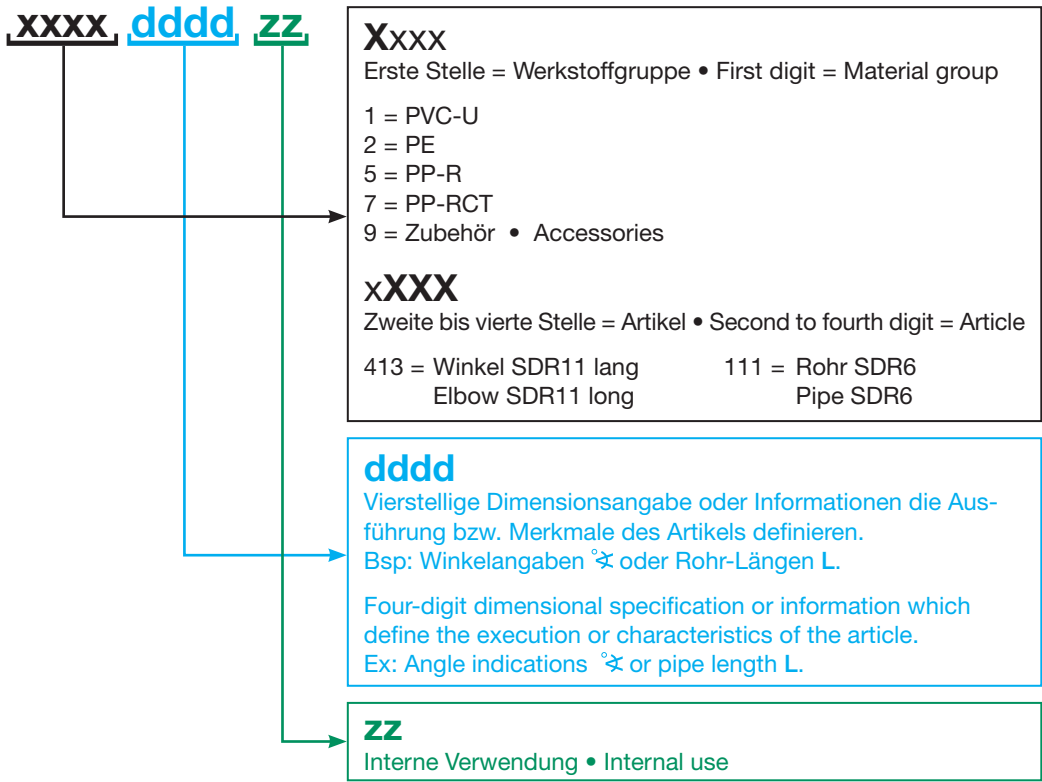

Bestellbeispiel • Order example 1

PE100 Winkel 90° lang SDR11 schwarz D125  
PE100 Elbow 90° long SDR11 black D125

**2413 15 90 15**

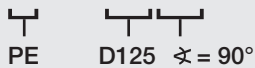

Bestellbeispiel • Order example 2

PP-R Rohr G 8200 SDR 6 grün 4m D50  
PP-R Pipe G 8200 SDR 6 green 4m D50

**5111 10 40 11**

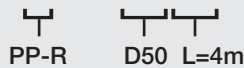

Zählweise bei Formteilen mit Abgängen  
Counting at fittings with outlets

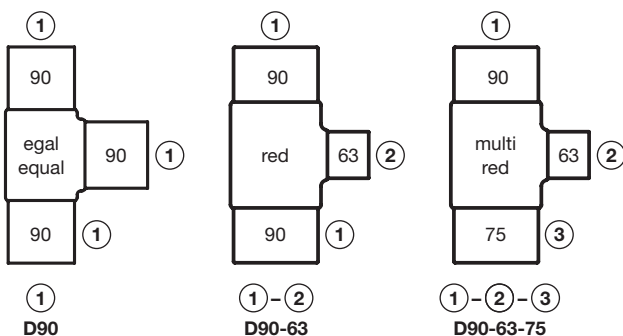

i Dimension

mm	Code	Inch	fem	male
		Zoll	IG	AG
6	01	1/8	40	70
8	02	1/4	41	71
10	03	3/8	42	72
12	04	1/2	43	73
16	05	5/8	44	74
20	06	3/4	45	75
25	07	1	46	76
32	08	1 1/4	47	77
40	09	1 1/2	48	78
50	10	1 3/4	49	79
63	11	2	50	80
75	12	2 1/4	51	81
90	13	2 3/8	52	82
110	14	2 1/2	53	83
125	15	2 3/4	54	84
140	16	3	55	85
160	17	3 1/2	56	86
180	18	4	57	87
200	19	5	58	88
225	20	6	59	89
250	21	7	60	90
280	22	8	61	91
315	23	10	62	92
355	24	12	63	93
400	25			
450	26			
500	27			
560	28			
630	29			
710	30			
800	31			
900	32			
1000	33			

<b>i INFO</b>	<b>i INFO</b>		<b>i 1</b>
	▪ Neue Teilenummern • New Item Numbers		i 1
	▪ Zählweise bei Formteilen mit Abgängen • Counting at fittings with outlets		i 1
	▪ Bänninger-Erfolgsstory • Bänninger A Success Story		i 4
<b>PVC-U</b>	<b>1 PVC-U</b>		<b>PVC 1</b>
	1.01 Bögen + Winkel • Bends + Elbows		PVC 5
	1.02 T-Stücke + Abzweige • Tee's + Branches		PVC 6
	1.03 Reduktionen, Muffen, Kappen • Reducers, Sockets, Caps		PVC 7
	1.04 Übergänge • Transitions		PVC 10
	1.05 Verschraubungen • Unions		PVC 13
	1.06 Flanschverbindung • Flange connection		PVC 18
	1.07 Formteile mit Kunststoff-Gewinde • Fittings with plastic-thread		PVC 21
	1.08 Kugelhähne • Ball valves		PVC 22
	1.09 Ventile • Valves		PVC 24
<b>PE 100</b>	<b>2 PE100</b>		<b>PE 1</b>
	<b>2.01 Formteile lang • Fittings long</b>		<b>PE 4</b>
	2.01.01 Winkel lang • Elbows long		PE 4
	2.01.02 T-Stücke + Abzweige lang • Tee's + Branches long		PE 6
	2.01.03 Reduktionen + Kappen lang • Reducers + Caps long		PE 9
	2.01.04 Übergänge lang • Transitions long		PE 12
	2.01.05 Verschraubungen lang • Unions long		PE 13
	2.01.06 Flanschverbindung lang • Flange connection		PE 15
	2.01.07 Kugelhähne lang • Ball Valves long		PE 20
	<b>2.02 Formteile kurz • Fittings short</b>		<b>PE 21</b>
	2.02.01 Bögen + Winkel kurz • Bends + Elbows short		PE 21
	2.02.02 T-Stücke kurz • Tee's short		PE 23
	2.02.03 Reduktionen kurz • Reducers short		PE 24
	2.02.04 Übergänge kurz • Transitions short		PE 26
2.02.05 Flanschverbindung kurz • Flange connection short		PE 27	
<b>2.03 E-Formteile • E-Fittings</b>		<b>PE 29</b>	
<b>2.04 Bögen nahtlos • Bends seamless</b>		<b>PE 32</b>	
<b>PP-R</b>	<b>3 PP-R</b>		<b>PPR 1</b>
	<b>3.01 Rohre einlagig • Pipes single-layer</b>		<b>PPR 4</b>
	<b>3.02 Formteile Muffen-Schweißen • Fittings socket-welding</b>		<b>PPR 7</b>
	3.02.01 Bögen + Winkel • Bends + Elbows		PPR 7
	3.02.02 T-Stücke + Abzweige • Tee's + Branches		PPR 9
	3.02.03 Reduktionen, Muffen, Kappen • Reducers, Sockets, Caps		PPR 10
	3.02.04 Übergänge • Transitions		PPR 11
	3.02.05 Übergänge Wand • Transitions wall		PPR 13
	3.02.06 Verschraubungen • Unions		PPR 15
	3.02.07 Flanschverbindung • Flange connection		PPR 18
	3.02.08 Verteiler • Manifolds		PPR 19
3.02.09 Kugelhähne • Ball valves		PPR 20	
3.02.10 Ventile • Valves		PPR 21	
<b>PP-RCT</b>	<b>4 PP-RCT</b>		<b>RCT 1</b>
	<b>4.01 Rohre • Pipes</b>		<b>RCT 4</b>
	4.01.01 Rohre einlagig • Pipes single-layer		RCT 4
	4.01.02 Rohre mehrlagig • Pipes multi-layer		RCT 7
	4.01.03 Sonderrohre • Special Pipes		RCT 10
	<b>4.02 Formteile Muffen-Schweißen • Fittings socket-welding</b>		<b>RCT 12</b>
	4.02.01 Bögen + Winkel • Bends + Elbows		RCT 12
	4.02.02 T-Stücke + Abzweige • Tee's + Branches		RCT 14
	4.02.03 Reduktionen, Muffen, Kappen • Reducers, Sockets, Caps		RCT 16
	4.02.04 Übergänge • Transitions		RCT 17
	4.02.05 Übergänge Wand • Transitions wall		RCT 19
	4.02.06 Verschraubungen • Unions		RCT 21
	4.02.07 Flanschverbindung • Flange connection		RCT 24
	4.02.08 Einschweißsättel • Weld-in-saddles		RCT 25
4.02.09 Verteiler • Manifolds		RCT 27	
4.02.10 Kugelhähne • Ball valves		RCT 28	
4.02.11 Ventile • Valves		RCT 29	
<b>4.03 Formteile Stumpf-Schweißen • Fittings butt-welding</b>		<b>RCT 31</b>	
4.03.01 Winkel • Elbows		RCT 31	
4.03.02 T-Stücke • Tee's		RCT 32	
4.03.03 Reduktionen, Kappen • Reducers, Caps		RCT 33	
4.03.04 Flanschverbindung • Flange connection		RCT 34	
<b>4.04 Formteile Heizwendel-Muffen-Schweißen • Fittings electrofusion-socket-welding</b>		<b>RCT 36</b>	

<b>PP-INDUSTRIAL</b>	<b>5 PP-INDUSTRIAL</b>	<b>IND 1</b>	
	<b>5.01 Rohre • Pipes</b>	<b>IND 4</b>	
	5.01.01 Rohre einlagig • Pipes single-layer	IND 4	
	5.01.02 Rohre mehrlagig • Pipes multi-layer	IND 6	
	<b>5.02 Formteile Muffen-Schweißen • Fittings socket-welding</b>	<b>IND 7</b>	
	5.02.01 Winkel • Elbows	IND 7	
	5.02.02 T-Stücke + Abzweige • Tee's + Branches	IND 8	
	5.02.03 Reduktionen, Muffen, Kappen • Reducers, Sockets, Caps	IND 9	
	5.02.04 Verschraubungen • Unions	IND 10	
	5.02.05 Flanschverbindung Muffe • Flange connection socket	IND 11	
	5.02.06 Kugelhähne • Ball Valves	IND 12	
	<b>5.03 Formteile Stumpf-Schweißen • Fittings butt-welding</b>	<b>IND 13</b>	
	5.03.01 Bögen + Winkel • Bends + Elbows	IND 13	
	5.03.02 T-Stücke • Tee's	IND 14	
	5.03.03 Reduktionen • Reducers	IND 15	
	5.03.04 Übergänge • Transitions	IND 16	
5.03.05 Verschraubungen • Unions	IND 17		
5.03.06 Flanschverbindung • Flange connection	IND 19		
<b>5.04 Armaturen • Valves</b>	<b>IND 13</b>		
<hr/>			
<b>ZUBEHÖR</b>	<b>6 Zubehör • Accessories</b>	<b>ZUB 1</b>	
	<b>6.01 Flansche • Flanges</b>	<b>ZUB 2</b>	
	6.01.01 Losflansche DIN-EN • Flanges DIN-EN	ZUB 2	
	6.01.02 Losflansche ANSI • Flanges ANSI	ZUB 5	
	6.01.03 Sonder-Flanschverbindung • Special Flange connection	ZUB 7	
	<b>6.02 Dichtungen • Gaskets</b>	<b>ZUB 9</b>	
	6.02.01 Runddichtringe • O-Ring-Gaskets	ZUB 9	
	6.02.02 Flachdichtringe • Flat-Gaskets	ZUB 9	
	6.02.03 Flachdichtringe mit Stahleinlage • Flat-Gaskets with Steel-inlay	ZUB 10	
	<b>6.03 Clipse und Schellen • Clips and clamps</b>	<b>ZUB 11</b>	
	<b>6.04 Montagematerial • Mounting material</b>	<b>ZUB 13</b>	
	<b>6.05 Werkzeuge • Installations tools</b>	<b>ZUB 14</b>	
	6.05.01 Schneiden • Cutting	ZUB 14	
	6.05.02 Reinigen • Cleaning	ZUB 18	
	6.05.03 Kleben • Bonding	ZUB 18	
	6.05.04 Heizelement-Muffen-Schweißen • Socket welding	ZUB 19	
	6.05.05 Heizelement-Stumpf-Schweißen • Butt welding	ZUB 22	
	6.05.06 Heizwendel-Muffen-Schweißen • Electrofusion-socket welding	ZUB 29	
	6.05.07 Einschweißsättel • Weld-in-saddles	ZUB 34	
	6.05.08 Schälwerkzeuge Stabitec • Peeling tools Stabitec	ZUB 36	
	6.05.09 Reparatursets • Repair sets	ZUB 36	
	6.05.10 Verschiedenes • Miscellaneous	ZUB 37	
	<b>6.06 Armaturen • Valves</b>	<b>ZUB 38</b>	
	<hr/>		
	<b>ANHANG</b>	<b>Anhang</b>	<b>A 1</b>
		▪ A1 Zeichenerklärung • Legend	A 2
▪ A2 Rechtliche Hinweise • Legal notice		A 3	
▪ A3 Verkaufsbedingungen • Conditions of sale		A 4	

# BÄNNINGER – EINE ERFOLGSSTORY

Sie beginnt im Jahre 1987. Die Familien Stamm und Ertl übernahmen die Kunststoff-Sparte von der seit 1909 existierenden Bänninger GmbH und sorgten mit unternehmerischem Geschick für ein dynamisches und gesundes Wachstum. Heute positionieren wir uns als technologischer Vorreiter der Branche mit ca. 200 Mitarbeiterinnen und Mitarbeitern. Geschäftsverbindungen in mehr als 65 Ländern unterstreichen unsere globale strategische Ausrichtung.

## BÄNNINGER – STORY OF SUCCESS

It starts in 1987. The Stamm and Ertl families acquired the plastic division of Bänninger GmbH, which had existed since 1909 and ensured dynamic and healthy growth with their entrepreneurial skill. Today, we are positioning ourselves as a technological forerunner in the industry, with approx. 200 employees. Business relationships in more than 65 countries underline our global strategic orientation.



### WERKSTOFFKOMPETENZ

Makellose Rohstoffe und das Wissen um die Eigenschaften von Rezepturen sind die Basis für erstklassige Produkte. Bänninger verfügt über eine ausgeprägte Werkstoffkompetenz. In unserem eigenen Labor überwachen und prüfen Experten jede einzelne Charge. Sie testen und entwickeln mit dem Ziel, die Materialeigenschaften unserer Produkte permanent zu optimieren.

### MATERIALS COMPLIANCE

First class raw materials and knowledge about the characteristics of recipes are the basis for a high end product. Bänninger has a high degree of materials expertise. In our own laboratory, experts monitor and test every batch. They test and develop with the goal of constantly optimising the material properties of our products.

### ENTWICKLUNGSKOMPETENZ

Innovative, für die jeweilige Anwendung optimierte Produkte, sind die Voraussetzung für „sorgenfreie“ Installationen im Druckbereich. Planer und Anwender in aller Welt wissen bei der Realisierung ihrer Projekte zu schätzen, dass von unseren Entwicklungsteams immer wieder Impulse für noch mehr Sicherheit, Zuverlässigkeit und Nachhaltigkeit kommen.

### DEVELOPMENT EXPERTISE

Innovative products, optimised for the respective application, are the requirement for “carefree” installations in a pressure area. With the realisation of their projects, planners and users all over the world appreciate that impulses for even more safety, reliability and sustainability come from our development teams again and again.

### QUALITÄTSKOMPETENZ

Unser Qualitätskonzept umfasst als permanenter Prozess alle Bereiche des Unternehmens. Es ist im Denken und Handeln der Belegschaft fest verankert. Wir sind zertifiziert nach DIN ISO 9001 sowie DIN ISO 50001. Der hohe Qualitätsstandard erlaubt eine 10-jährige Gewährleistung auf die Produkte mit einer Absicherung von 30 Mio. Euro für ein eventuelles Schadensereignis.

### QUALITY EXPERTISE

As a constant process, our quality concept encompasses all areas of the company. It is firmly anchored in the thinking and actions of the workforce. We are certified according to DIN ISO 9001 and DIN ISO 50001. The high quality standard allows a 10 year warranty on the products, with security of EUR 30 million for a possible loss event.



### FERTIGUNGSKOMPETENZ

Modernste und integrierend gesteuerte Fertigungsanlagen sorgen für gesicherte und effiziente Prozesse. Sie ermöglichen eine beeindruckende Bandbreite an Produkten: Wir können Kleinteile fertigen, aber auch Elemente mit einem Spritzgewicht von bis zu 150 kg und einer Schließkraft von bis zu 3.000 Tonnen. Unsere Extrusionsanlagen fertigen Rohre bis zu einem Durchmesser von 630 mm.

### LOGISTIKKOMPETENZ

Unser Lieferservice ist schnell, individuell und flexibel. Dafür steht Bänninger. Die Voraussetzungen für diesen Standard wurden nochmals verbessert mit der Investition in ein modernes Hochregallager mit einer Aufstellfläche von 7500 m<sup>2</sup>. Es beherbergt die gesamte Produktpalette. Von hier aus erfolgt die Distribution der Produkte direkt oder über unsere Logistikpartner in alle Welt.

### BERATUNGSKOMPETENZ

Unter Kundenorientierung verstehen wir mehr als die Lieferung von guten Produkten. Wir verstehen uns auch als Dienstleister, der Unterstützung für den Planer und technischen Support für den Anwender bietet. Wir sind für Sie da. Mit firmeneigenen kompetenten Experten in Deutschland und in aller Welt.

### PRODUCTION EXPERTISE

State-of-the-art and integrated, controlled production plants ensure secure and efficient processes. They enable an impressive range of products: We can produce small parts, as well as elements with an injection weight of up to 150 kg and clamping force of up to 3,000 tons. Our extrusion plants produce pipes up to a diameter of 630 mm.

### LOGISTICS EXPERTISE

Our delivery service is quick, customised and flexible. Bänninger stands for this. The requirements for this standard have been improved again with the investment in a state-of-the-art high-rack warehouse with an installation space of 7,500 m<sup>2</sup>. It accommodates the entire product range. From here, the distribution of the products takes place directly or through our logistics partners all over the world.

### ADVISORY EXPERTISE

We understand that our customers needs are more than the delivery of good products. We also consider ourselves as a service provider, who provides support for planners and technical support for the users. We are here for you. With the company's own competent experts in Germany and all over the world.





# 1 PVC-U

Als zweitältester Massenkunststoff der Welt hat sich PVC-U in den unterschiedlichsten Anwendungen bewährt. Seit Mitte der 1930er Jahre gibt es Formteile aus PVC-U. Diese zeichnen sich unter anderem durch ihre Trinkwasser-eignung und eine hohe chemische Beständigkeit aus.

## Eigenschaften

- Hohe chemische Beständigkeit
- Hervorragende Verarbeitbarkeit

## Werkstoff

Polyvinylchlorid (PVC) ist ein amorpher thermoplastischer Kunststoff, RAL 7011 Eisengrau

## Verbindungstechnik

- Klebung
- Flanschverbindung



# 1 PVC-U

As the second-oldest mass plastic in the world, PVC-U has been approved and tested in various applications. Since the mid-1930s, fittings made of PVC-U have been used. They convince with very good properties for the usage in drinking water and by their high chemical resistance.

## Properties

- High chemical resistance
- Excellent processing capability

## Material

Polyvinyl Chloride (PVC) is an amorphous thermoplastic polymer, RAL 7011 Iron grey

## Joining technology

- Bonding
- Flange connection.



1.01 Bögen + Winkel • Bends + Elbows **PVC 5**

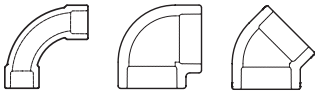

1.02 T-Stücke + Abzweige • Tee's + Branches **PVC 6**

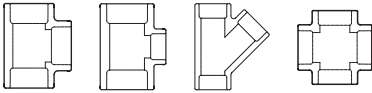

1.03 Reduktionen, Muffen, Kappen  
Reducers, Sockets, Caps **PVC 7**

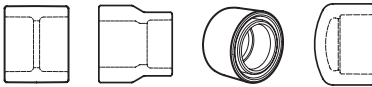

1.04 Übergänge • Transitions **PVC 10**

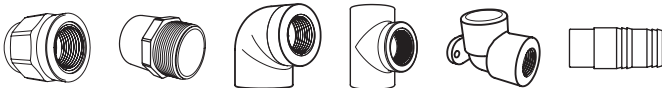

1.05 Verschraubungen • Unions **PVC 13**

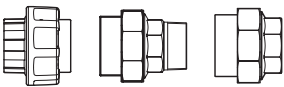

1.06 Flanschverbindung • Flange connection **PVC 18**

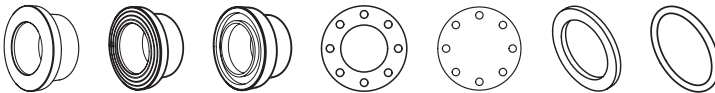

1.07 Formteile mit Kunststoff-Gewinde  
Fittings with plastic-thread **PVC 21**

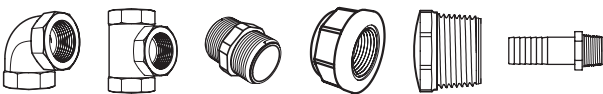

1.08 Kugelhähne • Ball valves **PVC 22**

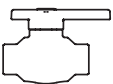

1.09 Ventile • Valves **PVC 24**

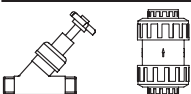

**PVC-U Formteile grau**

gespritzt, für Druckrohrleitungen

**PVC-U Fittings grey**

injection moulded, for pressure pipe systems

**Werkstoff**

PVC-U (Polyvinylchlorid ohne Weichmacher), RAL 7011 Eisengrau. Das Material entspricht den Anforderungen der aktuellen KTW-Leitlinie des Umweltbundesamtes (UBA).

**Geometrische Eigenschaften**

Kleb- und Gewindeformteile in Anlehnung an DIN EN ISO 1452-3. Erfüllt werden zudem die Anforderungen der DIN CERTCO ZP 12.1.10. Toleranzen bei den Z-Maßangaben sind abhängig von der Dimension. Bis d/D 160 = +/- 3 mm. Ab d/D 180 = +/- 10 mm.

**Kleb-Verbindung**

Kleb- und Übergangsformteile sind geeignet zum Verbinden von PVC-U Röhren, deren Außendurchmesser-Toleranzen der DIN 8062 bzw. ISO 11922-1 entsprechen.

**Gewinde-Verbindung**

Die Anschlussgewinde der B-R Übergangsformteile mit Verstärkungsring entsprechen den Normen DIN EN 10226 bzw. ISO 7 [Innengewinde (IG) = zylindrisch, Außengewinde (AG) = keglig].

Die Innengewinde der B-R Gewindeformteile ohne Verstärkungsring sind kegelig entsprechend der ISO 7 ausgeführt.

Das Eindichten von PVC-U Gewindeteilen ist ausschließlich mit PTFE-Band vorzunehmen.

Hanf und Dichtpaste sind ungeeignet und dürfen nicht verwendet werden!

**Betriebsdruck**

Der zulässige Druck ist der jeweiligen Modell-Maßtabelle zu entnehmen. Sofern keine andere Angabe: Richtwert für Klebformteile: PN16 = 16 bar bei 20°C (Wasser). Richtwert für Übergangs-/Gewindefittings und Verschraubungen: PN10 = 10 bar bei 20°C (Wasser).

**Klebstoff**

Für die Herstellung von Klebverbindungen ist die Verwendung eines Klebstoffs auf Basis THF unbedingt erforderlich. Unsere diesbezügliche Verlegeanleitung basiert auf der Verwendung von TANGIT-Klebstoff.

**Kleblängen**

In den Maßtabellen dieses Kataloges sind die Kleblängen nicht gesondert ausgewiesen. Diese sind bei Bedarf generell der nachfolgenden Tabelle zu entnehmen.

**Material**

PVC-U (Polyvinyl Chloride unplasticised), RAL 7011 Iron grey. The material complies with the requirements of the KTW guideline of the German Federal Environmental Agency (UBA).

**Geometric Properties**

Bonding and threaded fittings in accordance to DIN EN ISO 1452-3. Also correspond to DIN CERTCO ZP 12.1.10.

Tolerances of z-sizes depending on the dimension. Up to d/D 160 = +/- 3 mm and from d/D 180 = +/- 10 mm.

**Bonding-connection**

Solvent cement bonding and adaptor fittings are useable for the connection of PVC-U pipes, with outside diameter tolerances in accordance with DIN 8062 respectively ISO 11922-1.

**Threaded-connection**

The threaded connection of B-R adaptor fittings with reinforcing ring comply with the requirements of DIN EN 10226 respectively ISO 7 [female-thread = cylindrical, male-thread = conical].

The female threaded fittings without reinforcing ring are conical due to ISO 7 specifications.

The sealing of PVC-U threads is to be performed exclusively with PTFE tape.

Hemp and sealing paste are unsuitable and may not be used!

**Working pressure**

The admissible pressure has to be used according to the respective measure listing. Unless otherwise stated: Target value for bonding fittings: PN16 = 16 bar at 20°C (water).

Target value for adaptor-/threaded-fittings and unions: PN10 = 10 bar at 20°C (water).

**Solvent cement**

A cement with gap-filling properties on the basis of THF must be used. Our detailed instructions for solvent connections are based on the use of TANGIT solvent cement.

**Length of bonding**

The tables in the catalogue do not contain these lengths. Those are contained only in the below shown table.

**PVC-U Muffen-Einstecktiefe**

PVC-U socket/pipe length to be entered

d [mm]	t [mm]	d [mm]	t [mm]
10	12	75	44
12	12	90	51
16	14	110	61
20	16	140	76
25	19	160	86
32	22	225	119
40	26	250	131
50	31	280	146
63	38	315	164

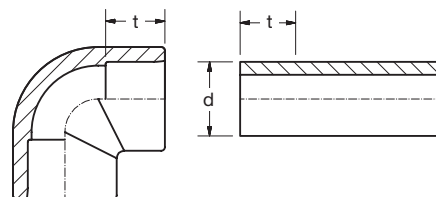

# 1.01 Bögen + Winkel • Bends + Elbows

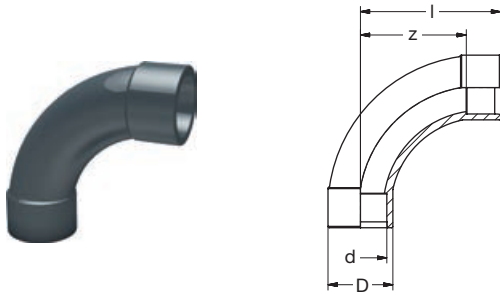

621.00.01 PVC-U Bogen 90° grau  
PVC-U Bend 90° grey

Teil / Item	d [mm]	DN [mm]	D [mm]	l [mm]	z [mm]	PN [bar]	KG	VE1	VE2
1420 0590 12	16	10	23	46	32	16	0,02	10	80
1420 0690 12	20	15	27	56	40	16	0,03	10	80
1420 0790 12	25	20	35	69	50	16	0,05	10	40
1420 0890 12	32	25	40	86	64	16	0,09	5	50
1420 0990 12	40	32	49	106	80	16	0,15	5	30
1420 1090 12	50	40	61	131	100	16	0,27	5	30
1420 1190 12	63	50	76	164	126	16	0,51	2	20
1420 1290 12	75	65	94	190	149	16	1,02	2	8
1420 1390 12	90	80	112	231	180	16	1,79	1	6
1420 1490 12	110	100	137	283	222	16	3,06	1	4
1420 1690 12	140	125	167	355	280	16	5,02	1	2
1420 1790 12	160	150	190	410	319	16	7,41	1	-

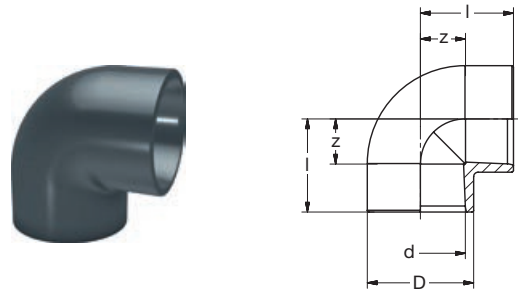

621.10.01 PVC-U Winkel 90° grau  
PVC-U Elbow 90° grey

Teil / Item	d [mm]	DN [mm]	D [mm]	l [mm]	z [mm]	PN [bar]	KG	VE1	VE2
1410 0390 12	10	6	14	18	6	16	0,004	10	300
1410 0490 12	12	8	17	19	7	16	0,005	10	300
1410 0590 12	16	10	23	23	9	16	0,01	10	120
1410 0690 12	20	15	28	27	11	16	0,02	10	120
1410 0790 12	25	20	32	33	14	16	0,03	10	100
1410 0890 12	32	25	40	39	17	16	0,05	10	90
1410 0990 12	40	32	49	49	23	16	0,09	5	50
1410 1090 12	50	40	61	59	27	16	0,16	10	60
1410 1190 12	63	50	75	72	34	16	0,29	5	35
1410 1290 12	75	65	92	82	39	16	0,52	2	24
1410 1390 12	90	80	110	97	46	16	0,70	2	12
1410 1490 12	110	100	132	117	56	16	1,33	2	8
1410 1690 12	140	125	167	147	71	16	2,37	1	4
1410 1790 12	160	150	190	167	81	16	3,73	1	-
1410 2090 12	225	200	256	233	114	10	7,74	1	-
1410 2190 32	250	225	286	317	186	10	9,60	1	-
1410 2290 32	280	250	319	357	210	10	16,4	1	-
1410 2390 32	315	300	360	401	236	10	23,0	1	-

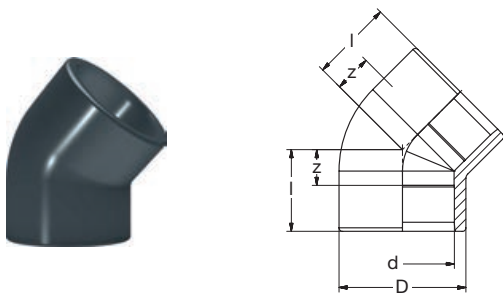

621.15.01 PVC-U Winkel 45° grau  
PVC-U Elbow 45° grey

Teil / Item	d [mm]	DN [mm]	D [mm]	l [mm]	z [mm]	PN [bar]	KG	VE1	VE2
1410 0545 12	16	10	23	23	5	16	0,01	10	150
1410 0645 12	20	15	28	28	5	16	0,02	10	160
1410 0745 12	25	20	34	34	6	16	0,03	10	90
1410 0845 12	32	25	41	41	8	16	0,04	10	50
1410 0945 12	40	32	51	51	10	16	0,08	5	30
1410 1045 12	50	40	61	61	12	16	0,12	5	30
1410 1145 12	63	50	77	77	14	16	0,22	5	40
1410 1245 12	75	65	90	90	17	16	0,32	2	12
1410 1345 12	90	80	110	110	20	16	0,64	2	6
1410 1445 12	110	100	132	132	24	16	0,94	2	10
1410 1645 12	140	125	164	164	30	16	1,59	1	-
1410 1745 12	160	150	188	188	34	16	2,47	1	4
1410 2045 12	225	200	259	259	49	10	5,53	1	-
1410 2145 32	250	225	287	287	58	10	7,70	1	-
1410 2245 32	280	250	320	320	62	10	10,4	1	-
1410 2345 32	315	300	360	360	68	10	13,7	1	-

# 1.02 T-Stücke + Abzweige • Tee's + Branches

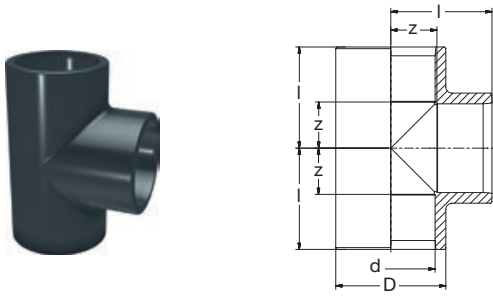

621.20.01 PVC-U T-Stück 90° grau  
PVC-U Tee 90° grey

Teil / Item	d [mm]	DN [mm]	D [mm]	l [mm]	z [mm]	PN [bar]	KG	VE1	VE2
1510 0390 32	10	6	16	19	6	16	0,010	10	140
1510 0490 32	12	8	19	20	7	16	0,010	10	100
1510 0590 12	16	10	23	23	9	16	0,016	10	100
1510 0690 12	20	15	28	27	11	16	0,021	10	100
1510 0790 12	25	20	34	33	14	16	0,036	10	60
1510 0890 12	32	25	41	39	17	16	0,061	10	80
1510 0990 12	40	32	49	47	21	16	0,12	5	40
1510 1090 12	50	40	62	58	27	16	0,21	10	40
1510 1190 12	63	50	77	72	34	16	0,38	5	30
1510 1290 12	75	65	92	84	39	16	0,67	2	16
1510 1390 12	90	80	110	97	46	16	0,96	2	8
1510 1490 12	110	100	132	117	56	16	1,70	2	4
1510 1690 12	140	125	170	149	73	16	3,58	1	-
1510 1790 12	160	150	191	169	83	16	4,64	1	-
1510 2090 12	225	200	256	233	114	10	10,1	1	-
1510 2190 32	250	225	286	261	132	10	13,2	1	-
1510 2290 32	280	250	319	290	144	10	18,1	1	-
1510 2390 32	315	300	360	326	162	10	24,4	1	-

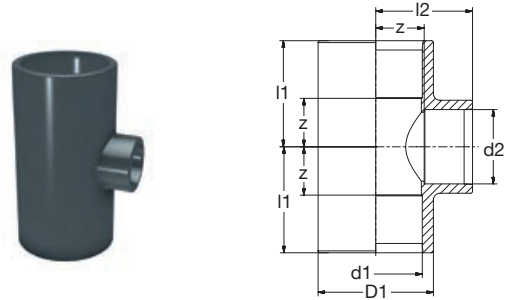

621.20.01 PVC-U T-Stück 90° red grau  
PVC-U Tee 90° red grey

Teil / Item	d1-d2 [mm]	DN1-DN2 [mm]	D1 [mm]	l1 [mm]	l2 [mm]	z [mm]	PN [bar]	KG	VE1	VE2
1520 0706 12	25-20	20-15	33	33	30	14	16	0,046	10	60
1520 0806 22	32-20	25-15	41	39	33	17	16	0,072	10	80
1520 0807 22	32-25	25-20	41	39	36	17	16	0,066	10	80
1520 0906 12	40-20	32-15	50	49	39	24	16	0,11	10	40
1520 0907 12	40-25	32-20	50	49	42	24	16	0,11	10	40
1520 0908 22	40-32	32-25	50	49	45	24	16	0,10	10	40
1520 1006 12	50-20	40-15	62	58	48	27	16	0,20	10	40
1520 1007 12	50-25	40-20	62	58	48	27	16	0,20	10	40
1520 1008 12	50-32	40-25	62	58	48	27	16	0,18	10	40
1520 1009 12	50-40	40-32	62	58	58	27	16	0,25	10	40
1520 1106 12	63-20	50-15	75	71	51	33	16	0,29	5	15
1520 1107 12	63-25	50-20	75	71	53	33	16	0,29	5	15
1520 1108 12	63-32	50-25	75	71	56	33	16	0,29	5	15
1520 1109 12	63-40	50-32	75	71	60	33	16	0,29	5	20
1520 1110 12	63-50	50-40	75	71	65	33	16	0,29	5	15
1520 1210 32	75-50	65-40	92	84	72	39	16	0,51	5	-
1520 1211 32	75-63	65-50	92	84	79	39	16	0,56	5	-
1520 1311 32	90-63	80-50	110	97	93	46	16	0,89	1	-
1520 1312 32	90-75	80-65	110	97	99	46	16	0,89	1	-
1520 1413 32	110-90	100-80	132	117	116	56	16	1,50	1	-
1520 1714 32	160-110	150-100	191	169	142	83	16	4,10	1	-
1520 2017 32	225-160	200-150	256	233	205	114	10	10,0	1	-

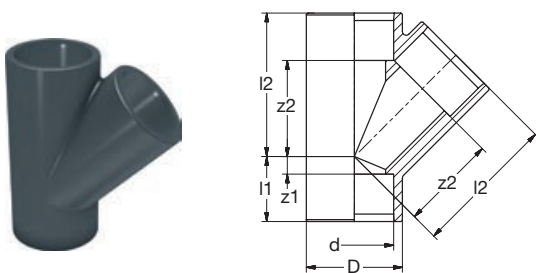

621.25.01 PVC-U Abzweig 45° grau  
PVC-U Branch 45° grey

Teil / Item	d [mm]	DN [mm]	D [mm]	l1 [mm]	l2 [mm]	z1 [mm]	z2 [mm]	PN [bar]	KG	VE1	VE2
1510 0645 32	20	15	28	23	47	5	30	10	0,040	10	-
1510 0745 32	25	20	33	28	56	6	37	10	0,060	10	50
1510 0845 12	32	25	41	29	61	7	39	10	0,086	10	50
1510 0945 12	40	32	51	35	75	9	49	10	0,19	10	30
1510 1045 12	50	40	63	42	92	11	61	10	0,34	5	15
1510 1145 12	63	50	77	52	115	14	77	10	0,51	5	10
1510 1245 12	75	65	90	63	144	19	100	6	0,87	2	10
1510 1345 32	90	80	107	70	175	19	116	6	1,25	1	4
1510 1445 12	110	100	136	88	210	27	148	6	2,81	1	4

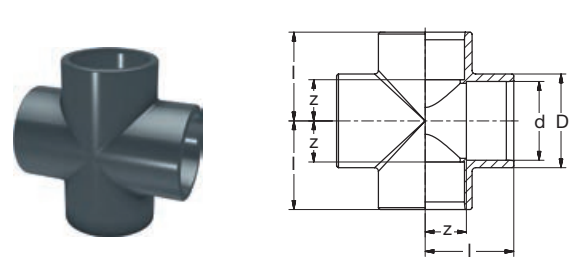

621.30.01 PVC-U Kreuz grau  
PVC-U Cross grey

Teil / Item	d [mm]	DN [mm]	D [mm]	l [mm]	z [mm]	PN [bar]	KG	VE1	VE2
1550 0700 32	25	20	34	32	14	16	0,049	10	40
1550 0800 12	32	25	40	39	17	16	0,068	10	50
1550 0900 12	40	32	51	47	21	16	0,15	10	40
1550 1000 12	50	40	63	57	26	16	0,26	10	30
1550 1100 12	63	50	77	72	34	16	0,46	5	15

# 1.03 Reduktionen, Muffen, Kappen • Reducers, Sockets, Caps

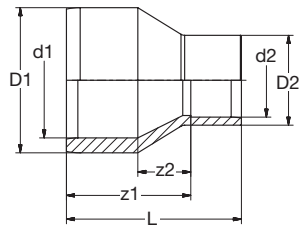

621.91.03 PVC-U Reduktion lang grau  
PVC-U Reducer long grey

Teil / Item	D1-d2 [mm]	d1-d2 [mm]	d1-D2 [mm]	D1-D2 [mm]	DN1 [mm]	DN2 [mm]	D2 [mm]	L [mm]	z1 [mm]	z2 [mm]	PN [bar]	KG	VE1	VE2
1321 0403 32	<b>12-10</b>	8-10			8	6	13	27	15	3	16	0,004	10	-
1321 0503 32	<b>16-10</b>	12-10	12-16	16-16	10	6	16	30	18	6	16	0,010	10	-
1321 0604 32	<b>20-12</b>	16-12	16-16	20-16	15	8	16	33	22	7	16	0,010	10	150
1321 0605 12	<b>20-16</b>				15	10	22	34	20		16	0,009	10	150
1321 0704 32	<b>25-12</b>	20-12	20-16	25-16	20	8	16	38	25	10	16	0,010	10	-
1321 0705 12	<b>25-16</b>				20	10	22	39	25		16	0,011	10	200
1321 0706 12	<b>25-20</b>				20	15	26	40	24		16	0,012	10	120
1321 0805 12	<b>32-16</b>	25-16			25	10	22	44	30	11	16	0,016	10	90
1321 0806 12	<b>32-20</b>	25-20			25	15	26	46	30	11	16	0,017	10	90
1321 0807 12	<b>32-25</b>				25	20	31	48	30		16	0,021	10	90
1321 0905 12	<b>40-16</b>	32-16			32	10	22	50	36	14	16	0,025	10	60
1321 0906 12	<b>40-20</b>	32-20			32	15	26	52	36	14	16	0,029	10	60
1321 0907 12	<b>40-25</b>	32-25			32	20	31	55	36	14	16	0,029	10	60
1321 0908 12	<b>40-32</b>				32	25	39	59	37	14	16	0,035	10	60
1321 1006 12	<b>50-20</b>	40-20			40	15	26	60	44	18	16	0,052	10	50
1321 1007 12	<b>50-25</b>	40-25			40	20	32	62	44	18	16	0,052	10	50
1321 1008 12	<b>50-32</b>	40-32			40	25	39	66	44	18	16	0,060	10	40
1321 1009 12	<b>50-40</b>				40	32	48	70	44		16	0,082	10	30
1321 1107 12	<b>63-25</b>	50-25			50	20	32	73	54	23	16	0,085	5	40
1321 1108 12	<b>63-32</b>	50-32			50	25	39	76	54	23	16	0,092	5	40
1321 1109 12	<b>63-40</b>	50-40			50	32	48	80	54	23	16	0,099	5	40
1321 1110 12	<b>63-50</b>				50	40	60	85	54		16	0,10	5	40
1321 1208 32	<b>75-32</b>	63-32	63-40	75-40	65	25	40	85	62	25	16	0,14	5	-
1321 1209 32	<b>75-40</b>	63-40	63-50	75-50	65	32	50	88	62	24	16	0,15	5	-
1321 1210 32	<b>75-50</b>	63-50	63-63	75-63	65	40	63	93	62	24	16	0,17	5	-
1321 1211 32	<b>75-63</b>	63-63			65	50	75	101	62	25	16	0,21	5	-
1321 1309 32	<b>90-40</b>	75-40	75-50	75-50	80	32	50	101	74	31	16	0,23	5	-
1321 1310 32	<b>90-50</b>	75-50	75-63	75-63	80	40	63	105	74	30	16	0,24	5	-
1321 1311 32	<b>90-63</b>	75-63	75-75	75-75	80	50	75	113	74	31	16	0,28	5	-
1321 1312 32	<b>90-75</b>	75-75			80	65	90	119	74	31	16	0,34	5	-
1321 1614 32	<b>140-110</b>				125	100	126	172	110		16	0,83	1	-

D1-d2 Maße = Rohr-Muffe Sizes = Pipe-Socket  
d1-d2 Maße = Muffe-Muffe Sizes = Socket-Socket  
d1-D2 Maße = Muffe-Rohr Sizes = Socket-Pipe  
D1-D2 Maße = Rohr-Rohr Sizes = Pipe-Pipe

# 1.03 Reduktionen, Muffen, Kappen • Reducers, Sockets, Caps

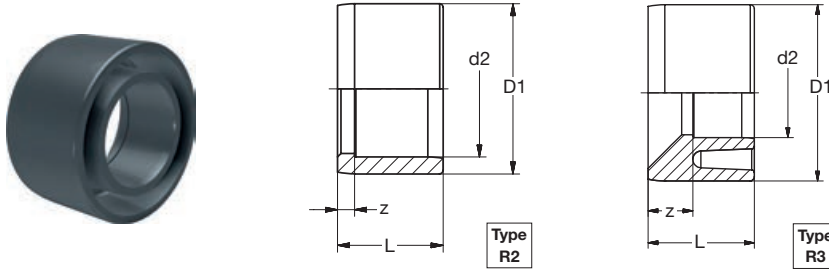

621.90.03 PVC-U Reduktion kurz grau  
PVC-U Reducer short grey

Teil / Item	D1-d2 [mm]	DN1-DN2 [mm]	Type		L [mm]	z [mm]	PN [bar]	KG	VE1	VE2
			R2	R3						
1322 0504 12	16-12	10-8	•		14	2	16	0,002	10	1000
1322 0605 12	20-16	15-10	•		16	2	16	0,003	10	500
1322 0705 12	25-16	20-10	•		19	5	16	0,008	10	300
1322 0706 12	25-20	20-15	•		19	3	16	0,005	10	200
1322 0805 12	32-16	25-10	•		22	8	16	0,014	10	150
1322 0806 12	32-20	25-15	•		22	6	16	0,015	10	140
1322 0807 12	32-25	25-20	•		22	3	16	0,009	10	140
1322 0905 12	40-16	32-10	•		26	12	16	0,021	10	120
1322 0906 12	40-20	32-15	•		26	10	16	0,023	10	120
1322 0907 12	40-25	32-20	•		26	7	16	0,021	10	120
1322 0908 12	40-32	32-25	•		26	4	16	0,016	10	120
1322 1006 12	50-20	40-15	•		31	15	16	0,040	10	80
1322 1007 12	50-25	40-20	•		31	12	16	0,041	10	80
1322 1008 12	50-32	40-25	•		31	9	16	0,039	10	80
1322 1009 12	50-40	40-32	•		31	5	16	0,029	10	80
1322 1107 12	63-25	50-20	•		38	19	16	0,083	10	70
1322 1108 12	63-32	50-25	•		38	16	16	0,077	10	70
1322 1109 12	63-40	50-32	•		38	12	16	0,073	10	70
1322 1110 12	63-50	50-40	•		38	7	16	0,062	10	70
1322 1208 12	75-32	65-25	•		44	21	16	0,11	10	60
1322 1209 12	75-40	65-32	•		44	17	16	0,11	10	60
1322 1210 12	75-50	65-40	•		44	13	16	0,11	10	60
1322 1211 12	75-63	65-50	•		44	7	16	0,085	10	60
1322 1309 12	90-40	80-32	•		51	25	16	0,18	2	40
1322 1310 12	90-50	80-40	•		51	20	16	0,18	2	40
1322 1311 12	90-63	80-50	•		51	13	16	0,18	2	40
1322 1312 12	90-75	80-65	•		51	8	16	0,14	2	40
1322 1410 12	110-50	100-40	•		61	31	16	0,30	2	20
1322 1411 12	110-63	100-50	•		61	24	16	0,31	2	20
1322 1412 12	110-75	100-65	•		61	17	16	0,31	2	18
1322 1413 12	110-90	100-80	•		61	10	16	0,26	2	18
1322 1514 32	125-110	100-100	•		69	8	16	0,26	2	18
1322 1612 12	140-75	125-65	•		76	32	16	0,62	2	20
1322 1613 12	140-90	125-80	•		76	25	16	0,62	2	20
1322 1614 12	140-110	125-100	•		76	15	16	0,60	2	20
1322 1615 32	140-125	125-100	•		76	7	16	0,33	2	20
1322 1713 12	160-90	150-80	•		86	34	16	0,84	2	6
1322 1714 12	160-110	150-100	•		86	24	16	0,86	2	6
1322 1716 12	160-140	150-125	•		86	10	16	0,57	2	6
1322 1917 32	200-160	180-150	•		106	20	10	1,67	1	3
1322 2017 12	225-160	200-150	•		119	33	10	2,19	1	3
1322 2019 32	225-200	200-180	•		119	33	10	1,70	1	-
1322 2120 32	250-225	225-200	•		132	12	10	4,44	1	-
1322 2220 32	280-225	250-200	•		146	27	10	4,70	1	-
1322 2221 32	280-250	250-225	•		146	15	10	5,68	1	-
1322 2320 32	315-225	300-200	•		163	45	10	6,52	1	-
1322 2321 32	315-250	300-225	•		164	33	10	6,49	1	-
1322 2322 32	315-280	300-250	•		163	17	10	6,70	1	-

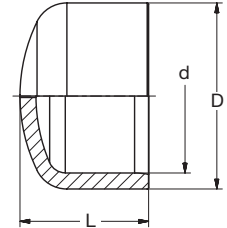
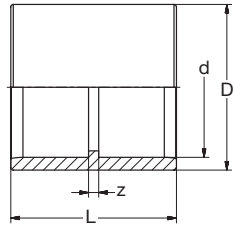

621.91.01 PVC-U Muffe grau  
PVC-U Socket grey

Teil / Item	d [mm]	DN [mm]	D [mm]	L [mm]	z [mm]	PN [bar]	KG	VE1	VE2
1310 0200 32	8	5	14	28	3	16	0,004	10	-
1310 0300 32	10	6	16	28	3	16	0,010	10	-
1310 0400 32	12	8	19	28	3	16	0,010	10	-
1310 0500 12	16	10	22	32	3	16	0,008	10	200
1310 0600 12	20	15	26	34	3	16	0,011	10	200
1310 0700 12	25	20	31	40	3	16	0,015	10	140
1310 0800 12	32	25	39	47	3	16	0,022	10	70
1310 0900 12	40	32	48	56	4	16	0,037	10	80
1310 1000 12	50	40	60	66	4	16	0,070	10	60
1310 1100 12	63	50	75	80	4	16	0,14	5	30
1310 1200 12	75	65	89	96	8	16	0,54	2	20
1310 1300 12	90	80	107	108	4	16	0,38	2	12
1310 1400 12	110	100	130	130	8	16	0,63	2	18
1310 1600 12	140	125	163	160	8	16	1,21	1	8
1310 1700 12	160	150	186	182	8	16	1,81	1	2
1310 2000 12	225	200	260	248	12	10	3,41	1	-
1310 2100 32	250	225	287	282	14	10	5,70	1	-
1310 2200 32	280	250	320	314	18	10	7,30	1	-
1310 2300 32	315	300	355	348	14	10	9,20	1	-

621.96.01 PVC-U Kappe grau  
PVC-U Cap grey

Teil / Item	d [mm]	DN [mm]	D [mm]	L [mm]	PN [bar]	KG	VE1	VE2
1340 0400 32	12	8	21	16	16	0,008	10	-
1340 0500 12	16	10	23	20	16	0,006	10	250
1340 0600 12	20	15	28	23	16	0,009	10	200
1340 0700 12	25	20	34	26	16	0,014	10	120
1340 0800 12	32	25	41	32	16	0,023	10	120
1340 0900 12	40	32	52	39	16	0,046	10	80
1340 1000 12	50	40	63	48	16	0,077	10	70
1340 1100 12	63	50	77	56	16	0,12	5	120
1340 1200 12	75	65	90	66	10	0,19	2	16
1340 1300 12	90	80	110	77	10	0,34	2	16
1340 1400 12	110	100	133	92	6	0,62	2	8
1340 1600 12	140	125	161	121	6	0,94	1	5
1340 1700 12	160	150	185	136	4	1,48	1	8
1340 2000 12	225	200	260	174	4	3,44	1	2

# 1.04 Übergänge • Transitions

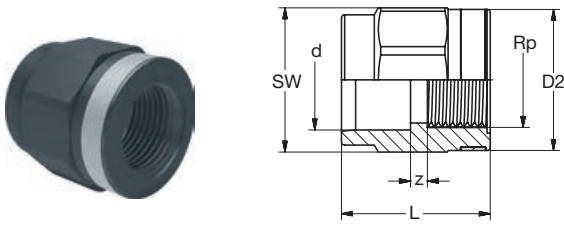

621.91.02 PVC-U Ü-Muffe IG-zyl grau  
PVC-U Transition-Socket female-thread-cyl grey

Teil / Item	d x Rp [mm x Inch]	DN [mm]	D2 [mm]	L [mm]	z [mm]	SW [mm]	P [bar]	KG	VE1	VE2
161M 0441 32	12 x 1/4	8	20	27	4	22	10	0,010	10	-
161M 0542 12	16 x 3/8	10	25	30	5	27	10	0,016	10	150
161M 0643 12	20 x 1/2	15	30	36	5	30	10	0,025	10	150
161M 0745 12	25 x 3/4	20	35	40	5	36	10	0,032	10	100
161M 0846 12	32 x 1	25	45	47	5	46	10	0,056	10	60
161M 0947 12	40 x 1 1/4	32	55	52	5	55	10	0,090	10	80
161M 1048 12	50 x 1 1/2	40	65	60	7	65	10	0,15	10	60
161M 1150 12	63 x 2	50	75	72	7	80	10	0,22	5	75
161M 1253 22	75 x 2 1/2	65	89	92	18	90	10	0,31	5	-
161M 1355 22	90 x 3	80	107	107	23	108	10	0,52	5	-
161M 1457 32	110 x 4	100	130	128	28	131	10	0,74	5	-

Anschluss an Metall- oder Kunststoffgewinde.  
Connection to metal or plastic thread.

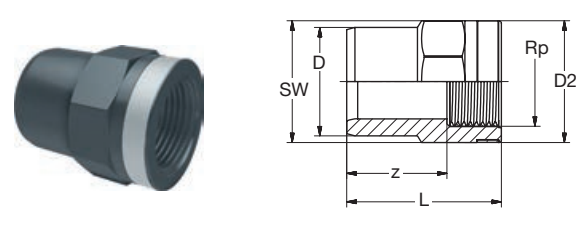

621.91.04 PVC-U Ü-Reduktion IG-zyl grau  
PVC-U Transition-Reducer female-thread-cyl grey

Teil / Item	D x Rp [mm x Inch]	DN [mm]	D2 [mm]	L [mm]	z [mm]	SW [mm]	P [bar]	KG	VE1	VE2
163M 0441 32	12 x 1/4	8	20	27	17	22	10	0,010	10	-
163M 0642 12	20 x 3/8	15	25	35	24	27	10	0,016	10	150
163M 0743 12	25 x 1/2	20	30	42	27	32	10	0,025	10	150
163M 0845 12	32 x 3/4	25	35	48	32	36	10	0,037	10	80
163M 0946 12	40 x 1	32	45	56	36	46	10	0,069	10	50
163M 1047 12	50 x 1 1/4	40	55	66	46	55	10	0,12	10	60
163M 1148 12	63 x 1 1/2	50	65	77	55	65	5	0,18	5	40

Anschluss an Metall- oder Kunststoffgewinde.  
Connection to metal or plastic thread.

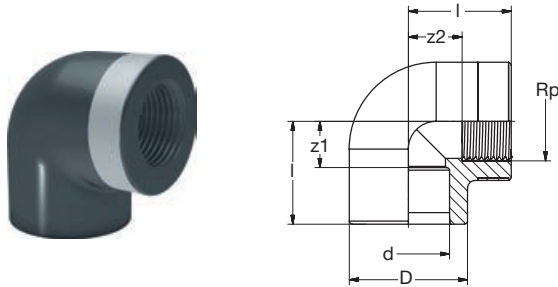

621.10.02 PVC-U Ü-Winkel 90° IG-zyl grau  
PVC-U Transition-Elbow 90° female-thread-cyl grey

Teil / Item	d x Rp [mm x Inch]	DN [mm]	D [mm]	l [mm]	z1 [mm]	z2 [mm]	P [bar]	KG	VE1	VE2
162M 0441 32	12 x 1/4	8	20	19	7	8	10	0,010	10	-
162M 0542 32	16 x 3/8	10	25	23	9	12	10	0,020	10	-
162M 0643 12	20 x 1/2	15	30	28	12	14	10	0,033	10	120
162M 0745 12	25 x 3/4	20	36	34	14	17	10	0,050	10	60
162M 0846 12	32 x 1	25	47	40	17	22	10	0,096	10	30
162M 0947 12	40 x 1 1/4	32	55	49	22	28	10	0,17	10	90
162M 1048 12	50 x 1 1/2	40	65	59	27	38	10	0,27	10	20
162M 1150 32	63 x 2	50	75	71	33	46	10	0,29	5	-

Anschluss an Metall- oder Kunststoffgewinde.  
Connection to metal or plastic thread.

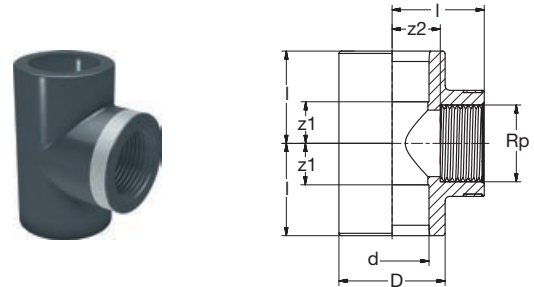

621.20.02 PVC-U Ü-T-Stück 90° IG-zyl grau  
PVC-U Transition-Tee 90° female-thread-cyl grey

Teil / Item	d x Rp [mm x Inch]	DN [mm]	D [mm]	l [mm]	z1 [mm]	z2 [mm]	P [bar]	KG	VE1	VE2
164M 0441 32	12 x 1/4	8	20	19	7	8	10	0,020	10	-
164M 0542 32	16 x 3/8	10	25	23	9	12	10	0,030	10	-
164M 0643 12	20 x 1/2	15	30	28	12	14	10	0,040	10	80
164M 0745 12	25 x 3/4	20	36	33	14	17	10	0,062	10	50
164M 0846 12	32 x 1	25	47	40	18	22	10	0,13	10	20
164M 0947 12	40 x 1 1/4	32	55	49	22	28	10	0,21	10	30
164M 1048 12	50 x 1 1/2	40	65	59	27	38	10	0,31	10	20
164M 1150 32	63 x 2	50	75	71	33	46	10	0,41	5	-

Anschluss an Metall- oder Kunststoffgewinde.  
Connection to metal or plastic thread.

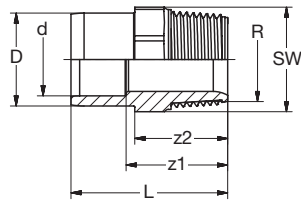

621.91.17 PVC-U Ü-Reduktion/Muffe **AG-keg** grau  
PVC-U Transition-Reducer/Socket **male-thread-con** grey

Teil / Item	D / d x R [mm x Inch]	DN / DN [mm]	L [mm]	z1 [mm]	z2 [mm]	SW [mm]	P [bar]	KG	VE1	VE2
1610 0572 12	16 / 12 x 3/8	10 / 8	35	23	21	22	10	0,010	10	150
1610 0672 12	20 / 16 x 3/8	15 / 10	37	23	21	27	10	0,010	10	150
1610 0673 12	20 / 16 x 1/2	15 / 10	42	28	26	24	10	0,012	10	160
1610 0773 12	25 / 20 x 1/2	20 / 15	45	29	26	30	10	0,017	10	130
1610 0775 12	25 / 20 x 3/4	20 / 15	47	31	28	30	10	0,019	10	100
1610 0875 12	32 / 25 x 3/4	25 / 20	50	31	28	36	10	0,028	10	100
1610 0876 12	32 / 25 x 1	25 / 20	54	35	32	36	10	0,031	10	50
1610 0976 12	40 / 32 x 1	32 / 25	58	36	32	46	10	0,044	10	60
1610 0977 12	40 / 32 x 1 1/4	32 / 25	60	38	34	46	10	0,049	10	100
1610 1077 12	50 / 40 x 1 1/4	40 / 32	65	39	34	55	10	0,069	10	60
1610 1078 12	50 / 40 x 1 1/2	40 / 32	65	41	35	55	10	0,075	10	70
1610 1178 12	63 / 50 x 1 1/2	50 / 40	73	42	35	65	10	0,12	5	60
1610 1180 12	63 / 50 x 2	50 / 40	78	47	40	65	10	0,14	5	60
1610 1280 12	75 / 63 x 2	65 / 50	84	46	40	80	10	0,17	5	60

Anschluss an Kunststoffgewinde.  
Connection to plastic thread.

621.91.17 PVC-U Ü-Reduktion/Muffe **AG-zyl** grau  
PVC-U Transition-Reducer/Socket **male-thread-cyl** grey

Teil / Item	D / d x R [mm x Inch]	DN / DN [mm]	L [mm]	z1 [mm]	z2 [mm]	SW [mm]	P [bar]	KG	VE1	VE2
1610 1383 32	90 / 75 x 2 1/2	80 / 65	99	55	48	95	10	0,31	2	32
1610 1485 32	110 / 90 x 3	100 / 80	113	62	52	115	10	0,44	2	18
1610 1587 32	125 / 110 x 4	100 / 100	120	59	54	130	10	0,71	1	12

Anschluss an Kunststoffgewinde.  
Connection to plastic thread.

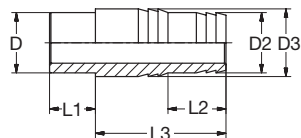

621.96.04 PVC-U Druckschlauchtülle grau  
PVC-U Hose nozzle grey

Teil / Item	D [mm]	D2 [mm]	D3 [mm]	L1 [mm]	L2 [mm]	L3 [mm]	P [bar]	KG	VE1	VE2
1380 0300 12	10	10	-	12	-	39	10	0,002	10	3000
1380 0400 12	12	12	-	12	-	39	10	0,004	10	1800
1380 0500 32	16	16	18	14	18	40	10	0,010	10	1000
1380 0600 32	20	20	22	16	20	44	10	0,015	10	600
1380 0700 32	25	25	28	19	24	54	10	0,020	10	450
1380 0800 32	32	31	34	22	28	63	10	0,044	10	250
1380 0900 32	40	40	43	26	32	72	10	0,060	10	200
1380 1000 32	50	50	53	31	35	80	10	0,11	10	120
1380 1100 32	63	60	66	38	40	90	10	0,15	10	60

# 1.04 Übergänge • Transitions

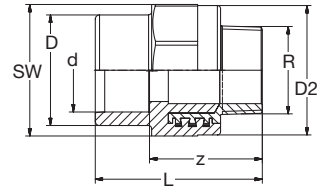
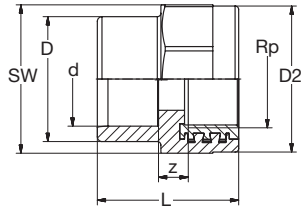

620.91.02 PVC-U-RG Ü-Muffe IG-zyl grau  
PVC-U-Bronze Transition-Socket female-thread-cyl grey

Teil / Item	d x Rp [mm x Inch]	DN [mm]	D [mm]	D2 [mm]	L [mm]	z [mm]	SW [mm]	P [bar]	KG	VE1	VE2
1R10 0643 12	20 x 1/2	15	29	35	40	10	36	16	0,076	10	100
1R10 0745 12	25 x 3/4	20	34	43	42	8	44	16	0,12	10	50
1R10 0846 12	32 x 1	25	43	50	52	12	51	16	0,18	10	50
1R10 0947 12	40 x 1 1/4	32	52	62	59	13	63	16	0,26	10	36
1R10 1048 12	50 x 1 1/2	40	64	69	65	14	70	16	0,30	2	24
1R10 1150 12	63 x 2	50	79	84	78	19	85	16	0,57	2	12

620.91.07 PVC-U-RG Ü-Muffe AG-keg grau  
PVC-U-Bronze Transition-Socket male-thread-con grey

Teil / Item	d x Rp [mm x Inch]	DN [mm]	D [mm]	D2 [mm]	L [mm]	z [mm]	SW [mm]	P [bar]	KG	VE1	VE2
1R10 0673 12	20 x 1/2	15	29	35	55	39	36	16	0,10	10	90
1R10 0775 12	25 x 3/4	20	34	43	58	39	44	16	0,14	10	50
1R10 0876 12	32 x 1	25	43	50	70	48	51	16	0,23	10	40
1R10 0977 12	40 x 1 1/4	32	52	62	79	53	63	16	0,36	2	24
1R10 1078 12	50 x 1 1/2	40	64	69	85	54	70	16	0,42	2	16
1R10 1180 12	63 x 2	50	79	84	103	65	85	16	0,73	2	12

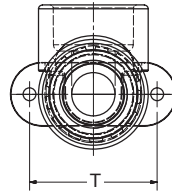
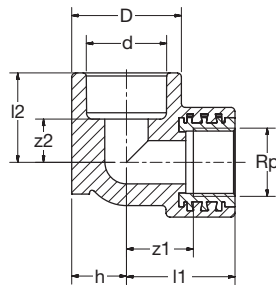

620.100 PVC-U-RG Ü-Winkel 90 IG-zyl Wandbefestigung grau  
PVC-U-Bronze Transition-Elbow female-thread-cyl wall-mount grey

Teil / Item	d x Rp [mm x Inch]	DN [mm]	D [mm]	L1 [mm]	L2 [mm]	h [mm]	T* [mm]	z1 [mm]	z2 [mm]	P [bar]	KG	VE1	VE2
1R30 0643 12	20 x 1/2	15	29	35	27	15	40	21	11	16	0,12	1	50
1R30 0745 12	25 x 3/4	20	43	43	35	22	50	28	19	16	0,18	1	30

\* Abstand der Befestigungslöcher • Distance of mounting holes.

# 1.05 Verschraubungen • Unions

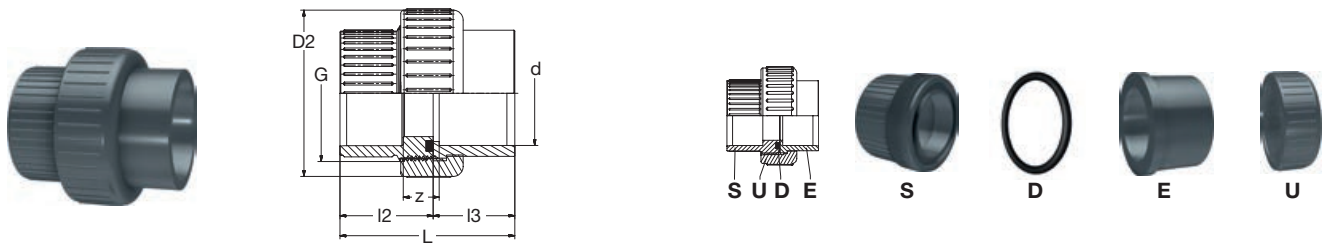

621.51.01 PVC-U Verschraubung Runddichtring-EPDM grau  
PVC-U Union O-Ring-gasket-EPDM grey

Teil / Item	d [mm]	DN [mm]	G [Inch]	D2 [mm]	L [mm]	l2 [mm]	l3 [mm]	z [mm]	P [bar]	KG	VE1	VE2
1350 0300 32	10	6	5/8	31	37	15	22	13	10	0,020	10	-
1350 0400 32	12	8	5/8	31	37	15	22	13	10	0,020	10	-
1350 0500 12	16	10	3/4	35	41	17	24	13	10	0,024	10	140
1350 0600 12	20	15	1	43	46	19	26	13	10	0,039	10	80
1350 0700 12	25	20	1 1/4	53	52	22	30	13	10	0,064	10	90
1350 0800 12	32	25	1 1/2	60	57	25	32	13	10	0,085	10	60
1350 0900 12	40	32	2	74	68	30	38	15	10	0,15	10	40
1350 1000 12	50	40	2 1/4	83	79	35	44	17	10	0,20	10	60
1350 1100 12	63	50	2 3/4	103	97	41	55	21	10	0,35	2	30
1350 1200 12	75	65	3 1/2	122	108	47	61	20	10	0,58	2	18
1350 1300 12	90	80	4	139	124	56	68	22	6	0,75	1	18
1350 1400 12	110	100	5	164	138	66	72	16	6	1,15	1	8

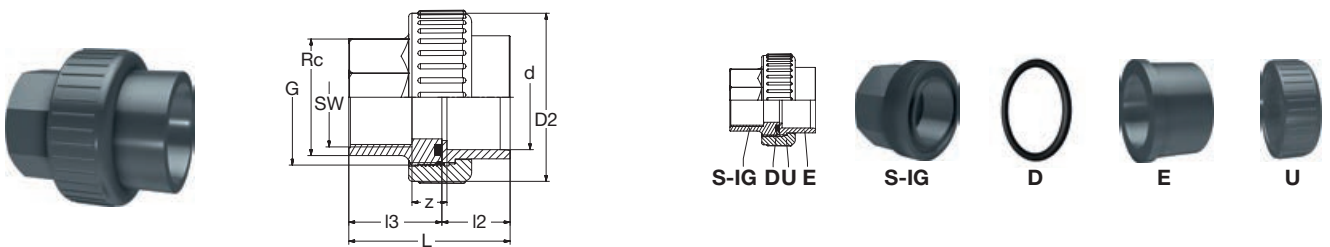

621.50.32 PVC-U Ü-Verschraubung IG-keg Runddichtring-EPDM grau  
PVC-U Transition-Union female-thread-con O-Ring-gasket-EPDM grey

Teil / Item	d x Rc [mm x Inch]	DN [mm]	G [Inch]	D2 [mm]	L [mm]	l2 [mm]	l3 [mm]	z [mm]	SW [mm]	P [bar]	KG	VE1	VE2
1650 0542 12	16 x 3/8	10	3/4	35	41	17	24	16	22	10	0,024	1	-
1650 0643 12	20 x 1/2	15	1	43	45	19	26	16	27	10	0,039	1	-
1650 0745 12	25 x 3/4	20	1 1/4	53	51	22	29	16	36	10	0,064	1	-
1650 0846 12	32 x 1	25	1 1/2	60	57	25	32	16	41	10	0,085	1	-
1650 0947 12	40 x 1 1/4	32	2	74	67	29	38	20	50	10	0,15	1	-
1650 1048 12	50 x 1 1/2	40	2 1/4	83	79	34	45	27	60	10	0,20	1	-
1650 1150 12	63 x 2	50	2 3/4	103	97	41	56	34	70	10	0,35	1	-

# 1.05 Verschraubungen • Unions

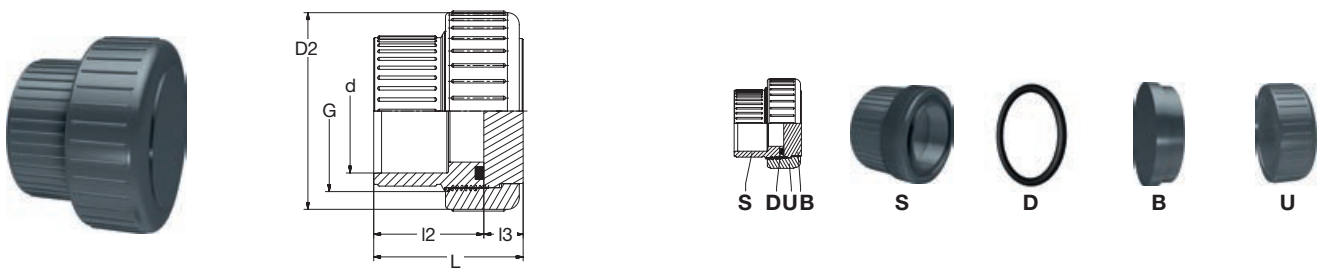

621.51.00 PVC-U Verschraubung mit Blinddeckel Runddichtring-EPDM grau  
 PVC-U Union with blind-cover O-Ring-gasket-EPDM grey

Teil / Item	d [mm]	DN [mm]	D [mm]	G [Inch]	L [mm]	l1 [mm]	l2 [mm]	P [bar]	KG	VE1	VE2
135B 0690 12	20	15	43	1	38	12	26	10	0,038	1	-
135B 0790 12	25	20	53	1 1/4	45	15	30	10	0,068	1	-
135B 0890 12	32	25	60	1 1/2	47	15	32	10	0,097	1	-
135B 0990 12	40	32	74	2	55	17	38	10	0,16	1	-
135B 1090 12	50	40	83	2 1/4	61	17	44	10	0,22	1	-
135B 1190 12	63	50	103	2 1/2	75	20	55	10	0,39	1	-

## Einzelteile Verschraubungen • Spare parts Unions

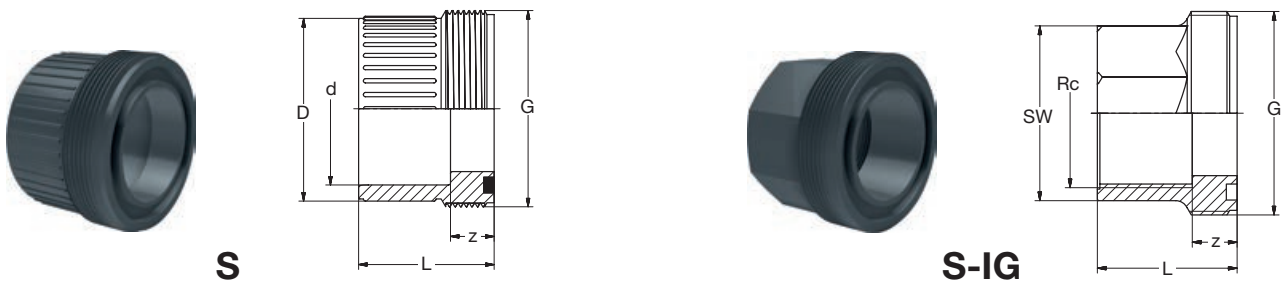

621.64.01 PVC-U Verschraubung Schraubteil grau  
 PVC-U Union Screw-part grey

Teil / Item	d [mm]	DN [mm]	G [Inch]	D [mm]	L [mm]	z [mm]	P [bar]	KG	VE1	VE2
1350 03S0 32	10	6	5/8	20	23	10	10	0,010	10	-
1350 04S0 32	12	8	5/8	20	23	10	10	0,010	10	-
1350 05S0 12	16	10	3/4	23	24	10	10	0,008	50	1500
1350 06S0 12	20	15	1	28	26	10	10	0,013	50	1000
1350 07S0 12	25	20	1 1/4	33	29	10	10	0,020	50	650
1350 08S0 12	32	25	1 1/2	40	31	10	10	0,027	50	400
1350 09S0 12	40	32	2	50	38	12	10	0,032	25	200
1350 10S0 12	50	40	2 1/4	61	44	14	10	0,062	1	180
1350 11S0 12	63	50	2 3/4	76	55	18	10	0,12	1	80
1350 12S0 12	75	65	3 1/2	96	61	17	10	0,22	1	50
1350 13S0 12	90	80	4	109	68	17	6	0,27	1	40
1350 14S0 12	110	100	5	133	72	11	6	0,41	1	30

621.63.16 PVC-U Verschraubung Schraubteil-IG-zyl grau  
 PVC-U Union Screw-part female-thread-cyl grey

Teil / Item	Rc [Inch]	G [Inch]	L [mm]	z [mm]	SW [mm]	P [bar]	KG	VE1	VE2
1650 42S0 12	3/8	3/4	24	10	22	10	0,009	1	250
1650 43S0 12	1/2	1	26	10	27	10	0,013	1	1000
1650 45S0 12	3/4	1 1/4	29	10	36	10	0,026	1	600
1650 46S0 12	1	1 1/2	32	10	41	10	0,031	1	200
1650 47S0 12	1 1/4	2	38	10	50	10	0,059	1	200
1650 48S0 12	1 1/2	2 1/4	45	10	60	10	0,089	1	150
1650 50S0 12	2	2 3/4	56	12	70	10	0,15	1	90

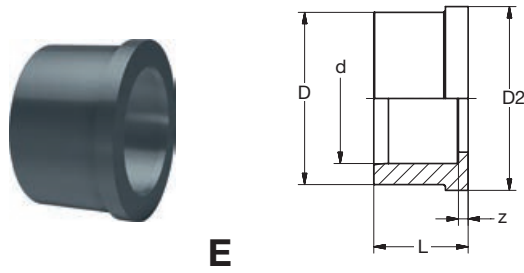

**E**

621.60.01 PVC-U Verschraubung Einlegeteil grau  
PVC-U Union Insert-part grey

Teil / Item	d [mm]	DN [mm]	D [mm]	D2 [mm]	L [mm]	z [mm]	P [bar]	KG	VE1	VE2
1350 03E0 32	10	6	19,0	20,0	15	3	10	0,004	10	-
1350 04E0 32	12	8	19,0	20,0	15	3	10	0,004	10	-
1350 05E0 12	16	10	22,0	24,0	17	3	10	0,005	50	1200
1350 06E0 12	20	15	27,5	30,1	19	3	10	0,008	50	700
1350 07E0 12	25	20	36,0	38,8	22	3	10	0,015	50	400
1350 08E0 12	32	25	41,5	44,7	25	3	10	0,020	50	500
1350 09E0 12	40	32	53,0	56,5	29	3	10	0,032	25	300
1350 10E0 12	50	40	59,0	62,6	34	3	10	0,040	1	250
1350 11E0 12	63	50	74,0	78,4	41	3	10	0,073	1	130
1350 12E0 12	75	65	92,5	97,2	47	3	10	0,16	1	70
1350 13E0 12	90	80	105,0	110,0	56	5	6	0,19	1	50
1350 14E0 12	110	100	129,0	134,4	66	5	6	0,34	1	30

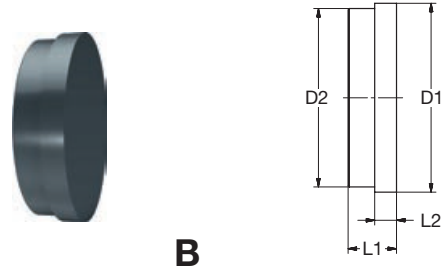

**B**

621.60.00 PVC-U Verschraubung Blinddeckel grau  
PVC-U Union Blind-cover grey

Teil / Item	d [mm]	DN [mm]	D1 [mm]	D2 [mm]	L1 [mm]	L2 [mm]	P [bar]	KG	VE1	VE2
1350 06B0 02	20	15	30,0	27,5	12	5,5	10	0,010	1	-
1350 07B0 02	25	20	39,0	36,0	15	7,0	10	0,017	1	-
1350 08B0 02	32	25	44,3	41,2	15	6,8	10	0,025	1	-
1350 09B0 02	40	32	56,0	53,0	17	8,0	10	0,043	1	-
1350 10B0 02	50	40	62,5	59,0	17	7,0	10	0,062	1	-
1350 11B0 02	63	50	78,0	73,7	20	9,0	10	0,11	1	-

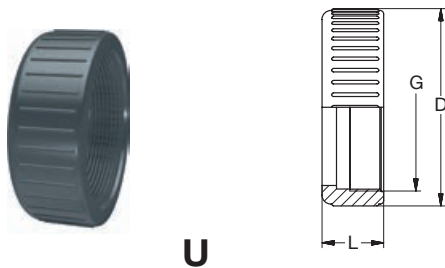

**U**

621.69.00 PVC-U Verschraubung Überwurfmutter IG-zyl grau  
PVC-U Union Nut female-thread-cyl grey

Teil / Item	d [mm]	DN [mm]	G [Inch]	D [mm]	L [mm]	P [bar]	KG	VE1	VE2
1350 03U0 32	10	6	5/8	29	19	10	0,010	1	-
1350 03U0 32	12	8	5/8	29	19	10	0,010	1	-
1350 05U0 12	16	10	3/4	33	22	10	0,011	50	1000
1350 06U0 12	20	15	1	41	23	10	0,017	50	750
1350 07U0 12	25	20	1 1/4	51	25	10	0,028	50	400
1350 08U0 12	32	25	1 1/2	58	27	10	0,037	25	300
1350 09U0 12	40	32	2	72	30	10	0,061	1	200
1350 10U0 12	50	40	2 1/4	80	34	10	0,087	1	160
1350 11U0 12	63	50	2 3/4	100	38	10	0,15	1	80
1350 12U0 12	75	65	3 1/2	118	43	10	0,21	1	50
1350 13U0 12	90	80	4	134	45	6	0,29	1	40
1350 14U0 12	110	100	5	159	51	6	0,40	1	25

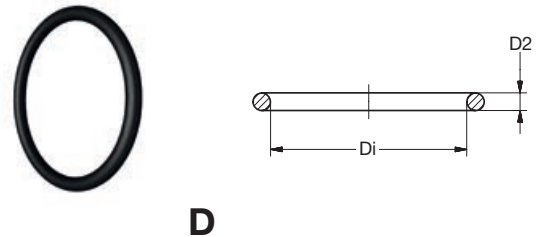

**D**

Runddichtring für Verschraubungen schwarz  
O-Ring-gasket for unions black

Teil / Item	Teil / Item	G [Inch]	Di [mm]	D2 [mm]	KG	VE1	VE2
EPDM	FKM (FPM)						
Wasser/water							
9205 44R1 35	9205 44R3 35	5/8	12,37	2,62	0,001	10	-
9205 45R1 35	9205 45R3 35	3/4	15,55	2,62	0,001	10	-
9205 46R1 35	9205 46R3 35	1	20,22	3,53	0,001	10	-
9201 07R1 35	9201 07R3 35	1 1/4	28,10	3,53	0,002	10	-
9205 48R1 35	9205 48R3 35	1 1/2	32,92	3,53	0,002	10	-
9205 50R1 35	9205 50R3 35	2	40,64	5,33	0,003	10	-
9205 51R1 35	9205 51R3 35	2 1/4	47,00	5,33	0,004	10	-
9205 54R1 35	9205 54R3 35	2 3/4	59,70	5,33	0,005	10	-
9205 56R1 35	9205 56R3 35	3 1/2	75,56	5,33	0,01	10	-
9205 57R1 35	9205 57R3 35	4	91,45	5,33	0,01	10	-
9205 58R1 35	9205 58R3 35	5	113,66	5,33	0,01	10	-

## 1.05 Verschraubungen • Unions

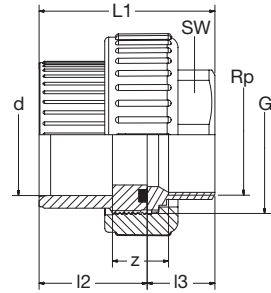

621.53.02 PVC-U-GJMW Ü-Verschraubung IG-zyl Flachdichtring-EPDM grau  
PVC-U-GJMW Transition-Union female-thread-cyl flat-gasket-EPDM grey

Teil / Item	d x Rp [mm x Inch]	Thread	DN [mm]	G [Inch]	L1 [mm]	I2 [mm]	I3 [mm]	z [mm]	SW [mm]	P [bar]	KG	VE1	VE2
1T50 0542 32	16 x 3/8	f	10	3/4	43	17	23	19	22	10	0,080	1	-
1T50 0643 32	20 x 1/2	f	15	1	47	19	25	19	25	10	0,12	1	-
1T50 0745 32	25 x 3/4	f	20	1 1/4	53	22	28	19	31	10	0,26	1	-
1T50 0845 32	32 x 1	f	25	1 1/2	59	25	31	20	38	10	0,30	1	-
1T50 0945 32	40 x 1 1/4	f	32	2	65	29	33	20	47	10	0,48	1	-
1T50 1048 32	50 x 1 1/2	f	40	2 1/4	73	34	36	23	53	10	0,59	1	-
1T50 1150 32	63 x 2	f	50	2 3/4	86	41	42	24	66	10	0,80	1	-
1T50 1253 32	75 x 2 1/2	f	65	3 1/2	96	47	46	25	83	10	1,29	1	-
1T50 1355 32	90 x 3	f	80	4	111	56	52	30	96	10	1,73	1	-

Anschluss für Metallgewinde, keine Lagerware, nur komplett lieferbar.  
Connection for metal thread, no stock item, only available completely.

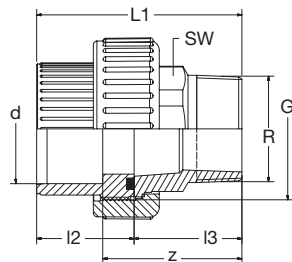

621.53.07 PVC-U-GJMW Ü-Verschraubung AG-keg Flachdichtring-EPDM grau  
PVC-U-GJMW Transition-Union male-thread-con flat-gasket-EPDM grey

Teil / Item	d x R [mm x Inch]	Thread	DN [mm]	G [Inch]	L1 [mm]	I2 [mm]	I3 [mm]	z [mm]	SW [mm]	P [bar]	KG	VE1	VE2
1T50 0572 32	16 x 3/8	m	10	3/4	56	17	39	45	21	10	0,090	1	-
1T50 0673 32	20 x 1/2	m	15	1	62	19	43	49	25	10	0,18	1	-
1T50 0775 32	25 x 3/4	m	20	1 1/4	71	22	49	55	31	10	0,27	1	-
1T50 0876 32	32 x 1	m	25	1 1/2	78	25	53	59	38	10	0,34	1	-
1T50 0977 32	40 x 1 1/4	m	32	2	87	29	58	65	47	10	0,59	1	-
1T50 1078 32	50 x 1 1/2	m	40	2 1/4	96	34	62	68	53	10	0,72	1	-
1T50 1180 32	63 x 2	m	50	2 3/4	112	41	71	76	66	10	1,05	1	-

Anschluss für Metallgewinde, keine Lagerware, nur komplett lieferbar.  
Connection for metal thread, no stock item, only available completely.

# 1.05 Verschraubungen • Unions

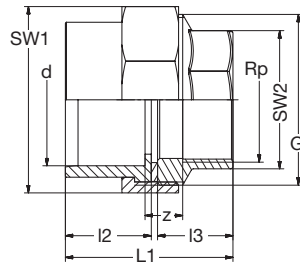

621.54.02 PVC-U-V2A Ü-Verschraubung IG-zyl Flachdichtring-EPDM grau  
 PVC-U-Stainless Steel Transition-Union female-thread-cyl flat-gasket-EPDM grey

Teil / Item	d x Rp [mm x Inch]	Thread	DN [mm]	G [Inch]	L1 [mm]	L2 [mm]	L3 [mm]	z [mm]	SW1 [mm]	SW2 [mm]	P [bar]	KG	VE1	VE2
1V50 0643 12	20 x 1/2	f	15	1	47	19	25	18	38	27	10	0,13	1	-
1V50 0745 12	25 x 3/4	f	20	1 1/4	53	22	28	19	47	32	10	0,23	1	-
1V50 0846 12	32 x 1	f	25	1 1/2	59	25	31	20	52	38	10	0,30	1	-
1V50 0947 12	40 x 1 1/4	f	32	2	65	29	33	20	66	47	10	0,48	1	-
1V50 1048 12	50 x 1 1/2	f	40	2 1/4	73	34	36	23	72	53	10	0,59	1	-
1V50 1150 12	63 x 2	f	50	2 3/4	86	41	42	24	87	65	10	0,97	1	-
1V50 1253 12	75 x 2 1/2	f	65	3 1/2	96	47	46	25	110	82	10	1,60	1	-
1V50 1355 12	90 x 3	f	80	4	111	56	52	30	120	95	10	2,09	1	-
1V50 1457 12	110 x 4	f	100	5	129	66	60	32	150	123	10	3,39	1	-

Anschluss für Metallgewinde, nur komplett lieferbar.  
 Connection for metal thread, only available completely.

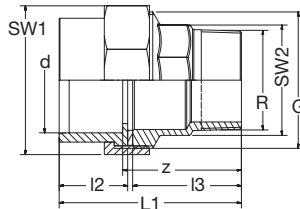

621.54.07 PVC-U-V2A Ü-Verschraubung AG-keg Flachdichtring-EPDM grau  
 PVC-U-Stainless Steel Transition-Union male-thread-con flat-gasket-EPDM grey

Teil / Item	d x R [mm x Inch]	Thread	DN [mm]	G [Inch]	L1 [mm]	L2 [mm]	L3 [mm]	z [mm]	SW1 [mm]	SW2 [mm]	P [bar]	KG	VE1	VE2
1V50 0673 12	20 x 1/2	m	15	1	65	19	43	49	38	27	10	0,16	1	-
1V50 0775 12	25 x 3/4	m	20	1 1/4	74	22	49	55	47	27	10	0,26	1	-
1V50 0876 12	32 x 1	m	25	1 1/2	81	25	53	59	52	34	10	0,36	1	-
1V50 0977 12	40 x 1 1/4	m	32	2	90	29	58	64	66	43	10	0,58	1	-
1V50 1078 12	50 x 1 1/2	m	40	2 1/4	99	34	62	68	72	50	10	0,72	1	-
1V50 1180 12	63 x 2	m	50	2 3/4	115	41	71	77	87	61	10	1,10	1	-
1V50 1283 12	75 x 2 1/2	m	65	3 1/2	128	47	78	84	110	80	10	1,91	1	-
1V50 1385 12	90 x 3	m	80	4	146	56	87	95	120	80	10	2,43	1	-
1V50 1487 12	110 x 4	m	100	5	169	66	100	102	150	123	10	4,26	1	-

Anschluss für Metallgewinde, nur komplett lieferbar.  
 Connection for metal thread, only available completely.

# 1.06 Flanschverbindung • Flange connection

## Bundbuchse (BB) in verschiedenen Ausführungen für den Einsatz von Flach- und Runddichtungen.

Weitere Informationen zu Flanschen und Dichtungen finden Sie unter 6. Zubehör.

## Flange adaptor socket (BB) in various designs for the use of flat and O-ring gaskets.

More information about flanges and gaskets see 6. Accessories.

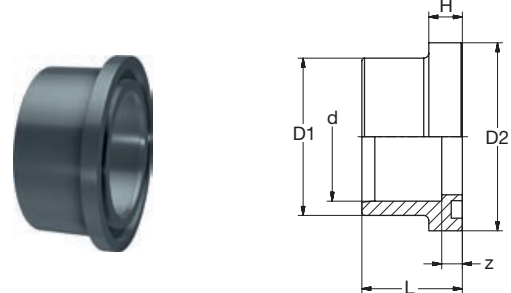
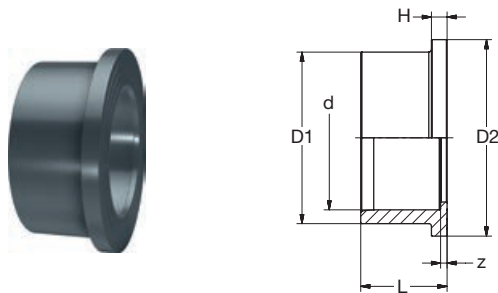
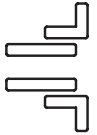

621.79.01 PVC-U Bundbuchse gerillt grau  
PVC-U Flange adaptor socket grooved grey

Teil / Item	d [mm]	DN [mm]	D1 [mm]	D2 [mm]	H [mm]	L [mm]	z [mm]	PN [bar]	KG	VE1	VE2
1330 06F0 12	20	15	27	34	6	19	3	16	0,010	10	200
1330 07F0 12	25	20	33	41	7	22	3	16	0,015	10	100
1330 08F0 12	32	25	41	50	7	25	3	16	0,023	10	100
1330 09F0 12	40	32	50	61	8	29	3	16	0,039	10	100
1330 10F0 12	50	40	61	73	8	34	3	16	0,065	10	60
1330 11F0 12	63	50	76	90	9	41	3	16	0,10	2	20
1330 12F0 12	75	65	90	106	10	47	3	16	0,16	2	14
1330 13F0 12	90	80	108	125	11	56	5	16	0,26	2	18
1330 14F0 12	110	100	131	150	12	66	5	16	0,42	2	8
1330 16F0 12	140	125	165	188	14	81	5	16	0,77	2	6
1330 17F0 12	160	150	188	213	16	91	5	16	1,10	2	8
1330 20F0 12	225	200	248	274	25	125	6	10	1,70	1	6
1330 21F0 32	250	225	282	328	25	139	9	10	2,18	1	-
1330 22F0 32	280	250	306	327	27	154	9	10	2,83	1	-
1330 23F0 32	315	300	342	377	30	173	9	10	4,08	1	-

621.81.01 PVC-U Bundbuchse O-Ring-Kammer grau  
PVC-U Flange adaptor socket O-Ring-chamber grey

Teil / Item	d [mm]	DN [mm]	D1 [mm]	D2 [mm]	H [mm]	L [mm]	z [mm]	PN [bar]	KG	VE1	VE2
1330 05R0 12	16	10	22	29	9	20	6	16	0,006	10	250
1330 06R0 12	20	15	27	34	9	22	6	16	0,011	10	200
1330 07R0 12	25	20	33	41	10	25	6	16	0,017	10	100
1330 08R0 12	32	25	41	50	10	28	6	16	0,026	10	100
1330 09R0 12	40	32	50	61	13	34	8	16	0,044	10	100
1330 10R0 12	50	40	61	73	13	39	8	16	0,070	10	60
1330 11R0 12	63	50	76	90	14	46	8	16	0,12	2	20
1330 12R0 12	75	65	90	106	15	52	8	16	0,19	2	12
1330 13R0 12	90	80	108	125	16	61	10	16	0,30	2	18
1330 14R0 12	110	100	131	150	18	72	11	16	0,46	2	8
1330 16R0 12	140	125	165	188	20	87	11	16	0,84	2	6
1330 17R0 12	160	150	188	213	22	97	11	16	1,21	2	8
1330 20R0 12	225	200	248	274	31	131	12	10	1,88	1	6

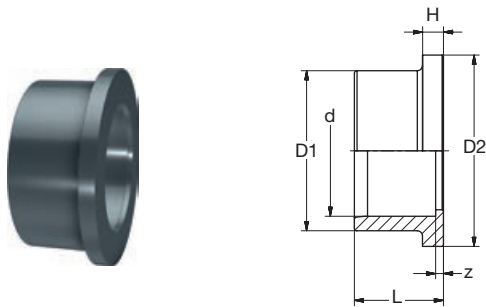

621.80.01 PVC-U Bundbuchse glatt grau  
PVC-U Flange adaptor socket plain grey

Teil / Item	d [mm]	DN [mm]	D1 [mm]	D2 [mm]	H [mm]	L [mm]	z [mm]	PN [bar]	KG	VE1	VE2
1330 0500 12	16	10	22	29	6	17	3	16	0,006	10	250
1330 0600 12	20	15	27	34	6	19	3	16	0,009	10	200
1330 0700 12	25	20	33	41	7	22	3	16	0,014	10	100
1330 0800 12	32	25	41	50	7	25	3	16	0,023	10	100
1330 0900 12	40	32	50	61	8	29	3	16	0,040	10	100
1330 1000 12	50	40	61	73	8	34	3	16	0,062	10	60
1330 1100 12	63	50	76	90	9	41	3	16	0,10	2	20
1330 1200 12	75	65	90	106	10	47	3	16	0,16	2	14
1330 1300 12	90	80	108	125	11	56	5	16	0,26	2	18
1330 1400 12	110	100	131	150	12	66	5	16	0,42	2	8
1330 1600 12	140	125	165	188	14	81	5	16	0,78	2	6
1330 1700 12	160	150	188	213	16	91	5	16	1,14	2	8
1330 2000 12	225	200	248	274	25	125	6	10	1,74	1	6

# 1.06 Flanschverbindung • Flange connection

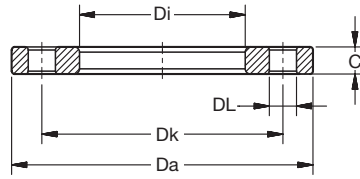

621.70.00 PVC-U Losflansch DIN-EN grau  
PVC-U Backing flange DIN-EN grey

Teil / Item	d [mm]	BB	VB	PN gebohrt drilled	DN [mm]	Da [mm]	Di [mm]	C [mm]	nL [mm]	DL [mm]	DK [mm]	KG	VE1	VE2
9131 05E1 32	16	•	•	10/16	10	90	23	12	4	14	60	0,08	5	-
9131 06E1 32	20	•	•	10/16	15	95	28	12	4	14	65	0,09	5	-
9131 07E1 32	25	•	•	10/16	20	105	34	14	4	14	75	0,12	5	-
9131 08E1 12	32	•	•	10/16	25	115	42	15	4	14	85	0,14	10	-
9131 09E1 12	40	•	•	10/16	32	140	51	15	4	18	100	0,20	10	-
9131 10E1 12	50	•	•	10/16	40	150	62	16	4	18	110	0,24	10	-
9131 11E1 12	63	•	•	10/16	50	165	78	18	4	18	125	0,31	10	-
9131 12E1 12	75	•	•	10/16	65	185	92	19	4	18	145	0,40	5	-
9132 13E1 12	90	•	•	10/16	80	200	110	20	8	18	160	0,48	5	-
9132 14E1 12	110	•	•	10/16	100	220	133	22	8	18	180	0,60	5	-
9132 16E1 12	140	•	•	10/16	125	250	167	26	8	18	210	0,74	5	-
9132 17E1 12	160	•	•	10/16	150	285	190	28	8	22	240	1,05	5	-
9132 20E2 32	225	•	•	10	200	340	250	30	8	22	295	1,67	5	-
9132 21E2 32	250	•	•	10	250	370	277	36	8	22	325	1,80	1	-
9132 22E2 32	280	•	•	10	250	399	307	32	12	22	350	1,84	1	-
9132 23E2 32	315	•	•	10	300	450	345	34	12	22	400	2,45	1	-

BB = Bundbuchse • Flange adaptor socket  
VB = Vorschweißbund • Flange adaptor spigot

**Zubehör Flanschverbindung B-Buchse PVC-U  
Accessories Flange Connection socket PVC-U**

 Losflansch  
Flange loose

 Blindflansch  
Flange blind

d [mm]	DN [mm]	PVC-U		PP-St		PP-GGG	PP-St	PP-St			
		DIN/EN				ANSI			DIN/EN		ANSI
		PN10/16	PN10	PN10/16	PN10	150 lbs			PN10/16	PN10	150 lbs
16	10	9131 05E1 32									
20	15	9131 06E1 32		9141 06E1 35			9141 06A2 38			9144 06A2 38	
25	20	9131 07E1 32		9141 07E1 15			9141 07A2 38	9144 07E1 35		9144 07A2 38	
32	25	9131 08E1 12		9141 08E1 15			0141 08A2 38	9144 08E1 35		9144 08A2 38	
40	32	9131 09E1 12		9141 09E1 15			9141 09A2 38	9144 09E1 35		9144 09A2 38	
50	40	9131 10E1 12		9141 10E1 15			9141 10A2 38	9144 10E1 35		9144 10A2 38	
63	50	9131 11E1 12		9141 11E1 15		9151 11A2 25		9144 11E1 35		9144 11A2 38	
75	65	9131 12E1 12		9141 12E1 15			9141 12A2 38	9144 12E1 35		9144 12A2 38	
90	80	9131 13E1 12		9142 13E1 15			9141 13A2 38	9144 13E1 35		9144 13A2 38	
110	100	9131 14E1 12		9142 14E1 15		9152 14A2 25		9144 14E1 35		9144 14A2 38	
140	125	9131 16E1 12		9142 16E1 15				9144 16E1 35			
160	150	9131 17E1 12		9142 17E1 15				9144 17E1 35		9144 17A2 38	
225	200		9132 20E2 32		9142 20E2 15				9144 19E2 35		
250	225		9132 21E2 32						9144 21E2 35	9144 21A2 38	
280	250		9132 22E2 32						9144 21E2 35		
315	300		9132 23E2 32						9144 23E2 35	9144 23A2 38	

 Flachdichtringe für BB gerillt und flach  
Flat-Gasket for flange adaptor grooved and plain

 mit Stahl-Einlage  
with Steel-inlay

d [mm]	DN [mm]	EPDM	EPDM-St	NBR-St
		Wasser/Water	Wasser/Water	Gas/Gas
		PN10	PN10	
16	10	9201 05F1 35	9202 05F1 35	9202 05F2 35
20	15	9201 06F1 35	9202 06F1 35	9202 06F2 35
25	20	9201 07F1 35	9202 07F1 35	9202 07F2 35
32	25	9201 08F1 35	9202 08F1 35	9202 08F1 35
40	32	9201 09F1 35	9202 09F1 35	9202 09F2 35
50	40	9201 10F1 35	9202 10F1 35	9202 10F2 35
63	50	9201 11F1 35	9202 11F1 35	9202 11F2 35
75	65	9201 12F1 35	9202 12F1 35	9202 12F2 35
90	80	9201 13F1 35	9202 13F1 35	9202 13F2 35
110	100	9201 14F1 35	9202 14F1 35	9202 14F2 35
140	125	9201 16F1 35	9202 16F1 35	9202 16F2 35
160	150	9201 17F1 35	9202 17F1 35	9202 17F2 35
225	200	9201 20F1 35	9202 20F1 35	9202 20F2 35
250	225		9202 21F1 35	9202 21F2 35
280	250		9202 22F1 35	9202 22F2 35
315	300		9202 23F1 35	9202 23F2 35

 Runddichtringe für BB mit O-Ring-Kammer  
O-Ring-Gasket for flange adaptor with O-Ring chamber.

d [mm]	DN [mm]	EPDM	FKM (FPM)
		Wasser/Water	
		PN10	
16	10	9201 05R1 35	9201 05R3 35
20	15	9201 06R1 35	9201 06R3 35
25	20	9201 07R1 35	9201 07R3 35
32	25	9201 08R1 35	9201 08R3 35
40	32	9201 09R1 35	9201 09R3 35
50	40	9201 10R1 35	9201 10R3 35
63	50	9201 11R1 35	9201 11R3 35
75	65	9201 12R1 35	9201 12R3 35
90	80	9201 13R1 35	9201 13R3 35
110	100	9201 14R1 35	9201 14R3 35
140	125	9201 16R1 35	9201 16R3 35
160	150	9201 17R1 35	9201 17R3 35
225	200	9201 20R1 35	9201 20R3 35
250	225		
280	250		
315	300		

\* Nicht für PVC-U Flansche!

\* Not for PVC-U flanges!

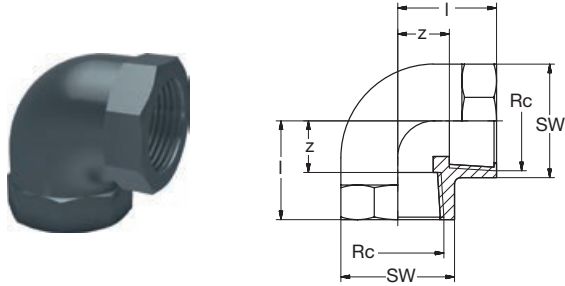

621.10.16 PVC-U Winkel 90° IG-keg grau  
PVC-U Elbow 90° female-thread-con grey

Teil / Item	Rc [Inch]	Thread	l [mm]	z [mm]	SW [mm]	P [bar]	KG	VE1	VE2
1620 43C0 12	1/2	f	28	14	30	10	0,030	10	120
1620 45C0 12	3/4	f	33	17	36	10	0,048	10	80
1620 46C0 12	1	f	40	22	46	10	0,10	10	80
1620 47C0 12	1 1/4	f	49	28	55	10	0,15	10	90
1620 48C0 12	1 1/2	f	59	38	65	10	0,27	10	30

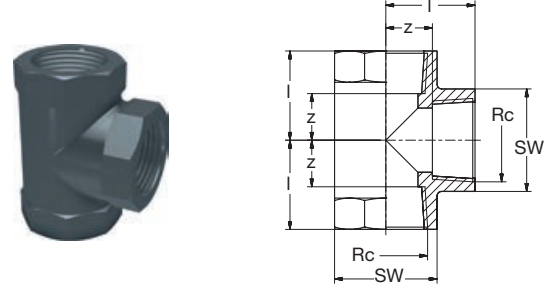

621.20.16 PVC-U T-Stück 90° IG-keg grau  
PVC-U Tee 90° female-thread-con grey

Teil / Item	Rc [Inch]	Thread	l [mm]	z [mm]	SW [mm]	P [bar]	KG	VE1	VE2
1640 43C0 12	1/2	f	28	14	30	10	0,040	10	80
1640 45C0 12	3/4	f	33	17	36	10	0,062	10	50
1640 46C0 12	1	f	40	22	46	10	0,13	10	60
1640 47C0 12	1 1/4	f	49	28	55	10	0,20	10	30
1640 48C0 12	1 1/2	f	59	38	65	10	0,35	10	20

PVC-U

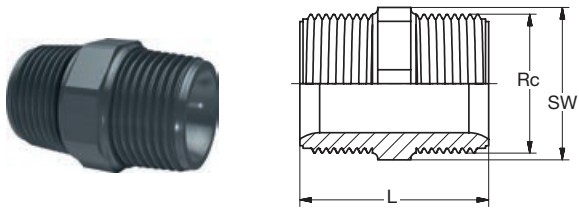

621.91.19 PVC-U Doppelnippel AG-keg grau  
PVC-U Hexagon nipple male-thread-con grey

Teil / Item	Rc [Inch]	Thread	DN [mm]	L [mm]	SW [mm]	P [bar]	KG	VE1	VE2
1610 7200 12	3/8	f	10	34	22	10	0,010	10	200
1610 7300 12	1/2	f	15	42	24	10	0,014	10	200
1610 7500 12	3/4	f	20	47	30	10	0,022	10	120
1610 7600 12	1	f	25	53	36	10	0,033	10	80
1610 7700 12	1 1/4	f	32	56	46	10	0,049	10	120
1610 7800 12	1 1/2	f	40	57	55	10	0,067	10	60
1610 8000 12	2	f	50	68	65	10	0,11	10	90

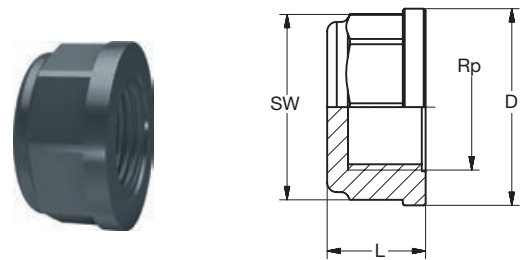

621.96.06 PVC-U Kappe IG-zyl grau  
PVC-U Cap female-thread-cyl grey

Teil / Item	Rp [Inch]	Thread	D [mm]	L [mm]	SW [mm]	P [bar]	KG	VE1	VE2
1690 4000 12	1/8	f	20	14	17	10	0,004	10	1000
1690 4100 12	1/4	f	26	16	22	10	0,007	10	400
1690 4200 12	3/8	f	31	19	27	10	0,011	10	200
1690 4300 12	1/2	f	37	21	32	10	0,018	10	200
1690 4500 12	3/4	f	43	24	36	10	0,023	10	160
1690 4600 12	1	f	52	26	46	10	0,039	10	100
1690 4700 12	1 1/4	f	62	29	55	10	0,055	10	110
1690 4800 12	1 1/2	f	66	31	60	10	0,069	10	100
1690 5000 12	2	f	82	36	75	10	0,12	5	75

# 1.07 Formteile mit Kunststoff-Gewinde • Fittings with plastic-thread

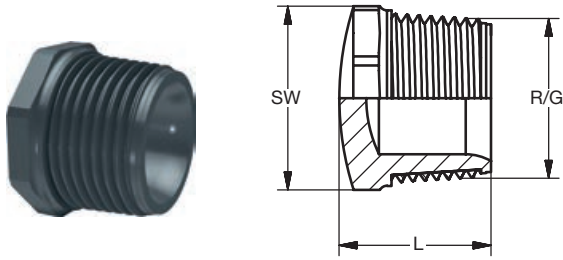

621.96.19 PVC-U Stopfen AG-keg grau  
PVC-U Plug male-thread-con grey

Teil / Item	R [Inch]	Thread	L [mm]	SW [mm]	P [bar]	KG	VE1	VE2
1670 7200 12	3/8	m	21	22	10	0,010	10	200
1670 7300 12	1/2	m	27	24	10	0,011	10	150
1670 7500 12	3/4	m	29	30	10	0,016	10	150
1670 7600 12	1	m	32	36	10	0,027	10	120
1670 7700 12	1 1/4	m	36	46	10	0,041	10	80
1670 7800 12	1 1/2	m	37	55	10	0,62	10	100
1670 8000 12	2	m	42	65	10	0,10	5	60

621.96.09 PVC-U Stopfen AG-zyl grau  
PVC-U Plug male-thread-cyl grey

Teil / Item	G [Inch]	Thread	L [mm]	SW [mm]	P [bar]	KG	VE1	VE2
1670 72G0 32	3/8	m	21	22	10	0,010	10	200
1670 73G0 12	1/2	m	27	24	10	0,016	10	150
1670 75G0 32	3/4	m	29	30	10	0,010	10	150
1670 76G0 32	1	m	32	36	10	0,020	10	120
1670 77G0 32	1 1/4	m	36	46	10	0,050	10	80
1670 78G0 32	1 1/2	m	37	55	10	0,060	10	100
1670 80G0 32	2	m	42	65	10	0,10	5	60
1670 83G0 32	2 1/2	m	59	80	10	0,18	1	-
1670 85G0 32	3	m	76	93	10	0,26	1	-
1670 87G0 32	4	m	84	131	10	0,64	1	-

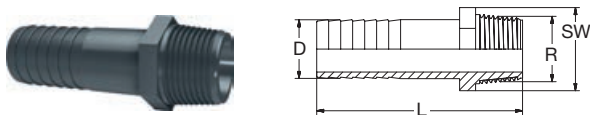

621.96.07 PVC-U Druckschlauchtülle AG-keg grau  
PVC-U Hose nozzle male-thread-con grey

Teil / Item	R [Inch]	Thread	DN [mm]	D [mm]	L [mm]	SW [mm]	P [bar]	KG	VE1	VE2
1680 7100 32	1/4	m	8	12	51	14	10	0,010	10	-
1680 7200 32	3/8	m	10	16	57	19	10	0,010	10	-
1680 7300 32	1/2	m	15	20	73	22	10	0,020	10	-
1680 7500 32	3/4	m	20	25	79	27	10	0,030	10	-
1680 7600 32	1	m	25	30	89	36	10	0,040	10	-
1680 7700 32	1 1/4	m	32	40	100	46	10	0,080	10	-
1680 7800 32	1 1/2	m	40	50	114	52	10	0,11	10	-
1680 8000 32	2	m	50	60	132	65	10	0,13	10	-

# 1.08 Kugelhähne • Ball valves

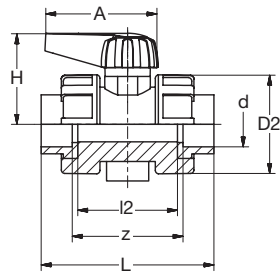

621.342.200 EPDM 621.342.205 FKM (FPM) PVC-U Kugelhahn verschraubt Runddichtring-EPDM grau  
PVC-U Ball valve with Union-nuts O-Ring-gasket-EPDM grey

Teil / Item	Teil / Item	d [mm]	DN [mm]	D2 [mm]	L [mm]	l2 [mm]	A [mm]	H [mm]	z [mm]	P [bar]	KG	VE1	VE2
1910 06R1 22	1910 06R3 22	20	15	50	95	57	66	48	63	16	0,14	1	-
1910 07R1 22	1910 07R3 22	25	20	59	110	66	81	57	72	16	0,23	1	-
1910 08R1 22	1910 08R3 22	32	25	70	122	72	82	65	78	16	0,32	1	-
1910 09R1 22	1910 09R3 22	40	32	86	143	85	92	83	91	16	0,53	1	-
1910 10R1 22	1910 10R3 22	50	40	100	158	90	92	89	96	16	0,69	1	-
1910 11R1 22	1910 11R3 22	63	50	126	183	101	142	115	107	16	1,22	1	-

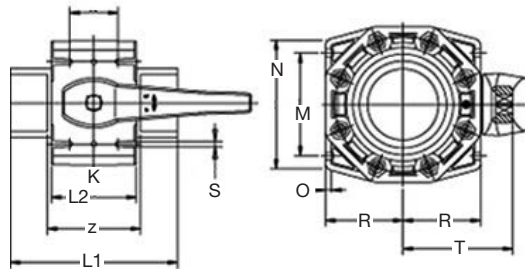

621.342.250 EPDM 621.342.275 FKM (FPM) PVC-U Kugelhahn Muffenflansch Dichtung-EPDM/FKM grau  
PVC-U Ball valve socket-flange gasket-EPDM/FKM grey

Teil / Item	Teil / Item	d [mm]	DN [mm]	K [mm]	L [mm]	L2 [mm]	M [mm]	N [mm]	O [mm]	R [mm]	S [mm]	T [mm]	z [mm]	P [bar]	KG	VE1	VE2
191M 12R1 32	191M 12R3 32	75	65	60	206	112	110	130	5,5	84,0	8,5	127	118	10	6,66	1	-
191M 13R1 32	191M 13R3 32	90	80	60	236	124	124	140	6,0	92,5	8,5	135	134	10	7,80	1	-
191M 14R1 32	191M 14R3 32	110	100	80	276	144	136	160	8,0	102,5	8,5	148	154	10	9,97	1	-

# 1.09 Ventile • Valves

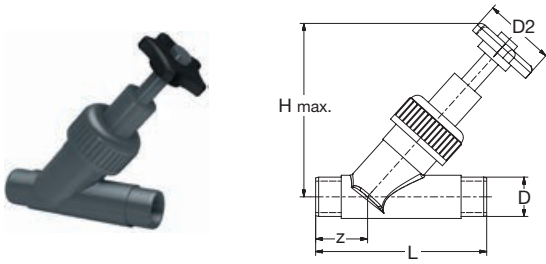

621.300.000 PVC-U Ventil Schrägsitz Runddichtring-PB grau  
PVC-U Valve angle-seat O-Ring-gasket-PB grey

Teil / Item	D [mm]	DN [mm]	D2 [mm]	L [mm]	H [mm]	z [mm]	P [bar]	KG	VE1	VE2
1930 0500 32	16	10	50	114	105	24	10	0,12	1	
1930 0600 32	20	15	63	124	135	33	10	0,23	1	
1930 0700 32	25	20	63	144	135	33	10	0,25	1	
1930 0800 32	32	25	63	154	143	37	10	0,35	1	
1930 0900 32	40	32	80	174	182	48	10	0,62	1	
1930 1000 32	50	40	80	194	204	48	10	1,09	1	
1930 1100 32	63	50	100	224	276	60	10	1,52	1	

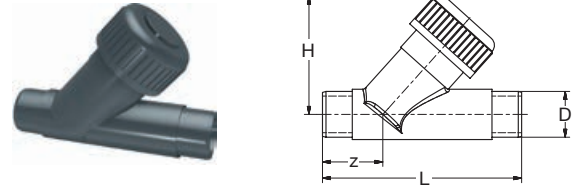

621.303.000 PVC-U Ventil Schrägsitz Rückschlag Runddichtring-EPDM grau  
PVC-U Valve angle-seat non-return O-Ring-gasket-EPDM grey

Teil / Item	D [mm]	DN [mm]	L [mm]	H [mm]	z [mm]	P [bar]	KG	VE1	VE2
1930 06R0 32	20	15	124	65	33	10	0,19	1	-
1930 07R0 32	25	20	144	75	33	10	0,21	1	-
1930 08R0 32	32	25	154	90	37	10	0,32	1	-
1930 09R0 32	40	32	174	102	48	10	0,51	1	-
1930 10R0 32	50	40	194	123	48	10	0,84	1	-
1930 11R0 32	63	50	224	144	60	10	1,40	1	-

Horizontal und vertikal einsetzbar • Horizontal and vertical use.

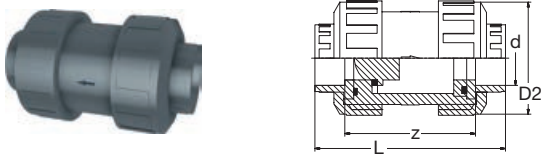

621.360.000 PVC-U Ventil Rückschlag Runddichtring-EPDM grau  
PVC-U Valve non-return O-Ring-gasket-EPDM grey

Teil / Item	d [mm]	DN [mm]	D2 [mm]	L [mm]	z [mm]	P [bar]	KG	VE1	VE2
1940 05R0 32	16	10	50	81	53	16	0,10	1	50
1940 06R0 32	20	15	50	81	49	16	0,11	1	50
1940 07R0 32	25	20	60	94	56	16	0,17	1	32
1940 08R0 32	32	25	68	107	63	16	0,25	1	22
1940 09R0 32	40	32	80	124	72	16	0,40	1	27
1940 10R0 32	50	40	96	146	84	16	0,66	1	18
1940 11R0 32	63	50	116	170	94	16	1,12	1	10
1940 12R0 32	75	65	145	218	130	10	1,74	1	5
1940 13R0 32	90	80	166	250	148	10	2,77	1	3
1940 14R0 32	110	100	210	290	168	10	4,74	1	2

Federbelastet, Edelstahlfeder PTFE-ummantelt.  
Spring-loaded, Stainless steel spring PTFE-coated.

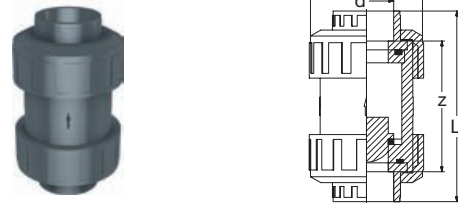

21.10.140 PVC-U Ventil Fuß Runddichtring-EPDM grau  
PVC-U Valve foot O-Ring-gasket-EPDM grey

Teil / Item	d [mm]	DN [mm]	D2 [mm]	L [mm]	z [mm]	P [bar]	KG	VE1	VE2
1940 05F0 32	16	10	50	81	53	16	0,095	1	50
1940 06F0 32	20	15	50	81	49	16	0,12	1	50
1940 07F0 32	25	20	60	94	56	16	0,22	1	32
1940 08F0 32	32	25	68	107	63	16	0,27	1	22
1940 09F0 32	40	32	80	124	72	16	0,49	1	27
1940 10F0 32	50	40	96	146	84	16	0,75	1	18
1940 11F0 32	63	50	116	170	94	16	1,35	1	10
1940 12F0 32	75	65	145	218	130	10	1,89	1	2
1940 13F0 32	90	80	166	250	148	10	3,31	1	2
1940 14F0 32	110	100	210	290	168	10	5,08	1	2

Unsere Polyethylen gespritzten Formteile zeichnen sich durch hervorragende physikalische und mechanische Merkmale aus. Dadurch ergeben sich vielfältige Einsatzmöglichkeiten.

Durch die feine Oberflächenstruktur sind PE-Formteile ein idealer Werkstoff für die Beförderung von Gasen und Flüssigkeiten.

Die hervorragende UV-Beständigkeit bietet die Möglichkeit zur Außeninstallation ohne Aufwand für zusätzliche Schutzmaßnahmen. Unsere Formteile bewähren sich seit Jahrzehnten in der Gas- und Wasserversorgung.

### Eigenschaften

- Geringes Eigengewicht
- UV-Beständigkeit
- Hohe chemische Beständigkeit
- Hohe Schlagzähigkeit bei tiefen Temperaturen
- Korrosionsbeständigkeit
- Licht- und Witterungsbeständigkeit
- Hohe Abriebfestigkeit
- Hervorragende Verarbeitungseigenschaften

### Werkstoff

Polyethylen (PE100) klassifiziert nach der Mindestlangzeitfestigkeit (MRS), Farbe Schwarz.

### Verbindungstechnik

- Heizelement-Stumpf-Schweißung
- Heizwendel-Muffen-Schweißung
- Flanschverbindung



## 2 PE100

Our injection moulded Polyethylene fittings are characterised by excellent physical and mechanical properties. This results in multiple applications.

Through the fine surface structure, injection moulded PE fittings are ideal for transporting gases and liquids. The excellent UV resistance offers the possibility for outside installation without further need for additional protection effort. Our injection moulded fittings have been approved and applied for decades in gas and water supply.

### Properties

- Low dead weight
- UV resistance
- High resistance to chemicals
- High impact strength at low temperatures
- Corrosion resistance
- Light resistance and weather resistant
- High abrasion resistance
- Excellent processing properties

### Material

Polyethylene (PE100) classified according to minimum long-term strength (MRS), colour black.

### Joining technology

- Butt-welding
- Electrofusion socket-welding
- Flange connection



## 2.01 Formteile lang • Fittings long

### 2.01.01 Winkel lang • Elbows long

PE 4

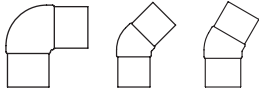

### 2.01.02 T-Stücke + Abzweige lang Tee's + Branches long

PE 6

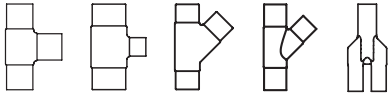

### 2.01.03 Reduktionen + Kappen lang Reducers + Caps long

PE 9

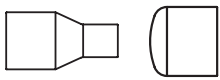

### 2.01.04 Übergänge lang Transitions long

PE 12

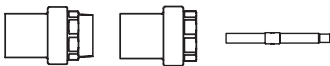

### 2.01.05 Verschraubungen lang Unions long

PE 13

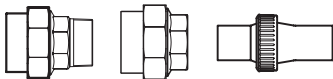

### 2.01.06 Flanschverbindung lang Flange connection long

PE 15

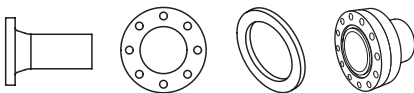

### 2.01.07 Kugelhähne lang Ball Valves long

PE 20

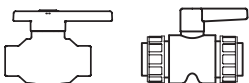

## 2.03 E-Formteile • E-Fittings

PE 29



## 2.02 Formteile kurz • Fittings short

### 2.02.01 Bögen + Winkel kurz Bends + Elbows short

PE 21

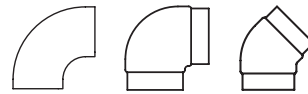

### 2.02.02 T-Stücke kurz Tee's short

PE 23

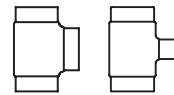

### 2.02.03 Reduktionen kurz Reducers short

PE 24



### 2.02.04 Übergänge kurz Transitions short

PE 26



### 2.02.05 Flanschverbindung kurz Flange connection short

PE 27

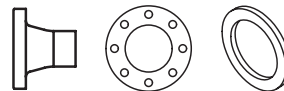

## 2.04 Bögen nahtlos • Bends seamless

PE 32



## 2.01 Formteile LANG • Fittings LONG

### PE100 Formteile mit langen Schweißenden SDR11/17 schwarz

gespritzt, für die Heizelement-Stumpf-Schweißung und Heizwendel-Muffen-Schweißung

### PE100 Fittings with long spigots SDR11/17 black

injection moulded, for butt-welding and electrofusion socket-welding

#### Werkstoff

PE100, schwarz. Das Material entspricht den Anforderungen der aktuellen KTW-Leitlinie des Umweltbundesamtes (UBA).

#### Geometrische Eigenschaften

Außendurchmesser und Wanddicke entsprechend EN 1555 und EN 12201.

Toleranzen bei den Z-Maßangaben sind abhängig von der Dimension. Bis d/D 160 = +/- 3 mm. Ab d/D 180 = +/- 10 mm.

#### Ausführung

Geeignet für Heizelement-Stumpf-Schweißung und Heizwendel-Muffen-Schweißung nach DVS Richtlinie 2207. Schweiß-Geräte und Schweiß-Werkzeuge sollten der DVS Richtlinie 2208 entsprechen.

#### Material

PE100, black. The material complies with the requirements of the KTW guideline of the German Federal Environmental Agency (UBA).

#### Geometric Properties

Outside diameter and wall thickness according to EN 1555 and EN 12201.

Tolerances of z-sizes depend on the dimension. Up to d/D 160 = +/- 3 mm and from d/D 180 = +/- 10 mm.

#### Type

Suitable for butt-welding and electrofusion socket-welding according to DVS technical code 2207. Welding equipment according to DVS technical code 2208.

## 2.01.01 Winkel lang • Elbows long

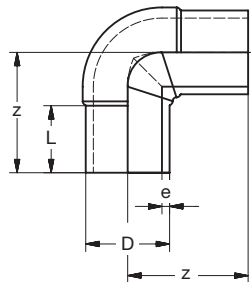

25.10.01.103 PE100 Winkel 90° lang **SDR11** schwarz  
PE100 Elbow 90° long **SDR11** black

Teil / Item	D [mm]	e [mm]	L [mm]	z [mm]	KG	VE1	VE2
2413 0790 15	25	2,3	42	63	0,023	5	100
2413 0890 15	32	3,0	47	72	0,043	5	60
2413 0990 15	40	3,7	44	69	0,069	5	100
2413 1090 15	50	4,6	61	95	0,12	5	60
2413 1190 15	63	5,8	67	115	0,27	5	35
2413 1290 15	75	6,9	78	128	0,42	2	20
2413 1390 15	90	8,2	78	141	0,62	2	12
2413 1490 15	110	10,0	85	157	1,05	2	10
2413 1590 15	125	11,4	100	170	1,67	1	6
2413 1690 15	140	12,7	105	198	2,21	1	3
2413 1790 15	160	14,6	117	220	3,08	1	2
2413 1890 15	180	16,4	114	221	4,12	1	-
2413 1990 15	200	18,2	126	249	5,75	1	-
2413 2090 15	225	20,5	135	269	7,94	1	-
2413 2190 15	250	22,7	148	307	10,2	1	-
2413 2290 15	280	25,4	156	332	13,6	1	-
2413 2390 15	315	28,6	170	359	18,8	1	-
2413 2490 15	355	32,2	170	410	30,2	1	-
2413 2590 15	400	36,6	187	469	41,7	1	-
2413 2690 15	450	40,9	202	522	58,9	1	-
2413 2790 15	500	45,4	222	562	79,5	1	-

25.10.01.063 PE100 Winkel 90° lang **SDR17** schwarz  
PE100 Elbow 90° long **SDR17** black

Teil / Item	D [mm]	e [mm]	L [mm]	z [mm]	KG	VE1	VE2
2414 1190 15	63	3,8	67	115	0,23	5	35
2414 1290 15	75	4,5	78	128	0,36	2	20
2414 1390 15	90	5,4	78	141	0,52	2	12
2414 1490 15	110	6,6	85	157	0,89	2	10
2414 1590 15	125	7,4	100	170	1,42	1	6
2414 1690 15	140	8,3	105	198	1,71	1	3
2414 1790 15	160	9,5	117	220	2,33	1	2
2414 1890 15	180	10,7	114	221	3,13	1	-
2414 1990 15	200	11,9	126	249	4,34	1	-
2414 2090 15	225	13,4	135	269	5,80	1	-
2414 2190 15	250	14,8	148	307	7,62	1	-
2414 2290 15	280	16,6	156	332	10,2	1	-
2414 2390 15	315	18,7	170	359	13,9	1	-
2414 2490 15	355	21,1	170	410	22,7	1	-
2414 2590 15	400	23,7	187	469	30,7	1	-
2414 2690 15	450	26,7	202	522	43,4	1	-
2414 2790 15	500	29,7	222	562	60,1	1	-

## 2.01.01 Winkel lang • Elbows long

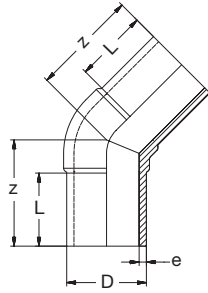

25.15.01.103 PE100 Winkel 45° lang **SDR11** schwarz  
PE100 Elbow 45° long **SDR11** black

Teil / Item	D [mm]	e [mm]	L [mm]	z [mm]	KG	VE1	VE2
2413 0745 15	25	2,3	35	41	0,020	10	150
2413 0845 15	32	3,0	40	48	0,034	5	80
2413 0945 15	40	3,7	44	58	0,076	5	50
2413 1045 15	50	4,6	54	74	0,12	5	90
2413 1145 15	63	5,8	70	82	0,23	5	40
2413 1245 15	75	6,9	76	98	0,31	2	20
2413 1345 15	90	8,2	84	120	0,58	2	10
2413 1445 15	110	10,0	89	130	0,92	2	8
2413 1545 15	125	11,4	100	145	1,25	2	6
2413 1645 15	140	12,7	104	154	1,72	1	3
2413 1745 15	160	14,6	111	168	2,60	1	3
2413 1845 15	180	16,4	118	185	3,56	1	-
2413 1945 15	200	18,2	127	202	4,68	1	-
2413 2045 15	225	20,5	135	216	5,52	1	-
2413 2145 15	250	22,7	141	233	8,92	1	-
2413 2245 15	280	25,4	145	242	11,4	1	-
2413 2345 15	315	28,6	165	265	15,4	1	-
2413 2445 15	355	32,2	170	317	23,5	1	-
2413 2545 15	400	36,6	187	346	30,0	1	-
2413 2645 15	450	40,9	202	375	44,0	1	-
2413 2745 15	500	45,4	222	410	57,0	1	-

25.15.01.063 PE100 Winkel 45° lang **SDR17** schwarz  
PE100 Elbow 45° long **SDR17** black

Teil / Item	D [mm]	e [mm]	L [mm]	z [mm]	KG	VE1	VE2
2414 1145 15	63	3,8	70	82	0,25	5	40
2414 1245 15	75	4,5	76	98	0,28	2	20
2414 1345 15	90	5,4	84	120	0,47	2	10
2414 1445 15	110	6,6	89	130	0,73	2	8
2414 1545 15	125	7,4	100	145	1,03	1	6
2414 1645 15	140	8,3	104	154	1,33	1	3
2414 1745 15	160	9,5	111	168	1,97	1	3
2414 1845 15	180	10,7	118	185	2,67	1	-
2414 1945 15	200	11,9	127	202	3,62	1	-
2414 2045 15	225	13,4	135	216	4,75	1	-
2414 2145 15	250	14,8	141	233	6,12	1	-
2414 2245 15	280	16,6	145	242	8,33	1	-
2414 2345 15	315	18,7	165	265	11,5	1	-
2414 2445 15	355	21,1	170	317	17,3	1	-
2414 2545 15	400	23,7	187	346	23,0	1	-
2414 2645 15	450	26,7	202	375	33,0	1	-
2414 2745 15	500	29,7	222	410	42,8	1	-

PE100

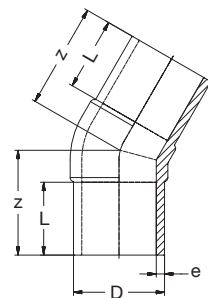

25.14.01.103 PE100 Winkel 30° lang **SDR11** schwarz  
PE100 Elbow 30° long **SDR11** black

Teil / Item	D [mm]	e [mm]	L [mm]	z [mm]	KG	VE1	VE2
2413 1230 15	75	6,9	77	103	0,34	2	20
2413 1330 15	90	8,2	85	110	0,55	2	14
2413 1430 15	110	10,0	95	130	0,93	2	8
2413 1530 15	125	11,4	100	142	1,25	1	4
2413 1630 15	140	12,7	103	144	1,60	1	3
2413 1730 15	160	14,6	116	155	2,38	1	3
2413 1830 15	180	16,4	120	165	3,01	1	-
2413 1930 15	200	18,2	125	175	4,01	1	-
2413 2030 15	225	20,5	133	188	5,50	1	-

25.14.01.063 PE100 Winkel 30° lang **SDR17** schwarz  
PE100 Elbow 30° long **SDR17** black

Teil / Item	D [mm]	e [mm]	L [mm]	z [mm]	KG	VE1	VE2
2414 1230 15	75	4,5	77	103	0,30	2	20
2414 1330 15	90	5,4	85	110	0,46	2	14
2414 1430 15	110	6,6	95	130	0,70	2	8
2414 1530 15	125	7,4	100	142	1,02	2	4
2414 1630 15	140	8,3	103	144	1,28	1	4
2414 1730 15	160	9,5	116	155	1,89	1	3
2414 1830 15	180	10,7	120	165	2,30	1	-
2414 1930 15	200	11,9	125	175	3,06	1	-
2414 2030 15	225	13,4	133	188	4,19	1	-

## 2.01.02 T-Stücke + Abzweige lang • Tee's + Branches long

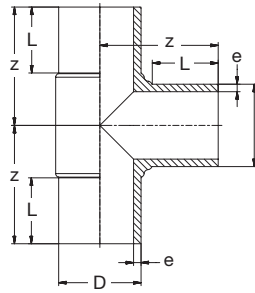

25.20.01.103 PE100 T-Stück 90° lang **SDR11** schwarz  
PE100 Tee 90° long **SDR11** black

Teil / Item	D [mm]	e [mm]	L [mm]	z [mm]	KG	VE1	VE2
2513 0790 15	25	2,3	41	62	0,034	5	150
2513 0890 15	32	3,0	51	75	0,065	5	80
2513 0990 15	40	3,7	55	82	0,12	5	60
2513 1090 15	50	4,6	61	95	0,18	5	40
2513 1190 15	63	5,8	67	114	0,39	5	20
2513 1290 15	75	6,9	73	121	0,55	2	10
2513 1390 15	90	8,2	82	153	1,00	2	8
2513 1490 15	110	10,0	98	172	1,62	1	6
2513 1590 15	125	11,4	102	180	2,05	1	3
2513 1690 15	140	12,7	105	195	2,90	1	2
2513 1790 15	160	14,6	124	225	4,30	1	-
2513 1890 15	180	16,4	117	233	5,69	1	-
2513 1990 15	200	18,2	127	253	7,72	1	-
2513 2090 15	225	20,5	136	275	10,7	1	-
2513 2190 15	250	22,7	140	298	13,0	1	-
2513 2290 15	280	25,4	150	325	18,9	1	-
2513 2390 15	315	28,6	160	350	27,0	1	-
2513 2490 15	355	32,2	173	390	36,4	1	-
2513 2590 15	400	36,3	187	431	52,6	1	-
2513 2690 15	450	40,9	202	476	70,2	1	-
2513 2790 15	500	45,4	225	525	90,3	1	-

25.20.01.063 PE100 T-Stück 90° lang **SDR17** schwarz  
PE100 Tee 90° long **SDR17** black

Teil / Item	D [mm]	e [mm]	L [mm]	z [mm]	KG	VE1	VE2
2514 1190 15	63	3,8	67	114	0,32	2	10
2514 1290 15	75	4,5	73	121	0,48	2	10
2514 1390 15	90	5,4	82	153	0,84	2	8
2514 1490 15	110	6,6	98	172	1,33	1	6
2514 1590 15	125	7,4	102	180	1,60	1	3
2514 1690 15	140	8,3	105	195	2,31	1	2
2514 1790 15	160	9,5	124	225	3,45	1	-
2514 1890 15	180	10,7	117	233	4,22	1	-
2514 1990 15	200	11,9	127	253	5,53	1	-
2514 2090 15	225	13,4	136	275	7,90	1	-
2514 2190 15	250	14,8	140	298	10,4	1	-
2514 2290 15	280	16,6	150	325	16,5	1	-
2514 2390 15	315	18,7	160	350	19,8	1	-
2514 2490 15	355	21,1	173	390	24,7	1	-
2514 2590 15	400	23,7	187	431	41,9	1	-
2514 2690 15	450	26,7	202	476	51,4	1	-
2514 2790 15	500	29,7	225	525	64,9	1	-

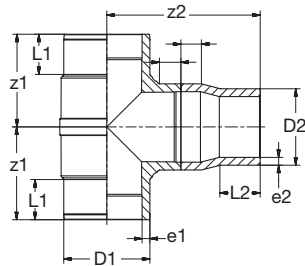

25.20.01.103 PE100 T-Stück 90° red lang Form-B **SDR11** schwarz  
PE100 Tee 90° red long form-B **SDR11** black

Teil / Item	D1-D2 [mm]	e1 [mm]	e2 [mm]	L1 [mm]	L2 [mm]	z1 [mm]	z2 [mm]	KG	VE1	VE2
2523 2421 15	355-250	32,2	22,7	172	143	390	661	42,2	1	-
2523 2422 15	355-280	32,2	25,4	172	148	390	661	42,9	1	-
2523 2423 15	355-315	32,2	28,6	172	158	390	661	43,8	1	-
2523 2522 15	400-280	36,3	25,4	187	153	431	707	56,5	1	-
2523 2523 15	400-315	36,3	28,6	187	158	431	707	57,4	1	-
2523 2524 15	400-355	36,3	32,2	187	168	431	707	58,6	1	-
2523 2724 15	500-355	45,4	32,2	222	172	522	798	102,1	1	-
2523 2725 15	500-400	45,4	36,3	222	187	522	798	103,7	1	-
2523 2726 15	500-450	45,4	40,9	222	202	522	798	106,0	1	-

25.20.01.063 PE100 T-Stück 90° red lang Form-B **SDR17** schwarz  
PE100 Tee 90° red long form-B **SDR17** black

Teil / Item	D1-D2 [mm]	e1 [mm]	e2 [mm]	L1 [mm]	L2 [mm]	z1 [mm]	z2 [mm]	KG	VE1	VE2
2524 2421 15	355-250	21,2	14,8	172	143	390	661	30,1	1	-
2524 2422 15	355-280	21,1	16,6	172	148	390	661	30,6	1	-
2524 2423 15	355-315	21,1	18,7	172	158	390	661	31,2	1	-
2524 2522 15	400-280	23,7	16,6	187	153	431	707	39,7	1	-
2524 2523 15	400-315	23,7	18,7	187	158	431	707	40,3	1	-
2524 2524 15	400-355	23,7	21,1	187	168	431	707	41,2	1	-
2524 2724 15	500-355	29,7	21,1	222	172	522	798	71,5	1	-
2524 2725 15	500-400	29,7	23,7	222	187	522	798	72,6	1	-
2524 2726 15	500-450	29,7	26,7	222	202	522	798	74,1	1	-

Form B = T-Stück egal mit angeschweißter Reduktion.  
Form B = Tee equal with welded Reducer.

## 2.01.02 T-Stücke + Abzweige lang • Tee's + Branches long

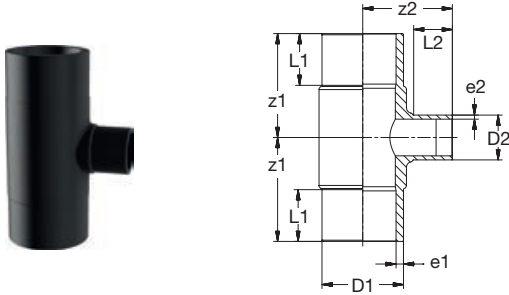

25.20.01.103 PE100 T-Stück 90° red lang **SDR11** schwarz  
PE100 Tee 90° red long **SDR11** black

Teil / Item	D1-D2 [mm]	e1 [mm]	e2 [mm]	L1 [mm]	L2 [mm]	z1 [mm]	z2 [mm]	KG	VE1	VE2
2523 1108 15	<b>63-32</b>	5,8	3,0	70	46	114	91	0,32	2	16
2523 1411 15	<b>110-63</b>	10,0	5,8	93	65	158	139	1,30	1	5
2523 1413 15	<b>110-90</b>	10,0	8,2	91	83	160	158	1,40	1	4
2523 1511 15	<b>125-63</b>	11,4	5,8	101	70	179	157	1,69	1	4
2523 1512 15	<b>125-75</b>	11,4	6,9	102	76	179	162	1,72	1	4
2523 1513 15	<b>125-90</b>	11,4	8,2	100	86	179	170	1,80	1	4
2523 1514 15	<b>125-110</b>	11,4	10,0	101	96	179	179	1,93	1	4
2523 1611 15	<b>140-63</b>	12,7	5,8	103	69	193	165	2,41	1	3
2523 1612 15	<b>140-75</b>	12,7	6,9	104	77	193	177	2,45	1	3
2523 1612 15	<b>140-90</b>	12,7	8,2	105	85	193	188	2,51	1	3
2523 1614 15	<b>140-110</b>	12,7	10,0	105	88	193	188	2,64	1	2
2523 1711 15	<b>160-63</b>	14,6	5,8	110	72	212	179	3,55	1	2
2523 1712 15	<b>160-75</b>	14,6	6,9	110	71	212	178	3,49	1	2
2523 1713 15	<b>160-90</b>	14,6	8,2	110	85	212	196	3,65	1	2
2523 1714 15	<b>160-110</b>	14,6	10,0	110	93	212	201	3,77	1	-
2523 1812 15	<b>180-75</b>	16,4	6,9	116	77	230	197	4,95	1	2
2523 1813 15	<b>180-90</b>	16,4	8,2	117	85	230	208	4,97	1	-
2523 1814 15	<b>180-110</b>	16,4	10,0	117	98	230	218	4,98	1	-
2523 1815 15	<b>180-125</b>	16,4	11,4	117	100	230	223	5,11	1	-
2523 1816 15	<b>180-140</b>	16,4	12,7	116	105	230	225	5,54	1	-
2523 1817 15	<b>180-160</b>	16,4	14,6	116	112	230	232	5,60	1	-
2523 1911 15	<b>200-63</b>	18,2	5,8	127	72	255	195	6,39	1	-
2523 1912 15	<b>200-75</b>	18,2	6,9	127	80	255	203	6,44	1	-
2523 1913 15	<b>200-90</b>	18,2	8,2	127	87	255	212	6,52	1	-
2523 1914 15	<b>200-110</b>	18,2	10,0	127	97	255	224	6,64	1	-
2523 1915 15	<b>200-125</b>	18,2	11,4	127	104	255	225	6,75	1	-
2523 1917 15	<b>200-160</b>	18,2	14,6	127	112	255	242	7,08	1	-
2523 2011 15	<b>225-63</b>	20,5	5,8	130	68	270	245	8,31	1	-
2523 2012 15	<b>225-75</b>	20,5	6,9	130	75	270	251	8,33	1	-
2523 2013 15	<b>225-90</b>	20,5	8,2	130	87	270	264	8,40	1	-
2523 2014 15	<b>225-110</b>	20,5	10,0	128	92	261	268	8,62	1	-
2523 2015 15	<b>225-125</b>	20,5	11,4	130	92	261	267	8,72	1	-
2523 2016 15	<b>225-140</b>	20,5	12,7	130	105	270	280	8,88	1	-
2523 2017 15	<b>225-160</b>	20,5	14,6	120	110	261	248	8,92	1	-
2523 2113 15	<b>250-90</b>	22,7	8,2	145	85	298	235	10,30	1	-
2523 2114 15	<b>250-110</b>	22,7	10,0	145	100	298	265	10,3	1	-
2523 2115 15	<b>250-125*</b>	22,7	11,4	145	115	298	270	10,7	1	-
2523 2117 15	<b>250-160*</b>	22,7	14,6	145	118	298	275	10,7	1	-
2523 2214 15	<b>280-110*</b>	25,4	10,0	146	95	321	260	14,0	1	-
2523 2217 15	<b>280-160*</b>	25,4	14,6	146	110	321	280	14,4	1	-
2523 2314 15	<b>315-110*</b>	28,6	10,0	165	100	352	291	19,2	1	-
2523 2317 15	<b>315-160*</b>	28,6	14,6	165	110	352	305	19,4	1	-
2523 2321 15	<b>315-250*</b>	28,6	22,7	165	137	352	328	20,8	1	-

\* In Vorbereitung • Under preparation.

25.20.01.063 PE100 T-Stück 90° red lang **SDR17** schwarz  
PE100 Tee red 90° long **SDR17** black

Teil / Item	D1-D2 [mm]	e1 [mm]	e2 [mm]	L1 [mm]	L2 [mm]	z1 [mm]	z2 [mm]	KG	VE1	VE2
2524 1108 15	<b>63-32</b>	3,8	3,0**	70	46	114	91	0,28	2	16
2524 1411 15	<b>110-63</b>	6,6	5,8**	93	65	158	139	1,11	1	5
2524 1413 15	<b>110-90</b>	6,6	5,4	91	83	160	158	1,18	1	4
2524 1511 15	<b>125-63</b>	7,4	5,8**	101	70	179	157	1,13	1	4
2524 1512 15	<b>125-75</b>	7,4	4,5	102	76	179	162	1,37	1	4
2524 1513 15	<b>125-90</b>	7,4	5,4	100	86	179	170	1,41	1	4
2524 1514 15	<b>125-110</b>	7,4	6,6	101	96	179	179	1,51	1	4
2524 1611 15	<b>140-63</b>	8,3	5,8**	103	69	193	165	1,94	1	3
2524 1612 15	<b>140-75</b>	8,3	4,5	104	77	193	177	1,99	1	3
2524 1612 15	<b>140-90</b>	8,3	5,4	105	85	193	188	2,01	1	3
2524 1614 15	<b>140-110</b>	8,3	6,6	105	88	193	188	2,09	1	2
2524 1711 15	<b>160-63</b>	9,5	5,8**	110	72	212	179	2,87	1	2
2524 1712 15	<b>160-75</b>	9,5	4,5	110	71	212	178	2,88	1	2
2524 1713 15	<b>160-90</b>	9,5	5,4	110	85	212	196	2,92	1	2
2524 1714 15	<b>160-110</b>	9,5	6,6	110	93	212	201	3,00	1	-
2524 1812 15	<b>180-75</b>	10,7	4,5	116	77	230	197	3,92	1	2
2524 1813 15	<b>180-90</b>	10,7	5,4	117	85	230	208	3,95	1	-
2524 1814 15	<b>180-110</b>	10,7	6,6	117	98	230	218	4,03	1	-
2524 1815 15	<b>180-125</b>	10,7	7,4	117	100	230	223	4,10	1	-
2524 1816 15	<b>180-140</b>	10,7	8,3	116	105	230	225	4,19	1	-
2524 1817 15	<b>180-160</b>	10,7	9,5	116	112	230	232	4,44	1	-
2524 1911 15	<b>200-63</b>	11,9	5,8**	127	72	255	195	5,13	1	-
2524 1912 15	<b>200-75</b>	11,9	4,5	127	80	255	203	5,15	1	-
2524 1913 15	<b>200-90</b>	11,9	5,4	127	87	255	212	5,22	1	-
2524 1914 15	<b>200-110</b>	11,9	6,6	127	97	255	224	5,25	1	-
2524 1915 15	<b>200-125</b>	11,9	7,4	127	104	255	225	5,38	1	-
2524 1917 15	<b>200-160</b>	11,9	9,5	127	112	255	242	5,65	1	-
2524 2011 15	<b>225-63</b>	13,4	5,8**	130	68	270	245	6,69	1	-
2524 2012 15	<b>225-75</b>	13,4	4,5	130	75	270	251	6,71	1	-
2524 2013 15	<b>225-90</b>	13,4	5,4	130	87	270	264	6,77	1	-
2524 2014 15	<b>225-110</b>	13,4	6,6	128	92	261	268	6,97	1	-
2524 2015 15	<b>225-125</b>	13,4	7,4	130	92	261	267	6,98	1	-
2524 2016 15	<b>225-140</b>	13,4	8,3	130	105	270	280	7,17	1	-
2524 2017 15	<b>225-160</b>	13,4	9,5	120	110	261	248	7,20	1	-
2524 2113 15	<b>250-90*</b>	14,8	5,4	145	85	298	235	7,30	1	-
2524 2114 15	<b>250-110*</b>	14,8	6,6	145	95	298	265	7,30	1	-
2524 2115 15	<b>250-125*</b>	14,8	7,4	145	115	298	270	7,60	1	-
2524 2117 15	<b>250-160*</b>	14,8	9,5	145	100	298	275	7,60	1	-
2524 2214 15	<b>280-110*</b>	16,6	6,6	146	95	321	260	9,90	1	-
2524 2217 15	<b>280-160*</b>	16,6	9,5	146	118	321	280	10,1	1	-
2524 2314 15	<b>315-110*</b>	18,7	6,6	165	100	352	291	13,6	1	-
2524 2317 15	<b>315-160*</b>	18,7	9,5	165	110	352	305	14,6	1	-
2524 2321 15	<b>315-250*</b>	18,7	14,8	165	137	352	328	15,2	1	-

\*\* SDR 11

\* In Vorbereitung • Under preparation.

## 2.01.02 T-Stücke + Abzweige lang • Tee's + Branches long

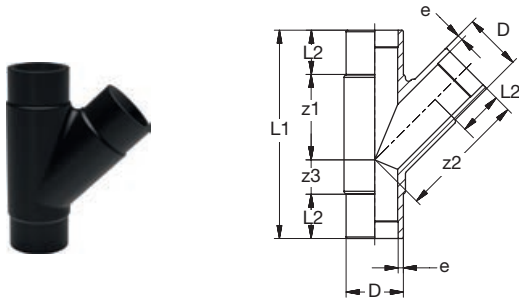

25.25.01.103 PE100 Abzweig 45° lang **SDR11** schwarz  
PE100 Branch 45° long **SDR11** black

Teil / Item	D [mm]	e [mm]	L1 [mm]	L2 [mm]	z1 [mm]	z2 [mm]	z3 [mm]	KG	VE1	VE2
2513 0945 15	40	3,7	189	45	75	75	20	0,16	2	40
2513 1045 15	50	4,6	222	55	90	90	23	0,29	2	28
2513 1145 15	63	5,8	244	63	96	93	23	0,47	2	16
2513 1245 15	75	6,9	290	75	105	107	34	0,55	2	10
2513 1345 15	90	8,2	371	85	149	149	51	1,45	1	5
2513 1445 15	110	10,0	400	85	164	164	55	2,24	1	3
2513 1545 15	125	11,4	447	105	185	185	45	3,31	1	2
2513 1745 15	160	14,6	538	115	260	260	50	6,26	1	-
2513 1845 15	180	16,4	580	116	268	272	75	8,65	1	-
2513 1945 15	200	18,2	633	122	287	286	94	11,7	1	-
2513 2045 15	225	20,5	700	135	350	350	85	16,3	1	-
2513 2145 15	250	22,7	792	143	397	397	109	22,5	1	-
2513 2245 15	280*	25,4	852	146	440	440	120	31,1	1	-
2513 2345 15	315	28,6	965	165	497	497	138	44,4	1	-

\* In Vorbereitung • Under preparation.

25.25.01.063 PE100 Abzweig 45° lang **SDR17** schwarz  
PE100 Branch 45° long **SDR17** black

Teil / Item	D [mm]	e [mm]	L1 [mm]	L2 [mm]	z1 [mm]	z2 [mm]	z3 [mm]	KG	VE1	VE2
2514 0945 15	40	2,4	189	45	75	75	20	0,14	2	40
2514 1045 15	50	3,0	222	55	90	90	23	0,23	2	28
2514 1145 15	63	3,8	244	63	96	93	23	0,44	2	16
2514 1245 15	75	4,5	290	75	105	107	34	0,59	2	12
2514 1345 15	90	5,4	371	85	149	149	51	1,25	1	5
2514 1445 15	110	6,6	400	85	164	164	55	1,50	1	3
2514 1545 15	125	7,4	447	105	185	185	45	2,86	1	2
2514 1745 15	160	9,5	538	115	260	260	50	5,62	1	-
2514 1845 15	180	10,7	580	116	268	272	75	7,75	1	-
2514 1945 15	200	11,9	633	122	287	286	94	10,2	1	-
2514 2045 15	225	13,4	700	135	350	350	85	14,8	1	-
2514 2145 15	250	14,8	792	143	397	397	109	16,9	1	-
2514 2245 15	280*	16,6	852	146	440	440	120	23,4	1	-
2514 2345 15	315	18,7	965	165	494	494	138	33,4	1	-

\* In Vorbereitung • Under preparation.

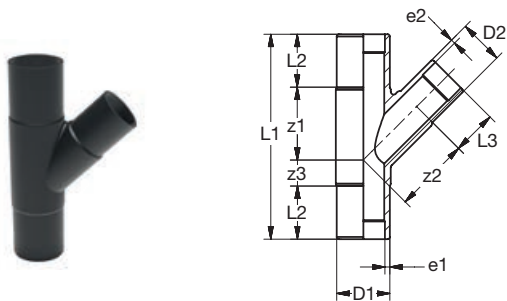

25.25.01.063 PE100 Abzweig 45° red lang **SDR17** schwarz  
PE100 Branch 45° red long **SDR17** black

Teil / Item	D1-D2 [mm]	e1 [mm]	e2 [mm]	L1 [mm]	L2 [mm]	L3 [mm]	z1 [mm]	z2 [mm]	z3 [mm]	KG	VE1	VE2
2534 1211 15	75-63	4,5	5,8*	290	75	63	102	102	37	0,58	2	12

\* SDR11

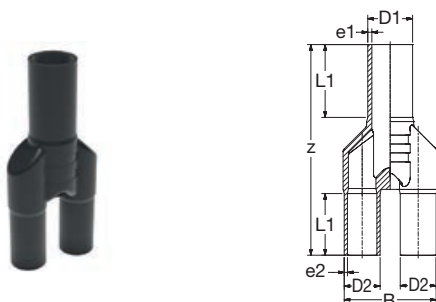

52603 PE100 Hosenstück lang **SDR11** schwarz  
PE100 Y-piece long **SDR11** black

Teil / Item	D1-D2 [mm]	e1 [mm]	e2 [mm]	L1 [mm]	L2 [mm]	z [mm]	B [mm]	KG	VE1	VE2
2543 0908 15	40-32	3,7	2,9	65	55	188	82	0,11	1	
2543 1009 15	50-40	4,6	3,7	75	65	228	101	0,22	1	

## 2.01.03 Reduktionen + Kappen lang • Reducers + Caps long

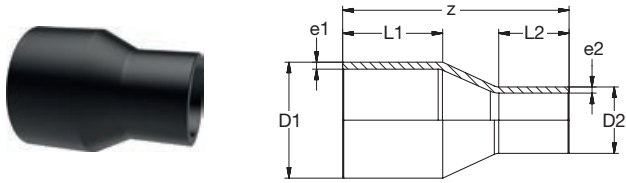

25.91.03.103 PE100 Reduktion lang **SDR11** schwarz  
PE100 Reducer long **SDR11** black

Teil / Item	D1-D2 [mm]	e1 [mm]	e2 [mm]	L1 [mm]	L2 [mm]	z [mm]	KG	VE1	VE2
2323 0807 15	<b>32-25</b>	3,0	2,3	44	37	89	0,020	10	60
2323 0906 35	<b>40-20</b>	3,7	1,9	45	36	94	0,030	10	40
2323 0907 15	<b>40-25</b>	3,7	2,3	47	35	96	0,032	10	30
2323 0908 15	<b>40-32</b>	3,7	2,9	50	39	93	0,036	10	30
2323 1007 15	<b>50-25</b>	4,6	2,3	62	48	136	0,060	10	120
2323 1008 15	<b>50-32</b>	4,6	2,9	61	50	134	0,066	10	110
2323 1009 15	<b>50-40</b>	4,6	3,7	61	56	134	0,075	10	110
2323 1107 35	<b>63-25</b>	5,8	2,3	64	57	140	0,090	5	60
2323 1108 15	<b>63-32</b>	5,8	2,9	69	50	150	0,11	5	60
2323 1109 15	<b>63-40</b>	5,8	3,7	69	55	152	0,12	5	50
2323 1110 15	<b>63-50</b>	5,8	4,6	69	60	151	0,14	5	50
2323 1209 15	<b>75-40</b>	6,9	3,7	76	55	172	0,20	4	48
2323 1210 15	<b>75-50</b>	6,9	4,6	76	61	172	0,14	4	40
2323 1211 15	<b>75-63</b>	6,9	5,8	76	69	172	0,22	4	40
2323 1310 15	<b>90-50</b>	8,2	4,6	85	60	175	0,27	2	36
2323 1311 15	<b>90-63</b>	8,2	5,8	85	71	178	0,30	2	36
2323 1312 15	<b>90-75</b>	8,2	6,9	85	80	181	0,34	2	36
2323 1410 35	<b>110-50</b>	10,0	4,6	88	57	177	0,39	2	14
2323 1411 15	<b>110-63</b>	10,0	5,8	95	70	212	0,49	2	14
2323 1412 15	<b>110-75</b>	10,0	6,9	95	79	215	0,49	2	14
2323 1413 15	<b>110-90</b>	10,0	8,2	95	88	215	0,58	2	12
2323 1511 15	<b>125-63</b>	11,4	5,8	99	66	226	0,63	1	12
2323 1512 15	<b>125-75</b>	11,4	6,9	100	75	227	0,67	1	12
2323 1513 15	<b>125-90</b>	11,4	8,2	100	74	225	0,72	1	9
2323 1514 15	<b>125-110</b>	11,4	10,0	100	80	228	0,82	1	9
2323 1612 15	<b>140-75</b>	12,7	6,9	116	72	246	0,85	1	9
2323 1613 15	<b>140-90</b>	12,7	8,2	116	85	248	0,92	1	9
2323 1614 15	<b>140-110</b>	12,7	10,0	105	95	250	1,04	1	7
2323 1615 15	<b>140-125</b>	12,7	11,4	105	105	253	1,17	1	7
2323 1713 15	<b>160-90</b>	14,6	8,2	111	84	260	1,20	1	8
2323 1714 15	<b>160-110</b>	14,6	10,0	112	94	260	1,34	1	8
2323 1715 15	<b>160-125</b>	14,6	11,4	111	98	260	1,42	1	8
2323 1716 15	<b>160-140</b>	14,6	12,7	111	105	260	1,57	1	7
2323 1813 35	<b>180-90</b>	16,4	8,2	110	90	260	1,41	1	6
2323 1814 15	<b>180-110</b>	16,4	10,0	115	95	275	1,60	1	6
2323 1815 15	<b>180-125</b>	16,4	11,4	116	105	275	1,77	1	6
2323 1816 35	<b>180-140</b>	16,4	12,7	105	96	221	1,61	1	4
2323 1817 15	<b>180-160</b>	16,4	14,6	117	110	275	2,07	1	4
2323 1914 35	<b>200-110</b>	18,2	10,0	126	96	287	1,90	1	2
2323 1915 15	<b>200-125</b>	18,2	11,4	124	110	281	2,21	1	2
2323 1917 15	<b>200-160</b>	18,2	14,6	124	110	278	2,44	1	2
2323 1918 35	<b>200-180</b>	18,2	16,4	117	109	236	2,30	1	2
2323 2013 35	<b>225-90</b>	20,5	8,2	130	90	300	2,52	1	2
2323 2014 15	<b>225-110</b>	20,5	10,0	132	90	311	2,91	1	2
2323 2015 35	<b>225-125</b>	20,5	11,4	130	100	310	2,81	1	2
2323 2017 15	<b>225-160</b>	20,5	14,6	132	110	310	3,02	1	2
2323 2018 15	<b>225-180</b>	20,5	16,4	140	115	310	3,50	1	-
2323 2019 35	<b>225-200</b>	20,5	18,2	132	130	277	3,47	1	-

Teil / Item	D1-D2 [mm]	e1 [mm]	e2 [mm]	L1 [mm]	L2 [mm]	z [mm]	KG	VE1	VE2
2323 2117 15	<b>250-160</b>	22,7	14,6	140	110	338	4,15	1	-
2323 2118 15	<b>250-180</b>	22,7	16,4	140	120	338	4,32	1	-
2323 2119 15	<b>250-200</b>	22,7	18,2	140	125	335	4,65	1	-
2323 2120 15	<b>250-225</b>	22,7	20,5	140	125	335	5,09	1	-
2323 2218 15	<b>280-180</b>	25,4	16,4	150	120	357	5,49	1	-
2323 2219 15	<b>280-200</b>	25,4	18,2	150	125	357	5,81	1	-
2323 2220 15	<b>280-225</b>	25,4	20,5	150	132	357	6,16	1	-
2323 2221 15	<b>280-250</b>	25,4	22,7	150	145	355	6,70	1	-
2323 2320 15	<b>315-225</b>	28,6	20,5	160	142	392	7,78	1	-
2323 2321 15	<b>315-250</b>	28,6	22,7	160	145	392	8,33	1	-
2323 2322 15	<b>315-280</b>	28,6	25,4	160	157	392	9,09	1	-
2323 2421 15	<b>355-250</b>	32,2	22,7	175	145	426	10,9	1	-
2323 2422 15	<b>355-280</b>	32,2	25,4	170	155	426	11,7	1	-
2323 2423 15	<b>355-315</b>	32,2	28,6	175	170	426	12,7	1	-
2323 2522 15	<b>400-280</b>	36,3	25,4	190	155	465	14,8	1	-
2323 2523 15	<b>400-315</b>	36,3	28,6	190	165	460	15,6	1	-
2323 2524 15	<b>400-355</b>	36,3	32,2	190	185	463	17,0	1	-
2323 2622 15	<b>450-280</b>	40,9	25,4	202	146	480	18,4	1	-
2323 2623 15	<b>450-315</b>	40,9	28,6	202	157	480	19,5	1	-
2323 2624 15	<b>450-355</b>	40,9	32,2	202	172	480	20,9	1	-
2323 2625 15	<b>450-400</b>	40,9	36,3	202	187	480	22,8	1	-
2323 2724 15	<b>500-355</b>	45,4	32,2	222	172	520	28,5	1	-
2323 2725 15	<b>500-400</b>	45,4	36,3	222	187	520	29,0	1	-
2323 2726 15	<b>500-450</b>	45,4	40,9	222	202	520	32,5	1	-
2323 2924 15	<b>630-355</b>	57,2	32,2	265	172	650	49,3	1	-
2323 2925 15	<b>630-400</b>	57,2	36,3	265	187	650	51,0	1	-
2323 2926 15	<b>630-450</b>	57,2	40,9	265	202	650	53,7	1	-
2323 2927 15	<b>630-500</b>	57,2	45,4	265	222	650	56,6	1	-

## 2.01.03 Reduktionen + Kappen lang • Reducers + Caps long

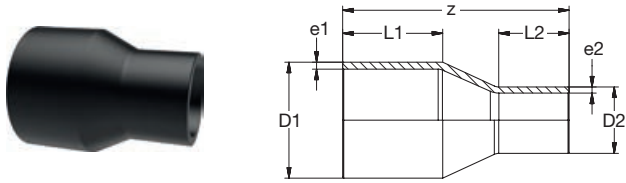

25.91.03.063 PE100 Reduktion lang **SDR17** schwarz  
PE100 Reducer long **SDR17** black

Teil / Item	D1-D2 [mm]	e1 [mm]	e2 [mm]	L1 [mm]	L2 [mm]	z [mm]	KG	VE1	VE2
2324 1209 15	<b>75-40</b>	4,5	3,7*	76	55	172	0,16	4	48
2324 1210 15	<b>75-50</b>	4,5	4,6*	76	61	172	0,17	4	40
2324 1211 15	<b>75-63</b>	4,5	5,8*	76	69	172	0,18	4	36
2324 1310 15	<b>90-50</b>	5,4	4,6*	85	60	175	0,20	1	40
2324 1311 15	<b>90-63</b>	5,4	5,8*	85	71	178	0,24	1	40
2324 1312 15	<b>90-75</b>	5,4	4,5	85	80	181	0,23	1	40
2324 1410 35	<b>110-50</b>	6,6	3,0	88	57	177	0,27	1	14
2324 1411 15	<b>110-63</b>	6,6	5,8*	95	70	212	0,36	2	14
2324 1412 15	<b>110-75</b>	6,6	4,5	95	79	215	0,35	2	14
2324 1413 15	<b>110-90</b>	6,6	5,4	95	88	215	0,38	2	14
2324 1511 15	<b>125-63</b>	7,4	5,8*	99	66	226	0,46	1	12
2324 1512 15	<b>125-75</b>	7,4	4,5	100	75	227	0,45	1	12
2324 1513 15	<b>125-90</b>	7,4	5,4	100	74	225	0,48	1	12
2324 1514 15	<b>125-110</b>	7,4	6,6	100	80	228	0,57	1	9
2324 1612 15	<b>140-75</b>	8,3	4,5	116	72	246	0,61	1	10
2324 1613 15	<b>140-90</b>	8,3	5,4	116	85	248	0,64	1	11
2324 1614 15	<b>140-110</b>	8,3	6,6	105	95	250	0,72	1	8
2324 1615 15	<b>140-125</b>	8,3	7,4	105	105	253	0,79	1	8
2324 1713 15	<b>160-90</b>	9,5	5,4	111	84	260	0,84	1	8
2324 1714 15	<b>160-110</b>	9,5	6,6	112	94	260	0,91	1	8
2324 1715 15	<b>160-125</b>	9,5	7,4	111	98	260	0,95	1	8
2324 1716 15	<b>160-140</b>	9,5	8,3	111	105	260	1,03	1	7
2324 1813 35	<b>180-90</b>	10,7	5,4	110	90	260	0,98	1	6
2324 1814 15	<b>180-110</b>	10,7	6,6	115	95	275	1,09	1	6
2324 1815 15	<b>180-125</b>	10,7	7,4	116	105	275	1,20	1	6
2324 1816 35	<b>180-140</b>	10,7	8,3	105	96	221	1,05	1	4
2324 1817 15	<b>180-160</b>	10,7	9,5	117	110	275	1,83	1	4
2324 1914 35	<b>200-110</b>	11,9	6,6	126	96	287	1,30	1	2
2324 1915 15	<b>200-125</b>	11,9	7,4	124	110	281	1,97	1	2
2324 1917 15	<b>200-160</b>	11,9	9,5	124	110	278	1,70	1	2
2324 1918 35	<b>200-180</b>	11,9	10,7	117	109	236	1,20	1	2
2324 2013 35	<b>225-90</b>	13,4	5,4	121	89	298	1,80	1	-
2324 2014 15	<b>225-110</b>	13,4	6,6	132	90	311	2,62	1	-
2324 2015 35	<b>225-125</b>	13,4	7,4	131	100	288	1,90	1	-
2324 2017 15	<b>225-160</b>	13,4	9,5	132	110	310	2,22	1	2
2324 2018 15	<b>225-180</b>	13,4	10,7	140	115	310	2,37	1	-
2324 2019 35	<b>225-200</b>	13,4	11,9	140	130	277	2,38	1	-
2324 2117 15	<b>250-160</b>	14,8	9,5	140	110	338	3,64	1	-
2324 2118 15	<b>250-180</b>	14,8	10,7	140	120	338	3,79	1	-
2324 2119 15	<b>250-200</b>	14,8	11,9	140	125	335	4,00	1	-
2324 2120 15	<b>250-225</b>	14,8	13,4	140	125	335	4,45	1	-
2324 2218 15	<b>280-180</b>	16,6	10,7	150	120	357	4,77	1	-
2324 2219 15	<b>280-200</b>	16,6	11,9	150	125	357	5,00	1	-
2324 2220 15	<b>280-225</b>	16,6	13,4	150	132	357	5,35	1	-
2324 2221 15	<b>280-250</b>	16,6	14,8	150	145	355	5,93	1	-
2324 2320 15	<b>315-225</b>	18,7	13,4	160	142	392	6,92	1	-
2324 2321 15	<b>315-250</b>	18,7	14,8	160	145	392	7,38	1	-
2324 2322 15	<b>315-280</b>	18,7	16,6	160	157	392	7,92	1	-

\* SDR 11

Teil / Item	D1-D2 [mm]	e1 [mm]	e2 [mm]	L1 [mm]	L2 [mm]	z [mm]	KG	VE1	VE2
2324 2421 15	<b>355-250</b>	21,1	14,8	175	145	426	9,60	1	-
2324 2422 15	<b>355-280</b>	21,1	16,6	170	155	426	10,2	1	-
2324 2423 15	<b>355-315</b>	21,1	18,7	175	170	426	11,1	1	-
2324 2522 15	<b>400-280</b>	23,7	16,6	190	155	465	13,2	1	-
2324 2523 15	<b>400-315</b>	23,7	18,7	190	165	460	13,9	1	-
2324 2524 15	<b>400-355</b>	23,7	21,1	190	185	463	15,0	1	-
2324 2622 15	<b>450-280</b>	26,7	16,6	202	146	480	12,5	1	-
2324 2623 15	<b>450-315</b>	26,7	18,7	202	157	480	13,3	1	-
2324 2624 15	<b>450-355</b>	26,7	21,1	202	172	480	14,2	1	-
2324 2625 15	<b>450-400</b>	26,7	23,7	202	187	480	15,5	1	-
2324 2724 15	<b>500-355</b>	29,7	21,1	222	172	520	18,4	1	-
2324 2725 15	<b>500-400</b>	29,7	23,7	222	187	520	19,5	1	-
2324 2726 15	<b>500-450</b>	29,7	26,7	222	202	520	21,2	1	-
2324 2924 15	<b>630-355</b>	37,4	21,1	265	172	650	33,5	1	-
2324 2925 15	<b>630-400</b>	37,4	23,7	265	187	650	34,8	1	-
2324 2926 15	<b>630-450</b>	37,4	26,7	265	202	650	36,5	1	-
2324 2927 15	<b>630-500</b>	37,4	29,7	265	222	650	38,5	1	-

\* SDR 11

## 2.01.03 Reduktionen + Kappen lang • Reducers + Caps long

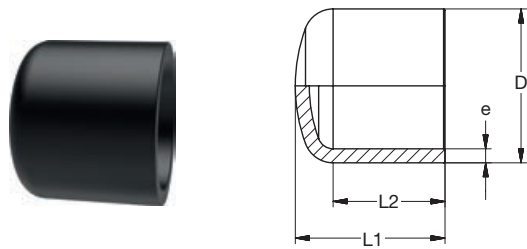

25.96.01.103 PE100 Kappe lang **SDR11** schwarz  
PE100 Cap long **SDR11** black

Teil / Item	D [mm]	e [mm]	L1 [mm]	L2 [mm]	KG	VE1	VE2
2443 0700 15	25	2,3	52	46	0,010	10	150
2443 0800 15	32	3,0	57	48	0,017	10	90
2443 0900 15	40	3,7	68	56	0,030	10	240
2443 1000 15	50	4,6	74	58	0,053	10	140
2443 1100 15	63	5,8	80	66	0,085	5	60
2443 1200 15	75	6,8	80	67	0,14	2	70
2443 1300 15	90	8,2	91	73	0,22	2	40
2443 1400 15	110	10,0	107	82	0,38	2	24
2443 1500 15	125	11,4	125	94	0,55	2	18
2443 1600 15	140	12,7	138	110	0,79	2	12
2443 1700 15	160	14,6	152	120	1,12	2	8
2443 1800 15	180	16,4	168	132	1,59	1	2
2443 1900 15	200	18,2	184	143	2,16	1	2
2443 2000 15	225	20,5	202	163	2,96	1	2
2443 2100 15	250	22,7	218	170	3,29	1	-
2443 2200 15	280	25,4	227	182	4,80	1	-
2443 2300 15	315	28,6	245	190	6,28	1	-
2443 2400 15	355	32,2	264	213	9,09	1	-
2443 2500 15	400	36,3	280	230	12,5	1	-
2443 2600 15	450	40,9	306	195	17,0	1	-
2443 2700 15	500	45,4	335	212	22,9	1	-
2443 2900 15	630	57,2	410	255	44,7	1	-

25.96.01.063 PE100 Kappe lang **SDR17** schwarz  
PE100 Cap long **SDR17** black

Teil / Item	D [mm]	e [mm]	L1 [mm]	L2 [mm]	KG	VE1	VE2
2444 1100 15	63	3,8	80	66	0,060	1	40
2444 1200 15	75	4,5	80	67	0,090	2	70
2444 1300 15	90	5,4	91	73	0,15	2	40
2444 1400 15	110	6,6	107	82	0,26	2	24
2444 1500 15	125	7,4	125	94	0,39	2	18
2444 1600 15	140	8,3	138	110	0,54	2	12
2444 1700 15	160	9,5	152	120	0,78	2	8
2444 1800 15	180	10,7	168	132	1,08	1	2
2444 1900 15	200	11,9	184	143	1,49	1	2
2444 2000 15	225	13,4	202	163	2,05	1	2
2444 2100 15	250	14,8	218	170	2,90	1	-
2444 2200 15	280	16,6	227	182	3,86	1	-
2444 2300 15	315	18,7	245	190	4,62	1	-
2444 2400 15	355	21,1	264	213	6,29	1	-
2444 2500 15	400	23,7	280	230	8,43	1	-
2444 2600 15	450	26,7	306	195	11,8	1	-
2444 2700 15	500	29,7	335	212	15,9	1	-
2444 2900 15	630	37,4	410	255	31,0	1	-

## 2.01.04 Übergänge lang • Transitions long

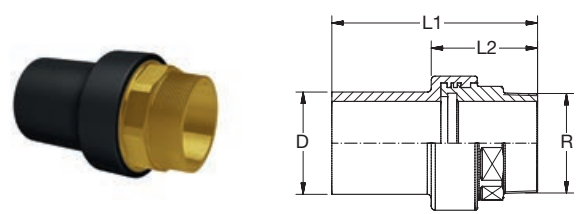
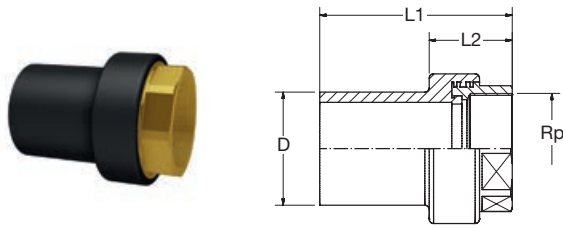

39203 PE100-Messing Übergang lang IG-zyl **SDR11** schwarz  
PE100-Brass Transition long female-thread-cyl **SDR11** black

Teil / Item	D x Rp [mm x Inch]	Thread	e [mm]	L1 [mm]	L2 [mm]	KG	VE1	VE2
2M13 0643 35	20 x 1/2	f	3,0	84	40	0,17	1	50
2M13 0745 35	25 x 3/4	f	3,0	85	42	0,18	1	32
2M13 0846 35	32 x 1	f	3,0	90	43	0,28	1	30
2M13 0947 35	40 x 1 1/4	f	3,7	100	47	0,38	1	15
2M13 1048 35	50 x 1 1/2	f	4,6	108	47	0,51	1	10
2M13 1150 35	63 x 2	f	5,8	122	53	0,74	1	9
2M13 1253 35	75 x 2 1/2	f	6,8	138	62	0,77	1	9
2M13 1355 35	90 x 3	f	8,2	153	66	1,66	1	4
2M13 1457 35	110 x 4	f	10,0	167	80	2,56	1	2
2M13 1557 35	125 x 4	f	11,4	177	82	3,40	1	-

39703 PE100-Messing Übergang lang AG-keg **SDR11** schwarz  
PE100-Brass Transition long male-thread-con **SDR11** black

Teil / Item	D x R [mm x Inch]	Thread	e [mm]	L1 [mm]	L2 [mm]	KG	VE1	VE2
2M13 0673 35	20 x 1/2	m	3,0	100	56	0,22	1	40
2M13 0775 35	25 x 3/4	m	3,0	103	59	0,24	1	40
2M13 0876 35	32 x 1	m	3,0	110	62	0,35	1	25
2M13 0976 35	40 x 1	m	3,7	115	60	0,40	1	15
2M13 0977 35	40 x 1 1/4	m	3,7	124	71	0,47	1	15
2M13 1078 35	50 x 1 1/2	m	4,6	132	71	0,60	1	12
2M13 1180 35	63 x 2	m	5,8	148	79	0,96	1	9
2M13 1283 35	75 x 2 1/2	m	6,8	163	83	1,23	1	9
2M13 1385 35	90 x 3	m	8,2	183	96	2,16	1	2
2M13 1487 35	110 x 4	m	10,0	202	117	3,48	1	2
2M13 1587 35	125 x 4	m	11,4	214	119	4,50	1	-

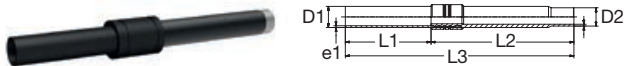

15103 PE100-Stahl Übergang lang (ohne Gewinde) **SDR11** schwarz  
PE100-Steel Transition long (without thread) **SDR11** black

Teil / Item	D1 x D2 [mm x Inch]	e1 [mm]	e2 [mm]	L1 [mm]	L2 [mm]	L3 [mm]	KG	VE1	VE2
2S13 0700 35	25 x 3/4	3,0	2,3	450	150	300	0,7	1	-
2S13 0800 35	32 x 1	3,0	2,6	450	150	300	1,1	1	-
2S13 0900 35	40 x 1 1/4	3,7	2,6	450	150	300	1,3	1	-
2S13 1000 35	50 x 1 1/2	4,6	2,9	450	150	300	2,0	1	-
2S13 1100 35	63 x 2	5,8	2,9	450	150	300	2,9	1	-
2S13 1200 35	75 x 2 1/2	6,8	3,2	500	200	300	3,7	1	-
2S13 1300 35	90 x 3	8,2	3,2	500	200	300	4,6	1	-
2S13 1400 35	110 x 4	10,0	3,6	500	200	300	6,4	1	-
2S13 1500 35	125 x 4	11,4	3,6	500	200	300	6,6	1	-
2S13 1600 35	140 x 5	12,7	5,0	550	250	300	10,5	1	-
2S13 1700 35	160 x 6	14,6	5,0	600	250	350	16,5	1	-
2S13 1800 35	180 x 6	16,4	5,0	600	250	350	22,5	1	-
2S13 1900 35	200 x 8	18,2	5,6	700	300	400	27,5	1	-
2S13 2000 35	225 x 8	20,5	5,6	700	300	400	30,0	1	-
2S13 2100 35	250 x 10								
2S13 2200 35	280 x 10								
2S13 2300 35	315 x 12								

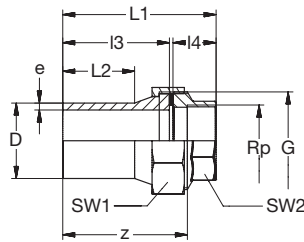

25.54.02.103 PE100-V2A Ü-Verschraubung lang IG-zyl Flachdichtring-EPDM SDR11 schwarz  
 PE100-Stainless steel Transition-Union long female-thread-cyl flat-gasket-EPDM SDR11 black

Teil / Item	D x Rp [mm x Inch]	Thread	e [mm]	G [Inch]	L1 [mm]	L2 [mm]	l3 [mm]	l4 [mm]	z [mm]	SW1 [mm]	SW2 [mm]	KG	VE1	VE2
2V53 0745 15	25 x 3/4	f	2,3	1 1/4	82	36	56	23	67	47	31	0,23	1	-
2V53 0846 15	32 x 1	f	3,0	1 1/2	94	42	65	26	77	53	38	0,28	1	-
2V53 0947 15	40 x 1 1/4	f	3,7	2	102	45	71	28	83	66	47	0,45	1	-
2V53 1048 15	50 x 1 1/2	f	4,6	2 1/4	113	52	81	29	94	72	53	0,61	1	-
2V53 1150 15	63 x 2	f	5,8	2 3/4	126	57	89	34	102	89	66	1,07	1	-
2V53 1253 15	75 x 2 1/2	f	6,9	3 1/2	179	71	130	46	152	109	82	1,67	1	-
2V53 1355 15	90 x 3	f	8,2	4	205	76	150	52	175	123	96	2,29	1	-
2V53 1357 15	90 x 4	f	8,2	5	219	76	164	60	180	150	124	3,10	1	-
2V53 1457 15	110 x 4	f	10,0	5	233	88	170	60	197	150	124	3,56	1	-

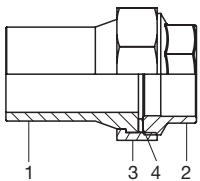

**Rohrverschraubung PE-V2A mit Flachdichtung und Anschluss für Metallgewinde**

1. PE Einlegeteil
2. V2A Einschraubteil
3. V2A Überwurfmutter
4. Flachdichtring-EPDM

**Union PE-Stainless steel with flat-gasket and connection for metal thread**

1. PE Insert-part
2. Stainless steel Screw-part
3. Stainless steel Union-nut
4. Flat-gasket-EPDM

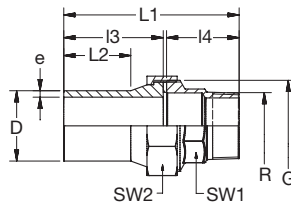

25.54.07.103 PE100-V2A Ü-Verschraubung lang AG-keg Flachdichtring-EPDM SDR11 schwarz  
 PE100-Stainless steel Transition-Union long male-thread-con flat-gasket-EPDM SDR11 black

Teil / Item	D x R [mm x Inch]	Thread	e [mm]	G [Inch]	L1 [mm]	L2 [mm]	l3 [mm]	l4 [mm]	SW1 [mm]	SW2 [mm]	KG	VE1	VE2
2V53 0775 15	25 x 3/4	m	2,3	1 1/4	109	36	56	50	47	31	0,26	1	-
2V53 0876 15	32 x 1	m	3,0	1 1/2	122	42	65	54	53	38	0,38	1	-
2V53 0977 15	40 x 1 1/4	m	3,7	2	128	45	71	54	66	47	0,59	1	-
2V53 1078 15	50 x 1 1/2	m	4,6	2 1/4	146	52	81	62	72	53	0,77	1	-
2V53 1180 15	63 x 2	m	5,8	2 3/4	161	57	89	69	89	66	1,19	1	-
2V53 1283 15	75 x 2 1/2	m	6,9	3 1/2	152	71	130	78	109	82	2,02	1	-
2V53 1385 15	90 x 3	m	8,2	4	240	76	150	87	123	96	2,61	1	-
2V53 1387 15	90 x 4	m	8,2	5	257	76	164	100	150	124	3,90	1	-
2V53 1487 15	110 x 4	m	10,0	5	273	88	170	100	150	124	4,44	1	-

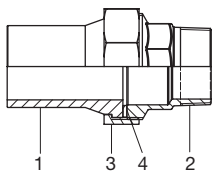

**Rohrverschraubung PE-V2A mit Flachdichtung und Anschluss für Metallgewinde**

1. PE Einlegeteil
2. V2A Einschraubteil
3. V2A Überwurfmutter
4. Flachdichtung-EPDM

**Union PE-Stainless steel with flat-gasket and connection for metal thread**

1. PE Insert-part
2. Stainless steel Screw-part
3. Stainless steel Union-nut
4. Flat-gasket-EPDM

## 2.01.05 Verschraubungen lang • Unions long

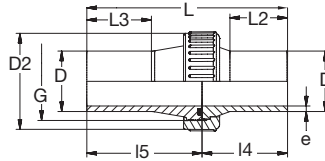

25.51.01.103 PE100 Verschraubung lang mit Runddichtring-EPDM **SDR11** schwarz  
PE100 Union long with O-Ring-gasket-EPDM **SDR11** black

Teil / Item	D [mm]	e [mm]	D2 [mm]	G [Inch]	L [mm]	L2 [mm]	L3 [mm]	l4 [mm]	l5 [mm]	L6 [mm]	H1 [mm]	H2 [mm]	KG	VE1	VE2
2353 0700 15	25	2,3	52	1 1/4	178	60	60	90	90	25	6	11	0,073	5	-
2353 0800 15	32	3,0	60	1 1/2	183	58	66	95	95	27	7	14	0,10	5	-
2353 0900 15	40	3,7	74	2	187	58	66	100	100	30	8	15	0,17	5	-
2353 1000 15	50	4,6	83	2 1/4	231	79	80	115	115	34	8	15	0,23	5	-
2353 1100 15	63	5,8	103	2 3/4	250	88	85	125	125	38	9	17	0,38	5	-
2353 1200 15	75	6,9	121	3 1/2	261	95	90	130	130	43	12	17	0,72	5	-
2353 1300 15	90	8,2	137	4	288	107	103	145	145	45	13	19	1,06	5	-
2353 1400 15	110	10,0	164	5	315	100	105	155	155	51	13	20	1,62	5	-

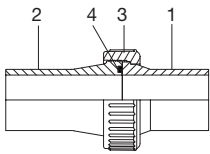

**Rohrverschraubung PE mit Runddichtring und beiseitigen Schweißenden**

1. PE Einlegeteil
2. PE Schraubteil
3. PVC Überwurfmutter
4. Runddichtring-EPDM/FPM

**Union PE with O-Ring-gasket and spigots on both sides.**

1. PE Insert-part
2. PE Screw-part
3. PVC Union-nut
4. O-Ring-gasket-EPDM/FPM

### Einzelteile • Spare parts

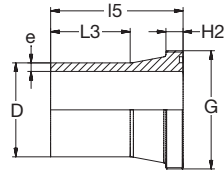

25.64.103 PE100 Schraubteil lang • Screw-part long

D [mm]	Teil / item	KG	VE1	VE2
25	2353 07S0 15	0,026	1	200
32	2353 08S0 15	0,039	1	100
40	2353 09S0 15	0,062	1	150
50	2353 10S0 05	0,10	1	80
63	2353 11S0 05	0,17	1	50
75	2353 12S0 05	0,26	1	25
90	2353 13S0 05	0,38	1	18
110	2353 14S0 05	0,61	1	12

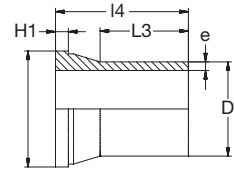

25.60.103 PE100 Einlegteil lang • Insert-part long

D [mm]	Teil / item	KG	VE1	VE2
25	2353 07E0 15	0,023	1	200
32	2353 08E0 15	0,036	1	100
40	2353 09E0 15	0,062	1	150
50	2353 10E0 05	0,10	1	80
63	2353 11E0 05	0,17	1	50
75	2353 12E0 05	0,26	1	25
90	2353 13E0 05	0,38	1	18
110	2353 14E0 05	0,62	1	12



648.41.00 Runddichtring / O-Ring-EPDM

D [mm]	Teil / item	KG	VE1	VE2
25	9201 07R1 35	0,001	10	-
32	9205 48R1 35	0,002	10	-
40	9205 50R1 35	0,003	10	-
50	9205 51R1 35	0,004	10	-
63	9205 54R1 35	0,005	10	-
75	9205 56R1 35	0,010	10	-
90	9205 57R1 35	0,010	10	-
110	9205 58R1 35	0,010	10	-



649.41.00 Runddichtring / O-Ring-FKM

D [mm]	Teil / item	KG	VE1	VE2
25	9201 07R3 35	0,001	10	-
32	9205 48R3 35	0,002	10	-
40	9205 50R3 35	0,003	10	-
50	9205 51R3 35	0,004	10	-
63	9205 54R3 35	0,005	10	-
75	9205 56R3 35	0,010	10	-
90	9205 57R3 35	0,010	10	-
110	9205 58R3 35	0,010	10	-

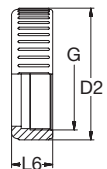

621.69.00 PVC Überwurfmutter • Union-nut

D [mm]	Teil / item	KG	VE1	VE2
25	1353 07U0 15	0,030	1	400
32	1353 08U0 15	0,040	1	300
40	1353 09U0 15	0,090	1	200
50	1353 10U0 15	0,15	1	160
63	1353 11U0 15	0,15	1	80
75	1353 12U0 15	0,21	1	-
90	1353 13U0 15	0,29	1	-
110	1353 14U0 15	0,40	1	-

## 2.01.06 Flanschverbindung lang • Flange connection long

### Vorschweißbund (V-Bund) lang in gerillter Ausführung für den Einsatz von Flachdichtungen.

Weitere Informationen zu Flanschen und Dichtungen finden Sie unter 6. Zubehör.

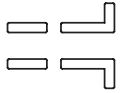

### Flange adaptor spigot long grooved for the use of flat-gaskets.

More information about flanges and gaskets see 6. Accessories.

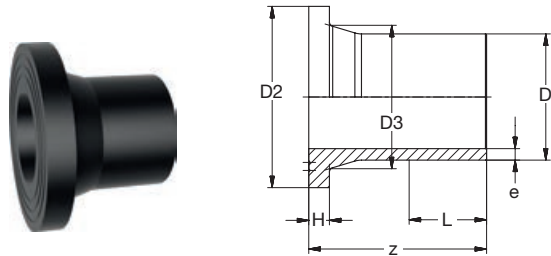

25.80.01.103 PE100 V-Bund lang gerillt **SDR11** schwarz  
PE100 Flange adaptor spigot long grooved **SDR11** black

Teil / Item	D [mm]	e [mm]	D2 [mm]	D3 [mm]	H [mm]	L [mm]	z [mm]	KG	VE1	VE2
2333 07F0 15	25	2,3	58	33	9,0	51	90	0,040	10	180
2333 08F0 15	32	3,0	68	40	10,5	57	95	0,060	10	80
2333 09F0 15	40	3,7	78	50	11,6	55	100	0,080	10	60
2333 10F0 15	50	4,6	88	61	12,0	63	110	0,13	10	60
2333 11F0 15	63	5,8	102	75	14,5	66	122	0,21	5	40
2333 12F0 15	75	6,9	122	89	16,5	78	130	0,32	2	18
2333 13F0 15	90	8,2	138	105	17,5	84	142	0,48	2	12
2333 14F0 15	110	10,0	158	125	18,5	105	155	0,71	2	12
2333 15F0 15	125	11,4	158	132	26,0	106	172	0,93	2	8
2333 16F0 15	140	12,7	188	155	25,0	109	172	1,26	1	4
2333 17F0 15	160	14,6	212	175	25,0	110	182	1,66	1	6
2333 18F0 15	180	16,4	212	180	31,0	115	195	1,94	1	4
2333 19F0 15	200	18,2	268	232	32,0	135	205	3,14	1	2
2333 20F0 15	225	20,5	268	235	32,5	145	213	3,40	1	-
2333 21F0 15	250	22,7	320	285	35,0	156	235	5,25	1	-
2333 22F0 15	280	25,4	320	291	35,0	160	255	5,82	1	-
2333 23F0 15	315	28,6	370	335	35,0	172	257	8,05	1	-
2333 24F0 15	355	32,2	430	373	40,0	182	280	11,3	1	-
2333 25F0 15	400	36,3	482	427	45,0	192	315	16,1	1	-
2333 26F0 15	450	40,9	585	514	60,0	220	326-340	26,0	1	-
2333 27F0 15	500	45,4	585	530	60,0	234	330-360	29,0	1	-
2333 28F0 35	560	50,8	685	615	60,0	260	370-380	47,1	1	-
2333 29F0 15	630	57,2	685	642	65,0	270	360-375	42,3	1	-

25.80.01.063 PE100 V-Bund lang gerillt **SDR17** schwarz  
PE100 Flange adaptor spigot long grooved **SDR17** black

Teil / Item	D [mm]	e [mm]	D2 [mm]	D3 [mm]	H [mm]	L [mm]	z [mm]	KG	VE1	VE2
2334 11F0 15	63	3,8	102	75	14	66	122	0,18	5	40
2334 12F0 15	75	4,5	122	89	18	78	130	0,27	2	18
2334 13F0 15	90	5,4	138	105	18	84	142	0,38	2	12
2334 14F0 15	110	6,6	158	125	18	105	155	0,56	2	12
2334 15F0 15	125	7,4	158	132	18	106	172	0,63	2	8
2334 16F0 15	140	8,3	188	155	18	109	172	0,90	1	4
2334 17F0 15	160	9,5	212	175	18	110	182	1,12	1	6
2334 18F0 15	180	10,7	212	180	20	115	195	1,36	1	4
2334 19F0 15	200	11,9	268	232	24	135	205	2,28	1	2
2334 20F0 15	225	13,4	268	235	24	145	213	2,33	1	1
2334 21F0 15	250	14,8	320	285	25	156	235	3,60	1	-
2334 22F0 15	280	16,6	320	291	25	160	255	4,16	1	-
2334 23F0 15	315	18,7	370	335	25	172	257	5,56	1	-
2334 24F0 15	355	21,1	430	373	30	182	280	7,83	1	-
2334 25F0 15	400	23,7	482	427	33	192	315	11,1	1	-
2334 26F0 15	450	26,7	585	514	46	220	326-340	18,3	1	-
2334 27F0 15	500	29,7	585	530	46	234	330-360	20,0	1	-
2334 28F0 35	560	33,2	685	615	50	260	370-380	27,2	1	-
2334 29F0 15	630	37,4	685	642	50	270	360-375	29,3	1	-

**Zubehör Flanschverbindung PE (V-Bund) • Accessories Flange Connection PE (V-Bund)**



Losflansch  
Flange loose

D [mm]	DN [mm]	PP-St				St beschichtet St coated	PP-GGG	PP-St
		DIN/EN				PN10	ANSI	
		PN10/16	PN10	PN16	PN10		150 lbs	
25	20	9141 07E1 15						9141 07A2 38
32	25	9141 08E1 15						9141 08A2 38
40	32	9141 09E1 15						9141 09A2 38
50	40	9141 10E1 15						9141 10A2 38
63	50	9141 11E1 15					9151 11A2 25	
75	65	9141 12E1 15						9141 12A2 38
90	80	9143 13E1 15					9153 13A2 25	
110	100	9143 14E1 15					9153 14A2 25	
125	100	9143 15E1 15						9143 14A2 38
140	125	9143 16E1 15						
160	150	9143 17E1 15					9153 17A2 25	
180	150	9143 18E1 15					9153 18A2 35	
200	200		9143 19E2 15	9143 19E3 35		9153 19A2 25		
225	200		9143 20E2 15	9143 20E3 35		9153 19A2 25		
250	250		9143 21E2 15	9143 21E3 35		9153 21A2 25		
280	250		9143 22E2 15	9143 22E3 35				
315	300		9143 23E2 15	9143 23E3 35		9153 23A2 25		
355	350		9143 24E2 15	9143 24E3 35			9143 24A2 38	
400	400		9143 25E2 15	9143 25E3 35			9143 25A2 38	
450	500		9143 26E2 35					
500	500		9143 27E2 35				9143 27A2 38	
560	600		9143 28E2 35					
630	600		9143 29E2 35					
710	700				9113 30E2 05			
800	800				9113 31E2 05			
900	900				9113 32E2 05			
1000	1000				9113 33E2 05			



Blindflansch  
Flange blind



Flachdichtung mit Stahleinlage  
Flat gasket with steel-inlay

D [mm]	DN [mm]	PP-St			EPDM		NBR	
		DIN/EN		ANSI	Wasser / Water		Gas / Gas	
		PN10/16	PN10	150 lbs	SDR11	SDR17	SDR11	SDR17
25	20	9144 07E1 35		9144 07A2 38	9203 07F1 35		9203 07F2 35	
32	25	9144 08E1 35		9144 08A2 38	9203 08F1 35		9203 08F2 35	
40	32	9144 09E1 35		9144 09A2 38	9203 09F1 35		9203 09F2 35	
50	40	9144 10E1 35		9144 10A2 38	9203 10F1 35		9203 10F2 35	
63	50	9144 11E1 35		9144 11A2 38	9203 11F1 35		9203 11F2 35	
75	65	9144 12E1 35		9144 12A2 38	9203 12F1 35	9204 12F1 35	9203 12F2 35	9204 12F2 35
90	80	9144 13E1 35		9144 13 A2 38	9203 13F1 35	9204 13F1 35	9203 13F2 35	9204 13F2 35
110	100	9144 14E1 35		9144 14 A2 38	9203 14F1 35	9204 14F1 35	9203 14F2 35	9204 14F2 35
125	100	9144 14E1 35			9203 15F1 35	9204 15F1 35	9203 15F2 35	9204 15F2 35
140	125	9144 16E1 35			9203 16F1 35	9204 16F1 35	9203 16F2 35	9204 16F2 35
160	150	9144 17E1 35		9144 17A2 38	9203 17F1 35	9204 17F1 35	9203 17F2 35	9204 17F2 35
180	150	9144 17E1 35			9203 18F1 35	9204 18F1 35	9203 18F2 35	9204 18F2 35
200	200		9144 19E2 35	9144 19A2 38	9203 19F1 35	9204 19F1 35	9203 19F2 35	9204 19F2 35
225	200		9144 19E2 35		9203 20F1 35	9204 20F1 35	9203 20F2 35	9204 20F2 35
250	250		9144 21E2 35	9144 21A2 38	9203 21F1 35	9204 21F1 35	9203 21F2 35	9204 21F2 35
280	250		9144 21E2 35		9203 22F1 35	9204 22F1 35	9203 22F2 35	9204 22F2 35
315	300		9144 23E2 35	9144 23A2 38	9203 23F1 35	9204 23F1 35	9203 23F2 35	9204 23F2 35
355	350		9144 24E2 35		9203 24F1 35	9204 24F1 35	9203 24F2 35	9204 24F2 35
400	400		9144 25E2 35		9203 25F1 35	9204 25F1 35	9203 25F2 35	9204 25F2 35
450	500				9203 26F1 35	9204 26F1 35	9203 26F2 35	9204 26F2 35
500	500				9203 27F1 35	9204 27F1 35	9203 27F2 35	9204 27F2 35
560	600				9203 28F1 35	9204 28F1 35	9203 28F2 35	9204 28F2 35
630	600				9203 29F1 35	9204 29F1 35	9203 29F2 35	9204 29F2 35

## 2.01.06 Flanschverbindung lang • Flange connection long

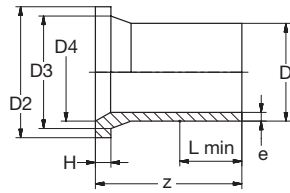

PE100 V-Bund für Klappen lang gerillt **SDR11** schwarz

PE100 Flange adaptor spigot for valves long grooved **SDR11** black

Teil / Item	D [mm]	e [mm]	D2 [mm]	D3 [mm]	D4 [mm]	H [mm]	L min [mm]	z [mm]	KG	VE1	VE2
2333 12FK 15	75	6,9	122	89	62	16	78	130	0,31	2	24
2333 13FK 15	90	8,2	138	105	82	17	84	145	0,35	2	24
2333 14FK 15	110	10,0	158	125	100	18,0	96	155	0,54	2	12
2333 16FK 15	140	12,7	188	155	127	25	109	175	0,97	1	8
2333 17FK 15	160	14,6	212	175	153	25	110	185	1,25	1	6
2333 18FK 15	180	16,4	212	180	154	25	115	195	1,35	1	4
2333 19FK 15	200	18,2	268	232	208	32	127	205	2,48	1	3
2333 20FK 15	225	20,5	268	235	204	32	137	215	3,42	1	-
2333 21FK 15	250	22,7	320	285	254	35	146	235	5,26	1	-
2333 22FK 15	280	25,4	320	291	260	35	156	253	5,82	1	-
2333 23FK 15	315	28,6	370	335	309	35	165	257	8,05	1	-
2333 24FK 15	355	32,2	430	373	340	40	172	257	11,3	1	-

PE100 V-Bund für Klappen lang gerillt **SDR17** schwarz

PE100 Flange adaptor spigot for valves long grooved **SDR17** black

Teil / Item	D [mm]	e [mm]	D2 [mm]	D3 [mm]	D4 [mm]	H [mm]	L min [mm]	z [mm]	KG	VE1	VE2
2334 11FK 15	63	3,8	102	75	59	14	18	78	0,11	2	12
2334 12FK 15	75	4,5	122	89	71	16	28	78	0,21	2	36
2334 13FK 15	90	5,4	138	105	85	17	29	88	0,30	2	24
2334 14FK 15	110	6,6	158	125	103,6	18	41	100	0,46	2	12
2334 15FK 15	125	7,4	158	132	114	18	48	110	0,45	2	10
2334 16FK 15	140	8,3	188	155	127	18	54	120	0,69	1	8
2334 17FK 15	160	9,5	212	175	153	18	55	130	0,91	1	6
2334 19FK 15	200	11,9	268	232	204	24	67	145	1,80	1	3
2334 20FK 15	225	13,4	268	235	204	24	72	130	1,77	1	3
2334 21FK 15	250	14,8	320	285	254	25	77	160	2,72	1	2
2334 22FK 15	280	16,6	320	291	260	25	81	170	4,16	1	-
2334 23FK 15	315	18,7	370	335	309	25	95	190	4,24	1	-
2334 25FK 15	355	21,1	430	373	340	30	97	195	7,83	1	-

**PE100 Sonder-Flanschverbindung lang**

**PE100 Special flange connection long**

**Ausführung**

Langes Schweißende; für Heizelement-Stumpf-Schweißen und E-Muffen-Schweißen geeignet. Gebohrt nach DIN EN 1092-1. Standardmäßig mit Runddichtring-EPDM. SDR11/17 und PN10/16.

Mit kunststoffbeschichtetem Sphäroguss- oder Stahlflansch. Ausführung abhängig von der SDR-Klasse und DN/D-Kombination.

**Optional**

Flansche aus Edelstahl; Flansche aus verzinktem Stahl; flachdichtend ohne Nut und ohne O-Ring; PN25 gebohrt; mit Langloch.

Für Gasleitungen mit glatter Dichtfläche oder NBR-Dichtung lieferbar.

**Anwendung**

Direkter Anschluss an Armaturen ohne Reduzierung der Nennweite (DN).

**Besonderheiten**

- Besonders stabil
- Strömungsgünstig
- Reduzierter Totraum
- Integrierte O-Ring-Dichtung
- Klappe der Armatur ist frei beweglich

**Type**

Long welding end; for the use of butt-welding electrofusion socket-welding. Drilled according to DIN EN 1092-1. By default inclusive O-Ring-gasket-EPDM. SDR11/17 and PN10/16.

With ductile cast iron or steel backing rings, plastic coated. Type depending on the SDR-Class and on the combination of DN/D.

**Optional**

Stainless steel backing rings; hot dipped galvanized backing rings; flat sealing surface without flute or O-ring; PN25 drilled; with slotted holes.

Available for gas pipes with flat surface or NBR-Gaskets.

**Application**

For direct connection to valves according to nominal diameter (DN).

**Special features**

- Extra stable
- Streamlined
- Reduced dead space
- Integrated O-ring seal
- Disc of the valve is free to move

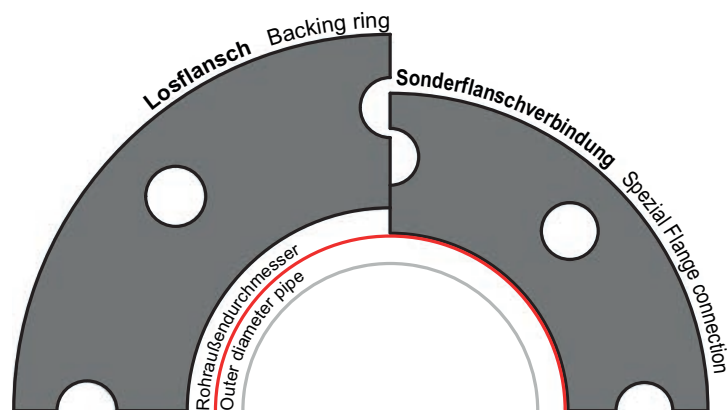

## 2.01.06 Flanschverbindung lang • Flange connection long

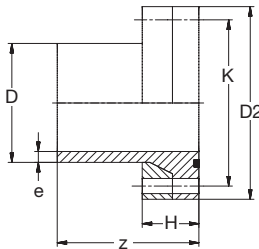

25.75.01.103 PE100 Sonder-Flanschverbindung lang **SDR11** schwarz  
PE100 Special flange connection long **SDR11** black

Teil / Item	D [mm]	PN gebohrt drilled	DN [mm]	e [mm]	D2 [mm]	Z [mm]	H [mm]	nL [mm]	DL [mm]	DK [mm]			VE1	VE2
9115 13E1 39	90	10/16	65	8,2	185	150	40	4	18	145	M16	3,50	1	-
9115 14E1 39	110	10/16	80	10,0	200	155	40	8	18	160	M16	4,50	1	-
9115 16E1 39	140	10/16	100	12,7	220	180	45	8	18	180	M16	5,00	1	-
9115 17E1 39	160	10/16	125	14,6	250	190	45	8	18	210	M16	6,50	1	-
9115 18E1 39	180	10/16	125	16,4	250	195	45	8	18	210	M16	6,50	1	-
9115 19E1 39	200	10/16	150	18,2	285	205	50	8	22	240	M20	8,00	1	-
9115 21E3 39	250	16	200	22,8	340	245	65	12	22	295	M20	13,0	1	-
9115 23E3 39	315	16	250	28,7	405	275	65	12	26	355	M24	20,0	1	-
9115 24E3 39	355	16	300	32,3	460	275	65	12	26	410	M24	26,0	1	-
9115 25E3 39	400	16	350	36,4	520	330	95	16	26	470	M24	39,0	1	-
9115 26E3 39	450	16	400	41,1	580	340	105	16	30	525	M27	52,5	1	-
9115 27E3 39	500	16	500	45,4	565	600	92	16	30	525	M27	63,5	1	-
9115 28E3 39	560	16	500	51,0	715	395	105	20	33	650	M30	83,0	1	-
9115 29E3 39	630	16	500	57,2	715	255	105	20	33	650	M30	95,5	1	-
9115 21E2 39	250	10	200	22,8	340	240	60	8	22	295	M20	12,0	1	-
9115 23E2 39	315	10	250	28,7	395	270	60	12	22	350	M20	17,0	1	-
9115 24E2 39	355	10	300	32,3	445	270	60	12	22	400	M20	22,0	1	-
9115 25E2 39	400	10	350	36,4	505	325	90	16	22	460	M20	30,0	1	-
9115 26E2 39	450	10	400	41,1	565	335	100	16	26	515	M24	39,0	1	-
9115 27E2 39	500	10	400	45,4	565	590	81	16	26	515	M24	50,0	1	-
9115 28E2 39	560	10	500	51,0	670	370	100	20	26	620	M24	58,0	1	-
9115 29E2 39	630	10	500	57,2	670	255	100	20	26	620	M24	117,0	1	-

25.75.01.063 PE100 Sonder-Flanschverbindung lang **SDR17** schwarz  
PE100 Special flange connection long **SDR17** black

Teil / Item	D [mm]	PN gebohrt drilled	DN [mm]	e [mm]	D2 [mm]	Z [mm]	H [mm]	nL [mm]	DL [mm]	DK [mm]			VE1	VE2
9116 13E1 39	90	10/16	65	8,2	185	150	40	4	18	145	M16	3,50	1	-
9116 14E1 39	110	10/16	80	10,0	200	155	40	8	18	160	M16	4,50	1	-
9116 16E1 39	140	10/16	100	12,7	220	180	45	8	18	180	M16	5,00	1	-
9116 17E1 39	160	10/16	125	14,6	250	190	45	8	18	210	M16	6,50	1	-
9116 18E1 39	180	10/16	125	16,4	250	195	45	8	18	210	M16	6,50	1	-
9116 19E1 39	200	10/16	150	18,2	285	205	50	8	22	240	M20	8,00	1	-
9116 21E3 39	250	16	200	22,8	268	350	64	12	22	295	M20	13,0	1	-
9116 23E3 39	315	16	250	28,7	315	380	72	12	26	355	M24	20,0	1	-
9116 24E3 39	355	16	300	32,3	275	360	74	12	26	410	M24	26,0	1	-
9116 25E3 39	400	16	350	36,4	380	430	89	16	26	470	M24	39,0	1	-
9116 26E3 39	450	16	400	41,1	560	430	92	16	30	525	M27	52,5	1	-
9116 27E3 39	500	16	500	45,4	565	600	92	16	30	525	M27	63,5	1	-
9116 28E3 39	560	16	500	51,0	400	440	98	20	33	650	M30	83,0	1	-
9116 29E3 39	630	16	500	57,2	610	620	98	20	33	650	M30	95,5	1	-
9116 21E2 39	250	10	200	22,8	340	240	60	8	22	295	M20	12,0	1	-
9116 23E2 39	315	10	250	28,7	395	270	60	12	22	350	M20	17,0	1	-
9116 24E2 39	355	10	300	32,3	445	270	60	12	22	400	M20	22,0	1	-
9116 25E2 39	400	10	350	36,4	505	325	90	16	22	460	M20	30,0	1	-
9116 26E2 39	450	10	400	41,1	565	335	100	16	26	515	M24	39,0	1	-
9116 27E2 39	500	10	400	45,4	565	570	81	16	26	515	M24	50,0	1	-
9116 28E2 39	560	10	500	51,0	670	370	100	20	26	620	M24	58,0	1	-
9116 29E2 39	630	10	500	57,2	670	255	100	20	26	620	M24	117,0	1	-

## 2.01.07 Kugelhähne lang • Ball valves long

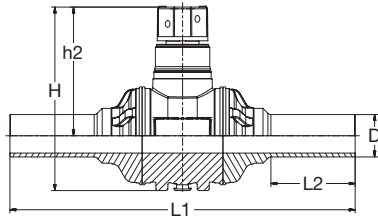

35203

35503

35303

PE100 Kugelhahn G/W/S PN10 lang Anschlüsse **SDR11** schwarz  
 PE100 Ball valve G/W/S PN10 long connectors **SDR11** black

Teil / Item			D [mm]	L1 [mm]	L2 [mm]	H1 [mm]	h2 [mm]	G KG	W KG	S KG	VE1	VE2
G	W	S										
2913 08G0 35	2913 08W0 35	2913 08S0 35	<b>32</b>	322	58	190	139	1,0			1	-
2913 09G0 35	2913 09W0 35	2913 09S0 35	<b>40</b>	410	100	203	145	1,2			1	-
2913 10G0 35	2913 10W0 35	2913 10S0 35	<b>50</b>	415	100	217	152	1,6			1	-
2913 11G0 35	2913 11W0 35	2913 11S0 35	<b>63</b>	435	100	252	176	2,7	3,7	2,5	1	-
2913 12G0 35	2913 12W0 35	2913 12S0 35	<b>75</b>	515	105	267	182	3,5	3,9	3,2	1	-
2913 13G0 35	2913 13W0 35	2913 13S0 35	<b>90</b>	550	110	299	200	6,2	6,2	5,0	1	-
2913 14G0 35	2913 14W0 35	2913 14S0 35	<b>110</b>	595	115	320	210	8,5	7,8	6,6	1	-
2913 15G0 35	2913 15W0 35	2913 15S0 35	<b>125</b>	610	125	320	210	9,1	8,4	7,2	1	-
2913 17G0 35	2913 17W0 35	2913 17S0 35	<b>160</b>	690	120	403	254	19,7	14,9	13,4	1	-
2913 18G0 35	2913 18W0 35	2913 18S0 35	<b>180</b>	690	120	403	254	20,0	16,0	14,5	1	-

G = Gas/Gas

W = Wasser/Water

S = Abwasser/sewage water



621.342.200

621.342.205

PE100-PVC-U Kugelhahn lang Anschlüsse **SDR11** schwarz  
 PE100-PVC-U Ball valve long connectors **SDR11** black

Teil / Item		D [mm]	VE1
EPDM	FKM (FPM)		
2913 07R1 25	2913 07R3 25	<b>25</b>	1
2913 08R1 25	2913 08R3 25	<b>32</b>	1
2913 09R1 25	2913 09R3 25	<b>40</b>	1
2913 10R1 25	2913 10R3 25	<b>50</b>	1
2913 11R1 25	2913 11R3 25	<b>63</b>	1

### PE100 Formteile mit kurzen Schweißenden SDR11/17 schwarz

gespritzt, für die Heizelement-Stumpf-Schweißung

### PE100 Fittings with short spigots SDR11/17 black

injection moulded, for butt-welding

#### Werkstoff

PE100, schwarz. Das Material entspricht den Anforderungen der aktuellen KTW-Leitlinie des Umweltbundesamtes (UBA).

#### Geometrische Eigenschaften

Außendurchmesser und Wanddicke entsprechend EN 1555 und EN 12201.

Toleranzen bei den Z-Maßangaben sind abhängig von der Dimension. Bis d/D 160 = +/- 3 mm. Ab d/D 180 = +/- 10 mm.

#### Ausführung

Geeignet für Heizelement-Stumpf-Schweißung nach DVS Richtlinie 2207.

Schweiß-Geräte und Schweiß-Werkzeuge sollten der DVS Richtlinie 2208 entsprechen.

#### Material

PE100, black. The material complies with the requirements of the KTW guideline of the German Federal Environmental Agency (UBA).

#### Geometric Properties

Outside diameter and wall thickness according to EN 1555 and EN 12201.

Tolerances of z-sizes depend on the dimension. Up to d/D 160 = +/- 3 mm and from d/D 180 = +/- 10 mm.

#### Type

Suitable for butt-welding according to DVS technical code 2207. Welding equipment according to DVS technical code 2208.

## 2.02.01 Bögen + Winkel kurz • Bends + Elbows short

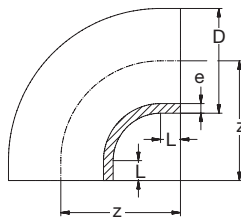

25.00.00.101 PE100 Bogen 90° kurz **SDR11** schwarz  
PE100 Bend 90° short **SDR11** black

Teil / Item	D [mm]	e [mm]	L [mm]	z [mm]	KG	VE1	VE2
2425 0690 35	20	1,8	3	27	0,005	10	-
2425 0790 35	25	2,3	5	32	0,010	10	140
2425 0890 35	32	3,0	6	37	0,020	10	80
2425 0990 35	40	3,7	8	44	0,030	10	40
2425 1090 35	50	4,6	10	51	0,070	5	40
2425 1190 35	63	5,8	12	66	0,14	5	50
2425 1290 35	75	6,9	14	87	0,25	2	26
2425 1390 35	90	8,2	15	100	0,35	2	16
2425 1490 35	110	10,0	15	118	0,69	2	8
2425 1590 35	125	11,4	15	138	1,05	1	6
2425 1690 35	140	12,7	20	155	1,45	1	4
2425 1790 35	160	14,6	25	178	1,98	1	3
2425 1890 35	180	16,4	25	195	2,83	1	2
2425 1990 35	200	18,2	20	210	3,91	1	-
2425 2090 35	225	20,5	25	236	5,40	1	-
2425 2190 35	250	22,7	30	279	7,26	1	-
2425 2290 35	280	25,4	40	316	10,5	1	-
2425 2390 35	315	28,6	40	352	14,6	1	-
2425 2490 35	355	32,2	40	340	17,2	1	-

25.00.00.061 PE100 Bogen 90° kurz **SDR17** schwarz  
PE100 Bend 90° short **SDR17** black

Teil / Item	D [mm]	e [mm]	L [mm]	z [mm]	KG	VE1	VE2
2426 1090 35	50	3,0	10	51	0,049	5	40
2426 1190 35	63	3,8	12	66	0,080	5	50
2426 1290 35	75	4,5	14	87	0,18	2	26
2426 1390 35	90	5,4	15	100	0,29	2	16
2426 1490 35	110	6,6	15	118	0,49	2	8
2426 1590 35	125	7,4	15	138	0,79	1	6
2426 1690 35	140	8,3	20	155	1,07	1	4
2426 1790 35	160	9,5	25	178	1,54	1	3
2426 1890 35	180	10,7	25	195	2,29	1	2
2426 1990 35	200	11,9	20	210	3,10	1	-
2426 2090 35	225	13,4	25	236	4,19	1	-
2426 2190 35	250	14,8	30	279	4,73	1	-
2426 2290 35	280	16,6	40	316	6,79	1	-
2426 2390 35	315	18,7	40	352	9,49	1	-

## 2.02.01 Bögen + Winkel kurz • Bends + Elbows short

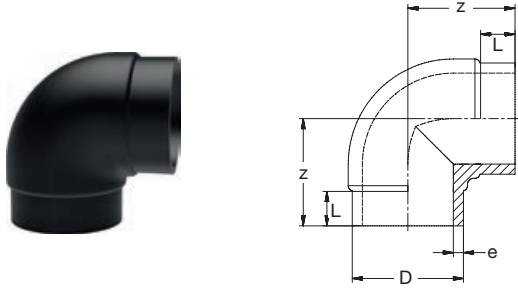

25.10.01.101 PE100 Winkel 90° kurz **SDR11** schwarz  
PE100 Elbow 90° short **SDR11** black

Teil / Item	D [mm]	e [mm]	L [mm]	z [mm]	KG	VE1	VE2
2415 0790 15	25	2,3	12	36	0,014	5	180
2415 0890 15	32	3,0	14	39	0,026	5	130
2415 0990 15	40	3,7	16	46	0,046	5	75
2415 1090 15	50	4,6	18	47	0,090	5	50
2415 1190 15	63	5,8	22	63	0,18	5	45
2415 1290 15	75	6,9	25	70	0,24	2	30
2415 1390 15	90	8,2	28	91	0,40	2	16
2415 1490 15	110	10,0	34	101	0,78	2	10
2415 1590 15	125	11,4	42	120	1,25	2	8
2415 1690 15	140	12,7	45	125	1,60	1	4
2415 1790 15	160	14,6	50	146	2,36	1	2
2415 1890 15	180	16,4	55	171	3,29	1	2
2415 1990 15	200	18,2	60	188	4,38	1	-
2415 2090 15	225	20,5	65	205	6,17	1	-
2415 2190 15	250	22,7	70	222	7,80	1	-
2415 2290 15	280	25,4	80	259	10,7	1	-
2415 2390 15	315	28,6	90	295	14,9	1	-

25.10.01.061 PE100 Winkel 90° kurz **SDR17** schwarz  
PE100 Elbow 90° short **SDR17** black

Teil / Item	D [mm]	e [mm]	L [mm]	z [mm]	KG	VE1	VE2
2416 1290 15	75	4,5	25	70	0,22	2	30
2416 1390 15	90	5,4	28	91	0,32	2	16
2416 1490 15	110	6,6	34	101	0,60	2	8
2416 1590 15	125	7,4	42	120	0,89	1	8
2416 1690 15	140	8,3	45	125	1,25	1	4
2416 1790 15	160	9,5	50	146	1,77	1	3
2416 1890 15	180	10,7	55	171	2,49	1	2
2416 1990 15	200	11,9	60	188	3,24	1	-
2416 2090 15	225	13,4	65	205	4,39	1	-
2416 2190 15	250	14,8	70	222	5,96	1	-
2416 2290 15	280	16,6	80	259	8,24	1	-
2416 2390 15	315	18,7	90	295	11,3	1	-

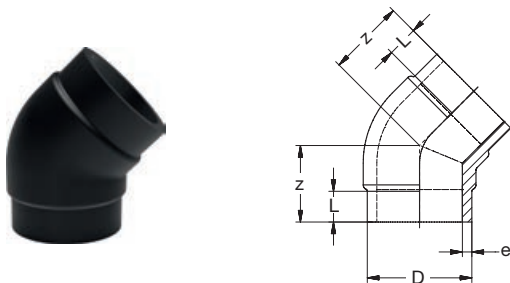

25.15.01.101 PE100 Winkel 45° kurz **SDR11** schwarz  
PE100 Elbow 45° short **SDR11** black

Teil / Item	D [mm]	e [mm]	L [mm]	z [mm]	KG	VE1	VE2
2415 0745 15	25	2,3	12	21	0,01	10	300
2415 0845 15	32	3,0	14	30	0,02	10	300
2415 0945 15	40	3,7	16	40	0,05	5	150
2415 1045 15	50	4,6	18	42	0,08	1	100
2415 1145 15	63	5,8	22	49	0,14	1	60
2415 1245 15	75	6,9	25	68	0,17	1	45
2415 1345 15	90	8,2	28	66	0,35	2	20
2415 1445 15	110	10,0	34	79	0,54	2	12
2415 1645 15	140	12,7	45	97	1,30	1	5
2415 1745 15	160	14,6	50	108	1,85	1	2
2415 1845 15	180	16,4	55	112	2,56	1	-
2415 1945 15	200	18,2	60	125	3,33	1	-
2415 2045 15	225	20,5	65	131	5,03	1	-
2415 2145 15	250	22,7	70	166	6,44	1	-
2415 2245 15	280	25,4	80	183	8,84	1	-
2415 2345 15	315	28,6	90	200	11,7	1	-

25.15.01.061 PE100 Winkel 45° kurz **SDR17** schwarz  
PE100 Elbow 45° short **SDR17** black

Teil / Item	D [mm]	e [mm]	L [mm]	z [mm]	KG	VE1	VE2
2416 1245 15	75	4,5	25	68	0,13	1	-
2416 1345 15	90	5,4	28	66	0,27	2	20
2416 1445 15	110	6,6	34	79	0,43	2	12
2416 1645 15	140	8,3	45	97	0,87	1	5
2416 1745 15	160	9,5	50	108	1,31	1	2
2416 1845 15	180	10,7	55	112	1,87	1	-
2416 1945 15	200	11,9	60	125	2,44	1	-
2416 2045 15	225	13,4	65	131	3,37	1	-
2416 2145 15	250	14,8	70	166	4,62	1	-
2416 2245 15	280	16,6	80	183	6,59	1	-
2416 2345 15	315	18,7	90	200	9,06	1	-

## 2.02.02 T-Stücke kurz • Tee's short

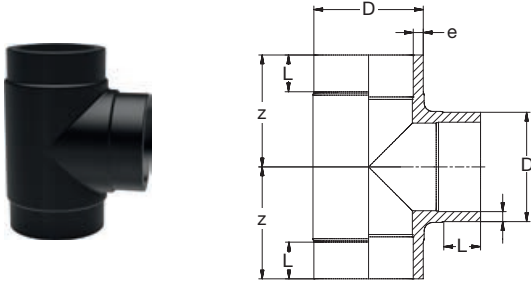

25.20.01.101 PE100 T-Stück 90° kurz **SDR11** schwarz  
PE100 Tee 90° short **SDR11** black

Teil / Item	D [mm]	e [mm]	L [mm]	z [mm]	KG	VE1	VE2
2515 0790 15	25	2,3	12	33	0,025	5	150
2515 0890 15	32	3,0	14	37	0,040	5	85
2515 0990 15	40	3,7	16	42	0,070	5	125
2515 1090 15	50	4,6	18	51	0,14	5	70
2515 1190 15	63	5,8	22	67	0,22	5	30
2515 1290 15	75	6,9	25	75	0,36	2	20
2515 1390 15	90	8,2	28	98	0,67	2	10
2515 1490 15	110	10,0	34	109	1,04	2	6
2515 1590 15	125	11,4	42	128	1,37	1	6
2515 1690 15	140	12,7	45	137	1,98	1	3
2515 1790 15	160	14,6	50	152	3,07	1	2
2515 1890 15	180	16,4	55	172	4,29	1	2
2515 1990 15	200	18,2	60	190	5,65	1	-
2515 2090 15	225	20,5	65	215	8,58	1	-
2515 2190 15	250	22,7	70	222	9,40	1	-
2515 2290 15	280	25,4	80	259	17,7	1	-
2515 2390 15	315	28,6	90	295	22,9	1	-
2515 2490 35	355	32,2		340	26,9	1	-

25.20.01.061 PE100 T-Stück 90° kurz **SDR17** schwarz  
PE100 Tee 90° short **SDR17** black

Teil / Item	D [mm]	e [mm]	L [mm]	z [mm]	KG	VE1	VE2
2516 1090 35	50	3,0	18	51	0,090	5	70
2516 1190 35	63	3,8	22	67	0,17	5	30
2516 1290 15	75	4,5	25	75	0,26	2	20
2516 1390 35	90	5,4	28	98	0,50	2	10
2516 1490 15	110	6,6	34	109	0,88	2	6
2516 1590 15	125	7,4	42	128	1,02	2	6
2516 1690 15	140	8,3	45	137	1,63	1	3
2516 1790 15	160	9,5	50	152	2,58	1	2
2516 1890 15	180	10,7	55	172	3,06	1	2
2516 1990 15	200	11,9	60	190	4,10	1	-
2516 2090 15	225	13,4	65	215	6,19	1	-
2516 2190 15	250	14,8	70	222	6,72	1	-
2516 2290 35	280	16,6	80	259	12,0	1	-
2516 2390 35	315	18,7	90	295	17,5	1	-

PE100

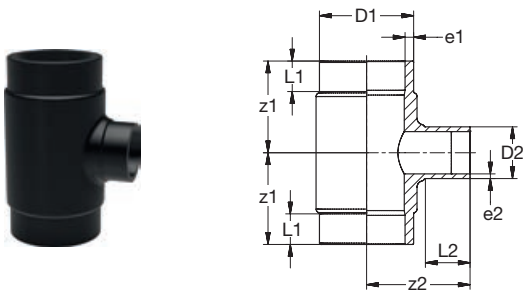

25.20.01.101 PE100 T-Stück 90° red kurz **SDR11** schwarz  
PE100 Tee 90° red short **SDR11** black

Teil / Item	D1-D2 [mm]	e1 [mm]	e2 [mm]	L1 [mm]	L2 [mm]	z1 [mm]	z2 [mm]	KG	VE1	VE2
2525 1108 15	63-32	5,8	3,0	22	15	67	69	0,19	2	6
2525 1411 15	110-63	10,0	5,8	48	32	120	105	0,90	2	6
2525 1413 15	110-90	10,0	8,2	48	38	120	115	0,97	2	6
2525 1714 15	160-110	14,6	10,0	56	38	160	145	2,81	1	-
2525 1917 35	200-160	18,2	14,6	98	53	194	178	5,20	1	-
2525 2014 15	225-110	20,5	10,0	89	88	220	264	7,07	1	-
2525 2015 15	225-125	20,5	11,4	79	32	185	205	6,39	1	-
2525 2017 15	225-160	20,5	14,6	89	60	235	200	7,21	1	-

25.20.01.061 PE100 T-Stück 90° red kurz **SDR17** schwarz  
PE100 Tee 90° red short **SDR17** black

Teil / Item	D1-D2 [mm]	e1 [mm]	e2 [mm]	L1 [mm]	L2 [mm]	z1 [mm]	z2 [mm]	KG	VE1	VE2
2526 1411 15	110-63	6,6	5,8*	48	32	120	105	0,73	2	6
2526 1413 15	110-90	6,6	5,4	48	38	120	115	0,75	2	6
2526 1714 15	160-110	9,5	6,6	56	38	160	145	2,13	1	-
2526 1917 35	200-160	11,9	9,5	134	114	275	265	3,70	1	-
2526 2014 15	225-110	13,4	6,6	89	88	220	264	5,52	1	-
2526 2015 15	225-125	13,4	7,4	79	32	185	205	5,54	1	-
2526 2017 15	225-160	13,4	9,5	89	60	235	200	5,51	1	-

\* SDR 11

## 2.02.03 Reduktionen kurz • Reducers short

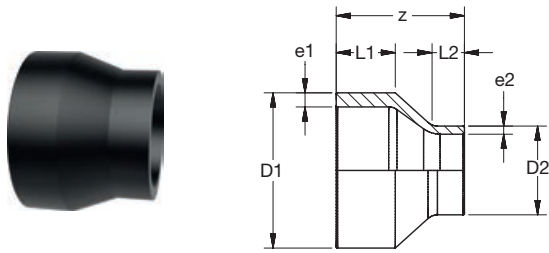

25.91.03.101 PE100 Reduktion kurz **SDR11** schwarz  
PE100 Reducer short **SDR11** black

Teil / Item	D1-D2 [mm]	e1 [mm]	e2 [mm]	L1 [mm]	L2 [mm]	z [mm]	KG	VE1	VE2
2325 0706 35	<b>25-20</b>	2,3	1,9	12	12	37	0,010	10	120
2325 0806 35	<b>32-20</b>	3,0	1,9	12	12	43	0,010	10	120
2325 0807 15	<b>32-25</b>	3,0	2,3	16	14	38	0,010	10	120
2325 0906 35	<b>40-20</b>	3,7	1,9	12	12	50	0,020	10	120
2325 0907 15	<b>40-25</b>	3,7	2,3	19	14	47	0,016	10	120
2325 0908 15	<b>40-32</b>	3,7	3,0	19	15	39	0,016	10	40
2325 1007 15	<b>50-25</b>	4,6	2,3	19	17	53	0,027	10	250
2325 1008 15	<b>50-32</b>	4,6	3,0	18	14	44	0,029	10	200
2325 1009 15	<b>50-40</b>	4,6	3,7	20	19	46	0,029	10	200
2325 1108 15	<b>63-32</b>	5,8	3,0	23	22	63	0,052	5	120
2325 1109 15	<b>63-40</b>	5,8	3,7	24	18	58	0,052	5	120
2325 1110 15	<b>63-50</b>	5,8	4,6	25	20	54	0,059	5	140
2325 1209 35	<b>75-40</b>	6,9	3,7	29	22	70	0,074	2	52
2325 1210 35	<b>75-50</b>	6,9	4,6	28	23	71	0,081	2	18
2325 1211 35	<b>75-63</b>	6,9	5,8	29	31	70	0,10	2	20
2325 1310 15	<b>90-50</b>	8,2	4,6	26	22	73	0,12	2	16
2325 1311 15	<b>90-63</b>	8,2	5,8	29	24	71	0,13	2	60
2325 1312 35	<b>90-75</b>	8,2	6,9	33	33	80	0,16	2	60
2325 1410 35	<b>110-50</b>	10,0	4,6	33	29	90	0,21	2	30
2325 1411 15	<b>110-63</b>	10,0	5,8	42	23	91	0,26	2	30
2325 1412 35	<b>110-75</b>	10,0	6,9	34	35	90	0,25	2	8
2325 1413 15	<b>110-90</b>	10,0	8,2	40	28	88	0,27	2	24
2325 1511 35	<b>125-63</b>	11,4	5,8	40	34	100	0,30	2	30
2325 1512 15	<b>125-75</b>	11,4	6,9	48	31	103	0,32	2	8
2325 1513 15	<b>125-90</b>	11,4	8,2	38	30	100	0,39	2	24
2325 1514 35	<b>125-110</b>	11,4	10,0	40	48	100	0,40	2	16
2325 1612 35	<b>140-75</b>	12,7	6,9	49	37	110	0,46	2	8
2325 1613 35	<b>140-90</b>	12,7	8,2	45	28	126	0,44	2	8
2325 1614 35	<b>140-110</b>	12,7	10,0	45	34	126	0,50	2	8
2325 1615 35	<b>140-125</b>	12,7	11,4	45	42	128	0,55	2	8
2325 1713 35	<b>160-90</b>	14,6	8,2	53	37	160	0,67	2	8
2325 1714 15	<b>160-110</b>	14,6	10,0	50	39	125	0,74	2	8
2325 1715 35	<b>160-125</b>	14,6	11,4	54	45	120	0,70	2	8
2325 1716 15	<b>160-140</b>	14,6	12,7	44	43	98	0,81	2	10
2325 1813 35	<b>180-90</b>	16,4	8,2	59	37	130	0,99	1	8
2325 1814 35	<b>180-110</b>	16,4	10,0	60	40	130	0,99	1	8
2325 1815 15	<b>180-125</b>	16,4	11,4	62	42	152	1,05	1	8
2325 1816 35	<b>180-140</b>	16,4	12,7	59	46	130	0,97	1	8
2325 1817 15	<b>180-160</b>	16,4	14,6	60	55	131	1,21	1	12
2325 1915 15	<b>200-125</b>	18,2	11,6	60	45	160	1,35	1	8
2325 1916 35	<b>200-140</b>	18,2	12,7	60	48	140	1,26	1	8
2325 1917 15	<b>200-160</b>	18,2	14,6	60	54	140	1,52	1	8
2325 1920 35	<b>200-180</b>	18,2	16,4	60	61	140	1,42	1	10
2325 2014 15	<b>225-110</b>	20,5	10,0	68	37	190	1,81	1	2
2325 2016 35	<b>225-140</b>	20,5	12,7	65	57	160	1,80	1	5
2325 2017 15	<b>225-160</b>	20,5	14,8	65	50	190	2,03	1	2
2325 2018 15	<b>225-180</b>	20,5	16,4	65	55	190	2,05	1	2
2325 2019 35	<b>225-200</b>	20,5	18,2	71	71	160	1,90	1	3

Teil / Item	D1-D2 [mm]	e1 [mm]	e2 [mm]	L1 [mm]	L2 [mm]	z [mm]	KG	VE1	VE2
2325 2117 15	<b>250-160</b>	22,8	14,6	70	50	210	2,65	1	2
2325 2118 15	<b>250-180</b>	22,8	16,4	70	55	200	2,73	1	2
2325 2119 15	<b>250-200</b>	22,8	18,2	70	60	200	2,96	1	2
2325 2120 15	<b>250-225</b>	22,8	20,5	70	65	200	3,03	1	2
2325 2218 15	<b>280-180</b>	25,4	16,4	70	54	213	3,64	1	3
2325 2219 15	<b>280-200</b>	25,4	18,2	80	60	220	3,81	1	3
2325 2220 15	<b>280-225</b>	25,4	20,5	80	65	220	3,90	1	3
2325 2221 15	<b>280-250</b>	25,4	22,7	80	70	220	4,29	1	5
2325 2319 35	<b>315-200</b>	28,6	18,2	95	85	230	5,10	1	2
2325 2320 15	<b>315-225</b>	28,6	20,5	90	64	245	5,19	1	2
2325 2321 15	<b>315-250</b>	28,6	22,7	90	70	245	5,56	1	3
2325 2322 15	<b>315-280</b>	28,6	25,5	90	80	245	5,77	1	4
2325 2420 35	<b>355-225</b>	32,2	20,5	57	40	140	4,70	1	-
2325 2421 15	<b>355-250</b>	32,2	22,7	95	70	265	7,19	1	-
2325 2422 15	<b>355-280</b>	32,2	25,4	95	80	270	7,50	1	-
2325 2423 15	<b>355-315</b>	32,2	28,6	95	90	270	8,03	1	-
2325 2522 15	<b>400-280</b>	36,6	25,4	105	80	295	9,77	1	-
2325 2523 15	<b>400-315</b>	36,6	28,6	105	90	300	10,5	1	-
2325 2524 15	<b>400-355</b>	36,6	32,2	105	95	295	10,9	1	-
2325 2623 35	<b>450-315</b>	40,9	28,6	56	40	168	7,82	1	-
2325 2624 35	<b>450-355</b>	40,9	32,2	52	43	143	8,45	1	-
2325 2625 35	<b>450-400</b>	40,9	36,4	60	57	143	7,60	1	-
2325 2724 35	<b>500-355</b>	45,4	32,2	57	38	161	9,30	1	-
2325 2725 35	<b>500-400</b>	45,4	36,3	57	58	160	9,60	1	-
2325 2726 35	<b>500-450</b>	45,4	41,0	60	40	120	9,80	1	-
2325 2825 35	<b>560-400</b>	50,8	36,6	72	37	196	15,9	1	-
2325 2826 35	<b>560-450</b>	50,8	40,9	79	60	196	14,7	1	-
2325 2827 35	<b>560-500</b>	50,8	45,5	77	75	177	14,8	1	-
2325 2926 35	<b>630-450</b>	57,2	40,9	60	40	200	21,3	1	-
2325 2927 35	<b>630-500</b>	57,2	45,5	67	40	150	21,1	1	-
2325 2928 35	<b>630-560</b>	57,2	51,0	64	40	130	19,2	1	-

## 2.02.03 Reduktionen kurz • Reducers short

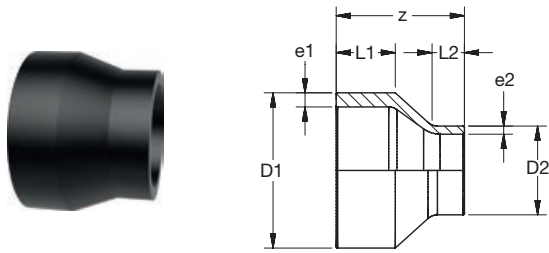

25.91.03.061 PE100 Reduktion kurz **SDR17** schwarz  
PE100 Reducer short **SDR17** black

Teil / Item	D1-D2 [mm]	e1 [mm]	e2 [mm]	L1 [mm]	L2 [mm]	z [mm]	KG	VE1	VE2
2326 1009 35	<b>50-40</b>	3,0	2,4	20	19	46	0,022	10	280
2326 1108 35	<b>63-32</b>	3,8	1,9	23	22	63	0,033	5	120
2326 1109 35	<b>63-40</b>	3,8	2,4	24	18	58	0,038	5	120
2326 1110 35	<b>63-50</b>	3,8	3,0	25	20	54	0,040	5	140
2326 1209 35	<b>75-40</b>	4,5	2,4	29	22	70	0,051	2	52
2326 1210 35	<b>75-50</b>	4,5	3,0	28	23	71	0,055	2	18
2326 1211 35	<b>75-63</b>	4,5	3,8	29	31	70	0,062	2	20
2326 1310 15	<b>90-50</b>	5,4	4,6*	26	22	73	0,10	2	16
2326 1311 15	<b>90-63</b>	5,4	5,8*	29	24	71	0,12	2	60
2326 1312 35	<b>90-75</b>	5,4	4,5	33	33	80	0,10	2	60
2326 1410 35	<b>110-50</b>	6,6	5,4	33	29	90	0,21	2	30
2326 1411 15	<b>110-63</b>	6,6	3,8	42	23	91	0,20	2	30
2326 1412 15	<b>110-75</b>	6,6	4,5	34	35	90	0,16	2	8
2326 1413 15	<b>110-90</b>	6,6	5,4	40	28	88	0,18	2	24
2326 1511 35	<b>125-63</b>	7,4	6,6	40	34	100	0,20	2	8
2326 1512 15	<b>125-75</b>	7,4	4,5	48	31	103	0,27	2	8
2316 1513 15	<b>125-90</b>	7,4	5,4	38	30	100	0,27	2	8
2326 1514 35	<b>125-110</b>	7,4	6,6	40	48	100	0,27	2	16
2326 1612 35	<b>140-75</b>	8,3	4,5	49	37	110	0,29	2	8
2326 1613 35	<b>140-90</b>	8,3	5,4	45	28	126	0,30	2	8
2326 1614 35	<b>140-110</b>	8,3	6,6	45	34	126	0,33	2	8
2326 1615 35	<b>140-125</b>	8,3	7,4	45	42	128	0,38	2	8
2326 1713 35	<b>160-90</b>	9,5	5,4	53	37	160	0,50	2	8
2326 1714 15	<b>160-110</b>	9,5	6,6	50	39	125	0,53	2	8
2326 1715 35	<b>160-125</b>	9,5	7,4	54	45	120	0,48	2	8
2326 1716 15	<b>160-140</b>	9,5	8,3	44	43	98	0,61	2	10
2326 1813 35	<b>180-90</b>	10,7	5,4	59	37	130	0,69	1	8
2326 1814 35	<b>180-110</b>	10,7	6,6	60	40	130	0,77	1	8
2326 1815 15	<b>180-125</b>	10,7	7,4	62	42	152	0,72	1	8
2326 1816 35	<b>180-140</b>	10,7	8,3	59	46	130	0,65	1	8
2326 1817 15	<b>180-160</b>	10,7	9,5	60	55	131	1,03	1	12
2326 1915 15	<b>200-125</b>	11,9	7,4	60	45	160	1,30	1	8
2326 1916 35	<b>200-140</b>	11,9	8,3	60	48	140	0,86	1	8
2326 1917 15	<b>200-160</b>	11,9	9,5	60	54	140	1,01	1	8
2326 1918 35	<b>200-180</b>	11,9	10,7	60	61	140	0,97	1	10
2326 2014 15	<b>225-110</b>	13,4	6,6	68	37	190	1,55	1	3
2326 2016 35	<b>225-140</b>	13,4	8,3	65	57	160	1,80	1	5
2326 2017 15	<b>225-160</b>	13,4	9,5	65	50	190	1,40	1	5
2326 2018 15	<b>225-180</b>	13,4	10,7	65	55	190	1,26	1	3
2326 2019 35	<b>225-200</b>	13,4	11,9	71	71	160	1,42	1	3
2326 2117 15	<b>250-160</b>	14,8	9,5	70	50	210	2,32	1	2
2326 2118 15	<b>250-180</b>	14,8	10,7	70	55	200	2,37	1	2
2326 2119 15	<b>250-200</b>	14,8	11,9	70	60	200	2,55	1	2
2326 2120 15	<b>250-225</b>	14,8	13,4	70	65	200	2,54	1	2
2326 2218 15	<b>280-180</b>	16,6	10,7	70	54	213	3,26	1	3
2326 2219 15	<b>280-200</b>	16,6	11,9	80	60	220	3,45	1	3
2326 2220 15	<b>280-225</b>	16,6	13,4	80	65	220	3,49	1	3
2326 2221 15	<b>280-250</b>	16,6	14,8	80	70	220	3,53	1	5

Teil / Item	D1-D2 [mm]	e1 [mm]	e2 [mm]	L1 [mm]	L2 [mm]	z [mm]	KG	VE1	VE2
2326 2319 35	<b>315-200</b>	18,7	11,9	95	85	230	3,40	1	2
2326 2320 15	<b>315-225</b>	18,7	13,4	90	64	245	4,88	1	2
2326 2321 15	<b>315-250</b>	18,7	14,8	90	70	245	4,79	1	3
2326 2322 15	<b>315-280</b>	18,7	16,6	90	80	245	4,82	1	4
2326 2420 35	<b>355-225</b>	21,1	13,4	57	40	140	6,10	1	
2326 2421 15	<b>355-250</b>	21,1	14,8	95	70	265	6,16	1	
2326 2422 15	<b>355-280</b>	21,1	16,6	95	80	270	6,56	1	
2326 2423 15	<b>355-315</b>	21,1	18,7	95	90	270	6,71	1	
2326 2522 15	<b>400-280</b>	23,7	16,6	105	80	295	8,67	1	
2326 2523 15	<b>400-315</b>	23,7	18,7	105	90	300	8,93	1	
2326 2524 15	<b>400-355</b>	23,7	16,6	105	95	295	9,06	1	
2326 2623 35	<b>450-315</b>	26,7	18,7	56	40	168	6,42	1	
2326 2624 35	<b>450-355</b>	26,7	21,1	52	43	143	5,48	1	
2326 2625 35	<b>450-400</b>	26,7	23,7	60	57	143	5,80	1	
2326 2724 35	<b>500-355</b>	29,7	21,1	57	38	161	7,60	1	
2326 2725 35	<b>500-400</b>	29,7	23,7	57	58	160	6,60	1	
2326 2726 35	<b>500-450</b>	29,7	26,7	60	40	120	6,62	1	
2326 2825 35	<b>560-400</b>	33,2	23,7	72	37	196	10,5	1	
2326 2826 35	<b>560-450</b>	33,2	26,7	79	60	196	10,8	1	
2326 2827 35	<b>560-500</b>	33,2	29,7	77	75	177	11,4	1	
2326 2926 35	<b>630-450</b>	37,4	26,7	60	40	200	16,6	1	
2326 2927 35	<b>630-500</b>	37,4	29,7	67	40	150	13,6	1	
2326 2928 35	<b>630-560</b>	37,4	33,2	64	40	130	12,5	1	
2326 3028 35	<b>710-560</b>	42,1	33,2	67	49	195	15,7	1	
2326 3029 35	<b>710-630</b>	42,1	37,4	60	46	144	15,3	1	
2326 3130 35	<b>800-710</b>	47,4	42,1	68	52	167	25,1	1	
2326 3231 35	<b>900-800</b>	53,3	47,4	68	43	156	25,1	1	
2326 3332 35	<b>1000-900</b>	59,3	53,3	67	75	190	34,5	1	

## 2.02.04 Übergänge kurz • Transitions short

### PE100 Übergang kurze Ausführung SDR11

Betriebsdruck 8 bar (für Wasser bei 20°C)

### PE100 adaptor socket short SDR11

Operating pressure 8 bar (for water of 20°C)

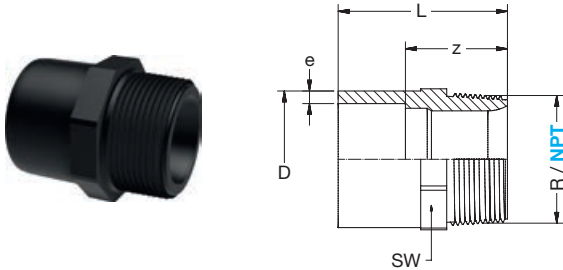

25.91.07.103 PE100 Übergang kurz **AG-keg SDR11** schwarz  
PE100 Transition short **male-thread-con SDR11** black

Teil / Item	D x R [mm x Inch]	Thread	e [mm]	L [mm]	z [mm]	SW [mm]	KG	VE1	VE2
2615 0773 15	25 x 1/2	m	2,3	45	29	26	0,012	5	130
2615 0775 15	25 x 3/4	m	2,3	47	31	26	0,013	5	100
2615 0875 15	32 x 3/4	m	3,0	47	31	34	0,017	10	100
2615 0876 15	32 x 1	m	3,0	48	35	34	0,021	10	50
2615 0976 15	40 x 1	m	3,7	58	36	44	0,032	10	60
2615 0977 15	40 x 1 1/4	m	3,7	59	39	44	0,034	10	100
2615 1077 15	50 x 1 1/4	m	4,6	63	43	49	0,050	10	60
2615 1078 15	50 x 1 1/2	m	4,6	65	46	49	0,056	10	60
2615 1178 15	63 x 1 1/2	m	5,8	72	52	65	0,082	10	60
2615 1180 15	63 x 2	m	5,8	76	52	65	0,090	10	60

25.91.07.103 PE100 Übergang kurz **AG-NPT SDR11** schwarz  
PE100 Transition short **male-thread-NPT SDR11** black

Teil / Item	D x NPT [mm x Inch]	Thread	e [mm]	L [mm]	z [mm]	SW [mm]	KG	VE1	VE2
2615 0876 U5	32 x 1	m	3,0	48	35	34	0,021	10	50
2615 0977 U5	40 x 1 1/4	m	3,7	59	39	44	0,034	10	100
2615 1078 U5	50 x 1 1/2	m	4,6	65	46	49	0,056	10	60
2615 1180 U5	63 x 2	m	5,8	76	52	65	0,090	10	60

## 2.02.05 Flanschverbindung kurz • Flange connection short

### Vorschweißbund (V-Bund) kurz in gerillter Ausführung für den Einsatz von Flachdichtungen.

Weitere Informationen zu Flanschen und Dichtungen finden Sie unter 6. Zubehör.

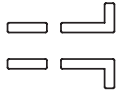

### Flange adaptor spigot short grooved for the use of flat-gaskets.

More information about flanges and gaskets see 6. Accessories.

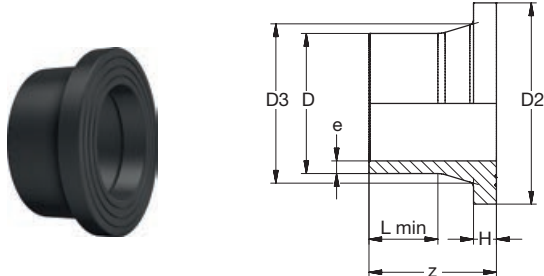

25.80.01.101 PE100 V-Bund kurz gerillt **SDR11** schwarz  
PE100 Flange adaptor spigot short grooved **SDR11** black

Teil / Item	D [mm]	e [mm]	D2 [mm]	D3 [mm]	H [mm]	L min [mm]	z [mm]	KG	VE1	VE2
2335 07F0 15	25	2,3	58	33	9	18	35	0,031	10	170
2335 08F0 15	32	3,0	68	40	10	18	35	0,043	10	140
2335 09F0 15	40	3,7	78	50	11	18	40	0,064	10	150
2335 10F0 15	50	4,6	88	61	12	18	60	0,095	10	90
2335 11F0 15	63	5,8	102	75	14	18	78	0,16	2	12
2335 12F0 15	75	6,9	122	89	16	28	78	0,25	2	36
2335 13F0 15	90	8,2	138	105	17	29	88	0,35	2	24
2335 14F0 15	110	10,0	158	125	18	41	100	0,54	2	12
2335 15F0 15	125	11,4	158	132	25	48	110	0,66	2	10
2335 16F0 15	140	12,7	188	155	25	54	116	0,97	1	8
2335 17F0 15	160	14,6	212	175	25	55	127	1,25	1	6
2335 18F0 15	180	16,4	212	180	30	60	138	1,46	1	4
2335 19F0 15	200	18,2	268	232	32	67	145	2,48	1	3
2335 20F0 15	225	20,5	268	235	32	72	148	2,52	1	3
2335 21F0 15	250	22,7	320	285	35	77	158	3,86	1	2
2335 22F0 15	280	25,4	320	291	35	81	180	4,29	1	2
2335 23F0 15	315	28,6	370	335	35	95	188	6,00	1	-
2335 24F0 15	355	32,2	430	373	40	30	217	8,75	1	-
2335 25F0 15	400	36,3	482	427	46	42	220	12,0	1	-
2335 26F0 15	450	40,9	585	514	60	14	300	13,8	1	-
2335 27F0 15	500	45,4	585	530	60	24	300	24,0	1	-
2335 28F0 35	560	50,8	685	615	60	10	120	18,5	1	-
2335 29F0 15	630	57,2	685	642	60	46	310	21,6	1	-
2335 30F0 35	710	64,5	auf Anfrage / by request						1	-
2335 31F0 35	800	72,6	auf Anfrage / by request						1	-
2335 32F0 35	900	81,7	auf Anfrage / by request						1	-
2335 33F0 35	1000	90,8	auf Anfrage / by request						1	-

25.80.01.061 PE100 V-Bund kurz gerillt **SDR17** schwarz  
PE100 Flange adaptor spigot short grooved **SDR17** black

Teil / Item	D [mm]	e [mm]	D2 [mm]	D3 [mm]	H [mm]	L min [mm]	z [mm]	KG	VE1	VE2
2336 10F0 35	50	2,9	88	61	12	18	60	0,070	10	90
2336 11F0 35	63	3,8	102	75	14	18	78	0,11	2	12
2336 12F0 15	75	4,5	122	89	16	28	78	0,21	2	36
2336 13F0 15	90	5,4	138	105	17	29	88	0,30	2	24
2336 14F0 15	110	6,6	158	125	18	41	100	0,46	2	12
2336 15F0 15	125	7,4	158	132	18	48	110	0,45	2	10
2336 16F0 15	140	8,3	188	155	18	54	116	0,69	1	8
2336 17F0 15	160	9,5	212	175	18	55	127	0,91	1	6
2336 18F0 15	180	10,7	212	180	20	60	138	0,98	1	4
2336 19F0 15	200	11,9	268	232	24	67	145	1,80	1	3
2336 20F0 15	225	13,4	268	235	24	72	148	1,77	1	3
2336 21F0 15	250	14,8	320	285	25	77	158	2,72	1	2
2336 22F0 15	280	16,6	320	291	25	81	180	3,02	1	2
2336 23F0 15	315	18,7	370	335	25	95	188	4,24	1	-
2336 24F0 15	355	21,1	430	373	30	30	217	6,27	1	-
2336 25F0 15	400	23,7	482	427	33	42	220	8,20	1	-
2336 26F0 15	450	26,7	585	514	46	14	300	9,80	1	-
2336 27F0 15	500	29,7	585	530	46	24	300	17,0	1	-
2336 28F0 35	560	33,2	685	615	50	10	120	12,3	1	-
2336 29F0 15	630	37,4	685	642	50	46	310	12,8	1	-
2336 30F0 35	710	42,1	685	642	50	14	300	18,9	1	-
2336 31F0 35	800	47,4	685	642	50	24	300	24,3	1	-
2336 32F0 35	900	53,3	685	642	50	10	120	33,3	1	-
2336 33F0 35	1000	59,3	685	642	60	46	310	43,0	1	-

**Zubehör Flanschverbindung PE (V-Bund) • Accessories Flange Connection PE (V-Bund)**

 Losflansch  
Flange loose

D [mm]	DN [mm]	PP-St		St beschichtet St coated	PP-GGG	PP-St	
		DIN/EN				ANSI	
		PN10/16	PN10	PN16	PN10	150 lbs	
25	20	9141 07E1 15					9141 07A2 38
32	25	9141 08E1 15					9141 08A2 38
40	32	9141 09E1 15					9141 09A2 38
50	40	9141 10E1 15					9141 10A2 38
63	50	9141 11E1 15				9151 11A2 25	
75	65	9141 12E1 15					9141 12A2 38
90	80	9143 13E1 15				9153 13A2 25	
110	100	9143 14E1 15				9153 14A2 25	
125	100	9143 15E1 15					9143 14A2 38
140	125	9143 16E1 15					
160	150	9143 17E1 15				9153 17A2 25	
180	150	9143 18E1 15				9153 18A2 35	
200	200		9143 19E2 15	9143 19E3 35	9153 19A2 25		
225	200		9143 20E2 15	9143 20E3 35	9153 19A2 25		
250	250		9143 21E2 15	9143 21E3 35	9153 21A2 25		
280	250		9143 22E2 15	9143 22E3 35			
315	300		9143 23E2 15	9143 23E3 35	9153 23A2 25		
355	350		9143 24E2 15	9143 24E3 35		9143 24A2 38	
400	400		9143 25E2 15	9143 25E3 35		9143 25A2 38	
450	500		9143 26E2 35				
500	500		9143 27E2 35			9143 27A2 38	
560	600		9143 28E2 35				
630	600		9143 29E2 35				
710	700			9113 30E2 05			
800	800			9113 31E2 05			
900	900			9113 32E2 05			
1000	1000			9113 33E2 05			

 Blindflansch  
Flange blind

 Flachdichtung mit Stahleinlage  
Flat gasket with steel-inlay

D [mm]	DN [mm]	PP-St		ANSI	EPDM		NBR	
		DIN/EN		150 lbs	Wasser / Water		Gas / Gas	
		PN10/16	PN10		SDR11	SDR17	SDR11	SDR17
25	20	9144 07E1 35		9144 07A2 38	9203 07F1 35		9203 07F2 35	
32	25	9144 08E1 35		9144 08A2 38	9203 08F1 35		9203 08F2 35	
40	32	9144 09E1 35		9144 09A2 38	9203 09F1 35		9203 09F2 35	
50	40	9144 10E1 35		9144 10A2 38	9203 10F1 35		9203 10F2 35	
63	50	9144 11E1 35		9144 11A2 38	9203 11F1 35		9203 11F2 35	
75	65	9144 12E1 35		9144 12A2 38	9203 12F1 35	9204 12F1 35	9203 12F2 35	9204 12F2 35
90	80	9144 13E1 35		9144 13 A2 38	9203 13F1 35	9204 13F1 35	9203 13F2 35	9204 13F2 35
110	100	9144 14E1 35		9144 14 A2 38	9203 14F1 35	9204 14F1 35	9203 14F2 35	9204 14F2 35
125	100	9144 14E1 35			9203 15F1 35	9204 15F1 35	9203 15F2 35	9204 15F2 35
140	125	9144 16E1 35			9203 16F1 35	9204 16F1 35	9203 16F2 35	9204 16F2 35
160	150	9144 17E1 35		9144 17A2 38	9203 17F1 35	9204 17F1 35	9203 17F2 35	9204 17F2 35
180	150	9144 17E1 35			9203 18F1 35	9204 18F1 35	9203 18F2 35	9204 18F2 35
200	200		9144 19E2 35	9144 19A2 38	9203 19F1 35	9204 19F1 35	9203 19F2 35	9204 19F2 35
225	200		9144 19E2 35		9203 20F1 35	9204 20F1 35	9203 20F2 35	9204 20F2 35
250	250		9144 21E2 35	9144 21A2 38	9203 21F1 35	9204 21F1 35	9203 21F2 35	9204 21F2 35
280	250		9144 21E2 35		9203 22F1 35	9204 22F1 35	9203 22F2 35	9204 22F2 35
315	300		9144 23E2 35	9144 23A2 38	9203 23F1 35	9204 23F1 35	9203 23F2 35	9204 23F2 35
355	350		9144 24E2 35		9203 24F1 35	9204 24F1 35	9203 24F2 35	9204 24F2 35
400	400		9144 25E2 35		9203 25F1 35	9204 25F1 35	9203 25F2 35	9204 25F2 35
450	500				9203 26F1 35	9204 26F1 35	9203 26F2 35	9204 26F2 35
500	500				9203 27F1 35	9204 27F1 35	9203 27F2 35	9204 27F2 35
560	600				9203 28F1 35	9204 28F1 35	9203 28F2 35	9204 28F2 35
630	600				9203 29F1 35	9204 29F1 35	9203 29F2 35	9204 29F2 35

## 2.03 E-Formteile • E-Fittings

E-Formteile = Formteile für Heizwendel-Muffen-Schweißung, monofilar.

E-Fittings = Fittings for electrofusion socket-welding, monofilar.

### PE100 Heizwendel-Muffen-Schweiß-Formteile

Die Formteile besitzen einen Barcode und können somit mit allen modernen Schweißgeräten mit Barcode-Leseeinrichtungen verschweißt werden. Bei älteren Schweißgeräten werden die Schweißdaten manuell eingegeben. Alle Formteile besitzen einen Schweißindikator.

### PE100 Electrofusion socket-welding-fittings

The fittings are equipped with a barcode and can be welded by any modern welding machine coming with a barcoder reader. Older machines have to put in the welding dates manually. All fittings are provided with a welding control indicator.

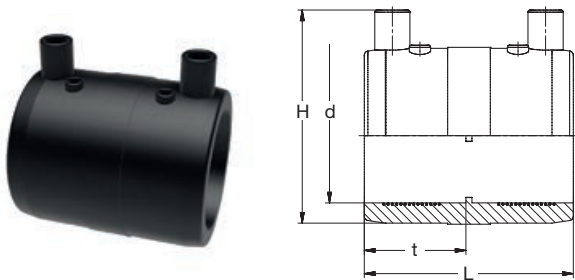

39103 PE100 E-Muffe **SDR11** schwarz  
PE100 E-Socket **SDR11** black

Teil / Item	d [mm]	t [mm]	L [mm]	H [mm]	kg	VE1	VE2
2HM4 0600 35	20	34,0	70	53	0,040	1	60
2HM4 0700 35	25	34,0	70	58	0,040	1	50
2HM4 0800 35	32	34,0	70	65	0,060	1	40
2HM4 0900 35	40	41,0	84	75	0,10	1	30
2HM4 1000 35	50	42,0	87	86	0,14	1	20
2HM4 1100 35	63	47,0	97	100	0,16	1	18
2HM4 1200 35	75	59,5	122	115	0,34	1	24
2HM4 1300 35	90	71,0	145	128	0,48	1	32
2HM4 1400 25	110	76,5	155	150	0,62	1	22
2HM4 1500 25	125	81,5	164	167	0,94	1	16
2HM4 1600 35	140	96,0	195	180	1,08	1	30
2HM4 1700 25	160	97,0	197	205	1,38	1	24
2HM4 1800 35	180	99,5	202	222	1,86	1	18
2HM4 1900 35	200	99,5	202	245	1,98	1	14
2HM4 2000 35	225	90,0	180	288	3,54	1	24
2HM4 2100 35	250	110,0	220	315	4,02	1	22
2HM4 2200 35	280	110,0	220	355	8,14	1	12
2HM4 2300 35	315	110,0	220	400	11,3	1	10
2HM4 2400 35	355	130,0	260	450	15,8	1	-
2HM4 2500 35	400	145,0	290	500	19,9	1	-
2HM4 2600 35	450	170,0	340	555	29,1	1	-
2HM4 2700 35	500	180,0	360	600	34,1	1	-
2HM4 2800 35	560	200,0	400	710	50,9	1	-
2HM4 2900 35	630	220,0	440	800	70,3	1	-
2HM4 3000 35	710	250,0	500	812	91,4	1	-
2HM4 3100 35	800	250,0	500	900	109,0	1	-
2HM4 3200 35	900	270,0	540	1000		1	-
2HM4 3300 35	1000	325,0	650	1370		1	-

39063 PE100 E-Muffe **SDR17** schwarz  
PE100 E-Socket **SDR17** black

Teil / Item	d [mm]	t [mm]	L [mm]	H [mm]	kg	VE1	VE2
2HM6 1300 35	90	71,0	145	128	0,40	1	32
2HM6 1400 35	110	76,5	155	150	0,64	1	22
2HM6 1500 35	125	81,5	164	167	1,00	1	16
2HM6 1600 35	140	96,0	195	180	1,10	1	30
2HM6 1700 35	160	97,0	197	205	1,36	1	24
2HM6 1800 35	180	99,5	202	222	1,84	1	18
2HM6 1900 35	200	99,5	202	245	1,94	1	14
2HM6 2000 35	225	90,0	180	288	2,24	1	24
2HM6 2100 35	250	110,0	220	315	2,30	1	22
2HM6 2200 35	280	110,0	220	355	4,04	1	12
2HM6 2300 35	315	110,0	220	400	5,44	1	10
2HM6 2400 35	355	130,0	260	450	7,18	1	-
2HM6 2500 35	400	145,0	290	500	10,8	1	-
2HM6 2600 35	450	170,0	340	555	13,2	1	-
2HM6 2700 35	500	180,0	360	600	19,5	1	-
2HM6 2800 35	560	200,0	400	710	28,5	1	-
2HM6 2900 35	630	220,0	440	800	39,3	1	-
2HM6 3000 35	710	250,0	500	812	51,9	1	-
2HM6 3100 35	800	250,0	500	900	68,0	1	-
2HM6 3200 35	900	270,0	540	1000	65,0	1	-
2HM6 3300 35	1000	325,0	650	1370		1	-

## 2.03 E-Formteile • E-Fittings



PE100 E-Muffe **SDR13,6 PN12,5** schwarz

PE100 E-Socket **SDR13,6 PN12,5** black

Teil / Item	d [mm]	L [mm]	KG	VE1	VE2
2HM5 26S0 35	450	350	16,5	1	-
2HM5 27S0 35	500	359	22,0	1	-
2HM5 28S0 35	560	390	33,2	1	-
2HM5 29S0 35	630	420	46,9	1	-

Muffen Durchmesser 500, 560 + 630:

Zwei separate und elektrisch unabhängige Schweißzonen.

Lieferung mit Spanngurten um jeglicher Ausdehnung vorzubeugen.

Druckklasse von 16bar; garantiert durch den Hersteller.

Verschweißbar mit Rohr/Formteilen SDR11-26.

Sockets diameter 500, 560 + 630:

Two separate fusion zones and electrically independant.

Supplied with pre-pulled belts (no need of regulation) to avoid any expansion.

Pressure class of 16bar; guaranteed by manufacturer.

Weldability on pipe/fitting SDR11-26.

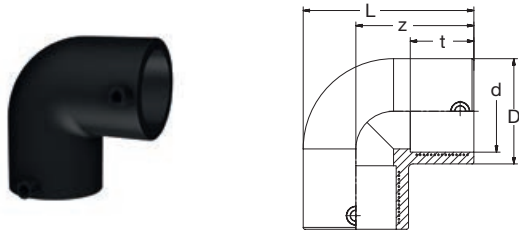

31003

PE100 E-Winkel 90° **SDR11** schwarz

PE100 E-Elbow 90° **SDR11** black

Teil / Item	d [mm]	D [mm]	L [mm]	t [mm]	z [mm]	KG	VE1	VE2
2HW4 0790 35	25	37	72,5	36,5	54,0	0,069	1	30
2HW4 0890 35	32	45	80,0	36,0	57,5	0,087	1	20
2HW4 0990 35	40	54	95,0	42,0	68,0	0,16	1	20
2HW4 1090 35	50	67	110,5	47,0	77,0	0,23	1	15
2HW4 1190 35	63	84	130,0	53,0	88,0	0,39	1	8
2HW4 1290 35	75	92	145,0	58,0	99,0	0,50	1	6
2HW4 1390 35	90	118	180,0	67,0	122,0	0,96	1	14
2HW4 1490 35	110	139	209,5	79,5	140,0	1,31	1	10
2HW4 1590 35	125	158	211,0	85,0	152,0	1,77	1	8
2HW4 1790 35	160	197	298,5	100,0	200,0	4,20	1	8
2HW4 1890 35	180	220	323,0	100,0	213,0	5,70	1	5
2HW4 1990 35	200	240	245,0	125,0	250,0	7,96	1	-

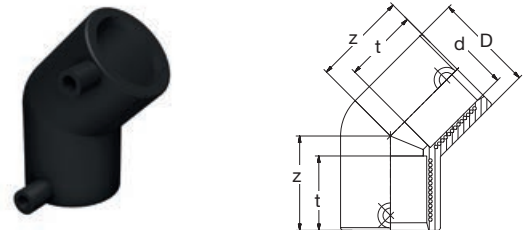

31503

PE100 E-Winkel 45° **SDR11** schwarz

PE100 E-Elbow 45° **SDR11** black

Teil / Item	d [mm]	D [mm]	t [mm]	z [mm]	KG	VE1	VE2
2HW4 0845 35	32	45,0	36,0	46,5	0,08	1	30
2HW4 0945 35	40	56,6	44,0	54,0	0,14	1	20
2HW4 1045 35	50	63,0	46,0	62,0	0,22	1	16
2HW4 1145 35	63	80,5	54,0	67,5	0,37	1	8
2HW4 1245 35	75	96,0	48,0	70,5	0,41	1	6
2HW4 1345 35	90	120,0	68,0	98,0	0,84	1	20
2HW4 1445 35	110	140,0	83,0	114,5	1,10	1	12
2HW4 1545 35	125	170,0	85,0	122,0	1,54	1	8
2HW4 1745 35	160	198,5	99,0	136,0	2,14	1	12
2HW4 1845 35	180	215,0	106,0	160,0	2,45	1	6
2HW4 1945 35	200	240,0	121,0	185,0	6,10	1	-

## 2.03 E-Formteile • E-Fittings

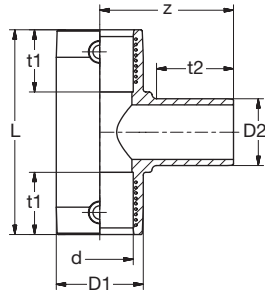

32003 PE100 E-T-Stück 90° mit Schweißstutzen **SDR11** schwarz  
PE100 E-Tee 90° with spigot **SDR11** black

Teil / Item	d [mm]	D [mm]	L [mm]	T1 [mm]	T2 [mm]	z [mm]	KG	VE1	VE2
2HT4 0790 35	25	37	100	37,5	46,0	68,5	0,090	1	30
2HT4 0890 35	32	44	110	37,5	50,0	75,0	0,14	1	25
2HT4 0990 35	40	54	133	44,5	53,5	85,0	0,23	1	16
2HT4 1090 35	50	65	151	46,5	59,5	100,0	0,33	1	10
2HT4 1190 35	63	80	177	56,5	67,0	115,0	0,53	1	6
2HT4 1290 35	75	95	196	58,0	72,0	130,0	0,61	1	4
2HT4 1390 35	90	120	244	70,0	85,0	120,0	1,10	1	10
2HT4 1490 35	110	139	282	81,5	89,5	177,0	1,68	1	7
2HT4 1590 35	125	159	315	88,0	95,0	191,5	2,45	1	5
2HT4 1790 35	160	200	340	115,0	110,0	215,0	3,86	1	8
2HT4 1890 35	180	223	360	115,0	160,0	283,0	4,26	1	4
2HT4 1990 35	200	235	400	115,0	115,0	275,0	9,18	1	-

**Anmerkung/Remark:**

Mittlerer Abgang ist ein Stutzenende in langer Ausführung.  
Branch side is a long spigot.

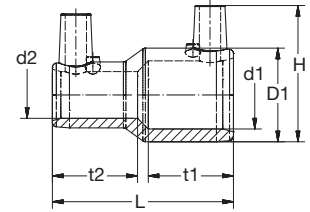

39003 PE100 E-Reduktion **SDR11** schwarz  
PE100 E-Reducer **SDR11** black

Teil / Item	d1-d2 [mm]	D1 [mm]	L [mm]	H [mm]	t1 [mm]	t2 [mm]	KG	VE1	VE2
2HR4 0706 35	25-20	34	82	54	43	38	0,025	1	-
2HR4 0806 35	32-20	42	90	62	43	39	0,058	1	30
2HR4 0807 35	32-25	44	85	64	40	40	0,07	1	20
2HR4 0908 35	40-32	52	90	70	42	43	0,09	1	20
2HR4 1008 35	50-32	63	98	82	47	42	0,12	1	20
2HR4 1009 35	50-40	68	98	86	48	44	0,13	1	10
2HR4 1108 35	63-32	77	117	100	53	42	0,18	1	16
2HR4 1109 35	63-40	81	117	100	55	44	0,20	1	12
2HR4 1110 35	63-50	77	117	100	53	47	0,21	1	12
2HR4 1211 35	75-63	95	157	113	70	63	0,35	1	12
2HR4 1310 35	90-50	117	142	135	72	49	0,43	1	16
2HR4 1311 35	90-63	113	148	130	67	63	0,44	1	30
2HR4 1411 35	110-63	132	158	149	72,5	63	0,56	1	24
2HR4 1413 35	110-90	132	158	149	73,5	68	0,60	1	24
2HR4 1511 35	125-63	149	158	166	69,5	63	0,65	1	20
2HR4 1513 35	125-90	148	156	166	74	68	0,71	1	16
2HR4 1514 35	125-110	152	122	167	58	51	0,78	1	16
2HR4 1713 35	160-90	193	173	205	75	68	1,10	1	12
2HR4 1714 35	160-110	193	178	205	75	72	1,24	1	12
2HR4 1715 35	160-125	193	178	205	75	72	1,26	1	8
2HR4 1917 35	200-160						3,31	1	1
2HR4 2017 35	225-160						3,74	1	6

PE100

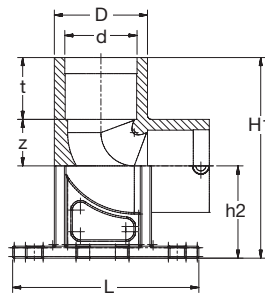

31103 PE100 E-Fußbogen 90° **SDR11** schwarz  
PE100 E-Duckfoot Elbow 90° **SDR11** black

Teil / Item	d [mm]	D [mm]	L [mm]	H1 [mm]	h2 [mm]	t [mm]	z [mm]	KG	VE1	VE2
2HF4 1390 35	90	116	245	250	115	77,0	58	2,17	1	-

## 2.04 Rohrbögen nahtlos • Pipe bends seamless

### PE100 Rohrbögen nahtlos SDR11/17 in 90°/60°/45°/30°/22°/11° schwarz

mit langen Schweißenden für Stumpf- und Heizwendel-Muffen-Schweißung

### PE100 Pipe bends seamless SDR11/17 in 90°/60°/45°/30°/22°/11° black

with long spigots for butt- and electrofusion socket-welding

#### Werkstoff

Wahlweise PE100 oder PE-RC (rissbeständig), schwarz.  
PE-RC = weiterentwickelter PE100 Werkstoff mit erhöhter Spannungsrissbeständigkeit.

#### Geometrische Eigenschaften

Außendurchmesser und Wanddicke entsprechend EN 1555 und EN 12201.  
Winkelangaben: Toleranz +/- 3°.  
Längenangaben: Minimum Maße  
 $r \approx 1,5 \times d$

#### Ausführung

Geeignet für Stumpf- und Heizwendel-Muffen-Schweißung.  
Geeignet für Gas & Trinkwasser.  
Die Bögen sind vorwiegend für den Einsatz im Tiefbau vorgesehen. Im Anlagen- bzw. Industriebau kann es bedingt durch den relativ großen Toleranzbereich beim Winkelmaß von  $\pm 3^\circ$  zu Montageproblemen kommen. Beanstandungen auf Grund dieser Gegebenheiten können wir nicht anerkennen.

Weitere Abmessungen, Radien und Gradzahlen auf Anfrage. Alternativ können die Bögen auch in PE-RC Material geliefert werden.

#### Material

Selectively PE100 or PE-RC (resistance to crack), black.  
PE-RC = further developed PE100 material with increased stress crack resistance.

#### Geometric Properties

Outside diameter and wall thickness according to EN 1555 and EN 12201.  
Angles: Tolerance +/- 3°.  
Length: minimum sizes.  
 $r \approx 1,5 \times d$

#### Type

Suitable for butt- and electrofusion-socket-welding.  
Suitable for Gas & Drinking water.  
The bends are mainly designated for underground work application. At applications for plant and industrial engineering installation problems might arise due to the relatively high tolerance range having an angular measure of  $\pm 3^\circ$ . Any claims caused by these conditions will be rejected.

Further sizes, radiuses and degrees on request. Alternatively we are able to supply the bends in PE-RC material.

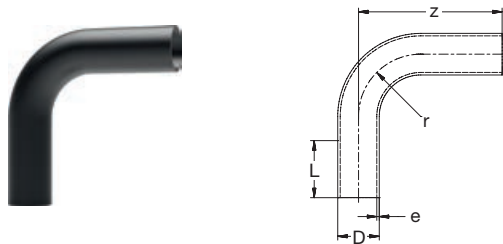

25.90.01.103 PE100 Rohrbogen 90° nahtlos lang SDR11 schwarz  
PE100 Pipe bend 90° seamless long SDR11 black

Teil / Item	D [mm]	e [mm]	L [mm]	r [mm]	z [mm]	KG	VE1	VE2
2433 1190 25	63	5,8	100	95	160	0,40	1	
2433 1290 25	75	6,9	100	113	170	0,70	1	
2433 1390 25	90	8,2	150	135	300	1,10	1	
2433 1490 25	110	10,0	150	165	380	2,10	1	
2433 1590 25	125	11,4	150	188	400	2,80	1	
2433 1690 25	140	12,7	150	210	440	3,90	1	
2433 1790 25	160	14,6	150	240	480	5,50	1	
2433 1890 25	180	16,4	150	270	530	7,60	1	
2433 1990 25	200	18,2	150	300	560	9,90	1	
2433 2090 25	225	20,5	150	338	590	13,10	1	
2433 2190 25	250	22,7	250	375	730	20,20	1	
2433 2290 25	280	25,4	250	420	750	25,70	1	
2433 2390 25	315	28,6	300	496	900	39,20	1	
2433 2490 25	355	32,2	300	560	1000	55,10	1	
2433 2590 25	400	36,3	300	637	1050	72,70	1	
2433 2690 25	450	40,9	300	711	1150	100,60	1	
2433 2790 25	500	45,4	350	783	1300	140,90	1	
2433 2890 25	560	50,8	350	877	1350	181,20	1	
2433 2990 25	630	57,2	350	965	1600	275,60	1	
2433 3090 25	710	64,5	350	1128	1900	416,20	1	
2433 3190 25	800	72,6	350	1274	2000	549,80	1	
2433 3290 25	900	81,7	400	1430	2200	763,20	1	

25.90.01.063 PE100 Rohrbogen 90° nahtlos lang SDR17 schwarz  
PE100 Pipe bend 90° seamless long SDR17 black

Teil / Item	D [mm]	e [mm]	L [mm]	r [mm]	z [mm]	KG	VE1	VE2
2434 1190 25	63	3,8	100	95	220	0,30	1	
2434 1290 25	75	4,5	100	113	260	0,50	1	
2434 1390 25	90	5,4	150	135	300	0,70	1	
2434 1490 25	110	6,6	150	165	380	1,40	1	
2434 1590 25	125	7,4	150	188	400	1,90	1	
2434 1690 25	140	8,3	150	210	440	2,60	1	
2434 1790 25	160	9,5	150	240	480	3,70	1	
2434 1890 25	180	10,7	150	270	530	5,20	1	
2434 1990 25	200	11,9	150	300	560	6,70	1	
2434 2090 25	225	13,4	150	338	590	8,80	1	
2434 2190 25	250	14,8	250	375	730	13,60	1	
2434 2290 25	280	16,6	250	420	750	17,40	1	
2434 2390 25	315	18,7	300	496	900	26,50	1	
2434 2490 25	355	21,1	300	560	1000	37,40	1	
2434 2590 25	400	23,7	300	637	1050	49,10	1	
2434 2690 25	450	26,7	300	711	1150	68,00	1	
2434 2790 25	500	29,7	350	783	1300	95,30	1	
2434 2890 25	560	33,2	350	877	1350	122,50	1	
2434 2990 25	630	37,4	350	955	1600	186,40	1	
2434 3090 25	710	42,1	350	1128	1900	281,10	1	
2434 3190 25	800	47,4	350	1274	2000	371,40	1	
2434 3290 25	900	53,3	400	1430	2200	515,20	1	

## 2.04 Rohrbögen nahtlos • Pipe bends seamless

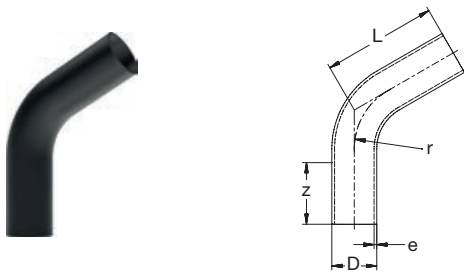

25.60.01.103 PE100 Rohrbogen 60° nahtlos lang **SDR11** schwarz  
PE100 Pipe bend 60° seamless long **SDR11** black

Teil / Item	D [mm]	e [mm]	L [mm]	r [mm]	z [mm]	KG	VE1	VE2
2433 1160 25	63	5,8	100	95	180	0,30	1	
2433 1260 25	75	6,9	100	113	220	0,60	1	
2433 1360 25	90	8,2	150	135	250	1,00	1	
2433 1460 25	110	10,0	150	165	280	1,60	1	
2433 1560 25	125	11,4	150	188	300	2,30	1	
2433 1660 25	140	12,7	150	210	350	3,30	1	
2433 1760 25	160	14,6	150	240	380	4,70	1	
2433 1860 25	180	16,4	150	270	410	6,40	1	
2433 1960 25	200	18,2	150	300	430	8,30	1	
2433 2060 25	225	20,5	150	338	450	10,90	1	
2433 2160 25	250	22,7	250	375	570	17,10	1	
2433 2260 25	280	25,4	250	420	580	21,70	1	
2433 2360 25	315	28,6	300	496	690	32,80	1	
2433 2460 25	355	32,2	300	560	760	45,70	1	
2433 2560 25	400	36,3	300	637	780	59,40	1	
2433 2660 25	450	40,9	300	711	820	78,90	1	
2433 2760 25	500	45,4	300	783	960	114,20	1	
2433 2860 25	560	50,8	350	877	980	145,50	1	
2433 2960 25	630	57,2	350	955	1200	226,90	1	
2433 3060 25	710	64,5	350	1128	1450	348,80	1	
2433 3160 25	800	72,6	350	1274	1500	455,90	1	
2433 3260 25	900	81,7	400	1430	1650	634,20	1	

25.60.01.063 PE100 Rohrbogen 60° nahtlos lang **SDR17** schwarz  
PE100 Pipe bend 60° seamless long **SDR17** black

Teil / Item	D [mm]	e [mm]	L [mm]	r [mm]	z [mm]	KG	VE1	VE2
2434 1160 25	63	3,8	100	95	180	0,20	1	
2434 1260 25	75	4,5	100	113	220	0,40	1	
2434 1360 25	90	5,4	150	135	250	0,70	1	
2434 1460 25	110	6,6	150	165	280	1,10	1	
2434 1560 25	125	7,4	150	188	300	1,50	1	
2434 1660 25	140	8,3	150	210	350	2,20	1	
2434 1760 25	160	9,5	150	240	380	3,20	1	
2434 1860 25	180	10,7	150	270	410	4,30	1	
2434 1960 25	200	11,9	150	300	430	5,60	1	
2434 2060 25	225	13,4	150	338	450	7,40	1	
2434 2160 25	250	14,8	250	375	570	11,50	1	
2434 2260 25	280	16,6	250	420	580	14,70	1	
2434 2360 25	315	18,7	300	496	690	22,20	1	
2434 2460 25	355	21,1	300	560	760	31,00	1	
2434 2560 25	400	23,7	300	637	780	40,10	1	
2434 2660 25	450	26,7	300	711	820	53,30	1	
2434 2760 25	500	29,7	300	783	960	77,30	1	
2434 2860 25	560	33,2	350	877	980	98,40	1	
2434 2960 25	630	37,4	350	955	1200	153,30	1	
2434 3060 25	710	42,1	350	1128	1450	235,60	1	
2434 3160 25	800	47,4	350	1274	1500	307,90	1	
2434 3260 25	900	53,3	400	1430	1650	428,10	1	

## 2.04 Rohrbögen nahtlos • Pipe bends seamless

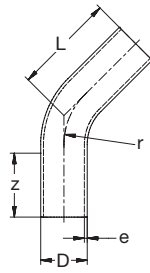

25.45.01.103 PE100 Rohrbogen 45° nahtlos lang **SDR11** schwarz  
PE100 Pipe bend 45° seamless long **SDR11** black

Teil / Item	D [mm]	e [mm]	L [mm]	r [mm]	z [mm]	KG	VE1	VE2
2433 1145 25	63	5,8	100	95	170	0,30	1	
2433 1245 25	75	6,9	100	113	180	0,40	1	
2433 1345 25	90	8,2	150	135	220	0,60	1	
2433 1445 25	110	10,0	150	165	240	1,00	1	
2433 1545 25	125	11,4	150	188	250	1,90	1	
2433 1645 25	140	12,7	150	210	270	2,60	1	
2433 1745 25	160	14,6	150	240	330	4,20	1	
2433 1845 25	180	16,4	150	270	350	5,60	1	
2433 1945 25	200	18,2	150	300	360	7,10	1	
2433 2045 25	225	20,5	150	338	380	9,40	1	
2433 2145 25	250	22,7	250	375	490	15,00	1	
2433 2245 25	280	25,4	250	420	510	19,50	1	
2433 2345 25	315	28,6	300	496	560	27,10	1	
2433 2445 25	355	32,2	300	560	630	38,70	1	
2433 2545 25	400	36,3	300	637	670	52,20	1	
2433 2645 25	450	40,9	300	711	750	74,10	1	
2433 2745 25	500	45,4	300	783	900	109,90	1	
2433 2845 25	560	50,8	350	877	950	145,20	1	
2433 2945 25	630	57,2	350	955	1000	193,50	1	
2433 3045 25	710	64,5	350	1128	1300	320,30	1	
2433 3145 25	800	72,6	350	1274	1400	437,10	1	
2433 3245 25	900	81,7	400	1430	1500	592,30	1	

25.45.01.063 PE100 Rohrbogen 45° nahtlos lang **SDR17** schwarz  
PE100 Pipe bend 45° seamless long **SDR17** black

Teil / Item	D [mm]	e [mm]	L [mm]	r [mm]	z [mm]	KG	VE1	VE2
2434 1145 25	63	3,8	100	95	170	0,20	1	
2434 1245 25	75	4,5	100	113	180	0,30	1	
2434 1345 25	90	5,4	150	135	220	0,60	1	
2434 1445 25	110	6,6	150	165	240	1,00	1	
2434 1545 25	125	7,4	150	188	250	1,30	1	
2434 1645 25	140	8,3	150	210	270	1,70	1	
2434 1745 25	160	9,5	150	240	330	2,80	1	
2434 1845 25	180	10,7	150	270	350	3,80	1	
2434 1945 25	200	11,9	150	300	360	4,80	1	
2434 2045 25	225	13,4	150	338	380	6,40	1	
2434 2145 25	250	14,8	250	375	490	10,10	1	
2434 2245 25	280	16,6	250	420	510	13,20	1	
2434 2345 25	315	18,7	300	496	560	18,40	1	
2434 2445 25	355	21,1	300	560	630	26,30	1	
2434 2645 25	450	26,7	300	711	750	50,10	1	
2434 2745 25	500	29,7	300	783	900	74,40	1	
2434 2845 25	560	33,2	350	877	950	98,20	1	
2434 2945 25	630	37,4	350	955	1000	130,90	1	
2434 3045 25	710	42,1	350	1128	1300	216,30	1	
2434 3145 25	800	47,4	350	1274	1400	285,30	1	
2434 3245 25	900	53,3	400	1430	1500	399,80	1	

## 2.04 Rohrbögen nahtlos • Pipe bends seamless

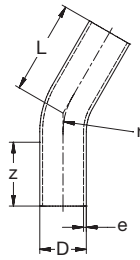

25.30.01.103 PE100 Rohrbogen 30° nahtlos lang **SDR11** schwarz  
PE100 Pipe bend 30° seamless long **SDR11** black

Teil / Item	D [mm]	e [mm]	L [mm]	r [mm]	z [mm]	KG	VE1	VE2
2433 1130 25	63	5,8	100	95	160	0,30	1	
2433 1230 25	75	6,9	100	113	170	0,50	1	
2433 1330 25	90	8,2	150	135	210	0,80	1	
2433 1430 25	110	10,0	150	165	220	1,30	1	
2433 1530 25	125	11,4	150	188	235	1,80	1	
2433 1630 25	140	12,7	150	210	250	2,40	1	
2433 1730 25	160	14,6	150	240	260	3,30	1	
2433 1830 25	180	16,4	150	270	280	4,50	1	
2433 1930 25	200	18,2	150	300	310	6,10	1	
2433 2030 25	225	20,5	150	338	350	8,80	1	
2433 2130 25	250	22,7	250	375	430	13,30	1	
2433 2230 25	280	25,4	250	420	450	17,40	1	
2433 2330 25	315	28,6	300	496	500	24,50	1	
2433 2430 25	355	32,2	300	560	590	36,80	1	
2433 2530 25	400	36,3	300	637	650	51,40	1	
2433 2630 25	450	40,9	300	711	700	70,20	1	
2433 2730 25	500	45,4	300	783	750	92,70	1	
2433 2830 25	560	50,8	350	877	800	123,90	1	
2433 2930 25	630	57,2	350	955	850	166,80	1	
2433 3030 25	710	64,5	350	1128	1150	287,00	1	
2433 3130 25	800	72,6	350	1274	1250	395,60	1	
2433 3230 25	900	81,7	400	1430	1350	540,70	1	

25.30.01.063 PE100 Rohrbogen 30° nahtlos lang **SDR17** schwarz  
PE100 Pipe bend 30° seamless long **SDR17** black

Teil / Item	D [mm]	e [mm]	L [mm]	r [mm]	z [mm]	KG	VE1	VE2
2434 1130 25	63	3,8	100	95	160	0,20	1	
2434 1230 25	75	4,5	100	113	170	0,30	1	
2434 1330 25	90	5,4	150	135	210	0,60	1	
2434 1430 25	110	6,6	150	165	220	0,90	1	
2434 1530 25	125	7,4	150	188	235	1,20	1	
2434 1630 25	140	8,3	150	210	250	1,60	1	
2434 1730 25	160	9,5	150	240	260	2,20	1	
2434 1830 25	180	10,7	150	270	280	3,00	1	
2434 1930 25	200	11,9	150	300	310	4,20	1	
2434 2030 25	225	13,4	150	338	350	5,90	1	
2434 2130 25	250	14,8	250	375	430	9,00	1	
2434 2230 25	280	16,6	250	420	450	11,80	1	
2434 2330 25	315	18,7	300	496	500	16,60	1	
2434 2430 25	355	21,1	300	560	590	24,90	1	
2434 2530 25	400	23,7	300	637	650	34,70	1	
2434 2630 25	450	26,7	300	711	700	47,40	1	
2434 2730 25	500	29,7	300	783	750	62,80	1	
2434 2830 25	560	33,2	350	877	800	83,80	1	
2434 2930 25	630	37,4	350	955	850	112,80	1	
2434 3030 25	710	42,1	350	1128	1150	193,80	1	
2434 3130 25	800	47,4	350	1274	1250	267,20	1	
2434 3230 25	900	53,3	400	1430	1350	365,00	1	

## 2.04 Rohrbögen nahtlos • Pipe bends seamless

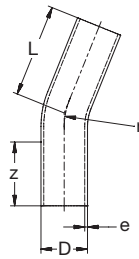

25.22.01.103 PE100 Rohrbogen **22°** nahtlos lang **SDR11** schwarz  
PE100 Pipe bend **22°** seamless long **SDR11** black

Teil / Item	D [mm]	e [mm]	L [mm]	r [mm]	z [mm]	KG	VE1	VE2
2433 1122 25	63	5,8	100	95	160	0,30	1	
2433 1222 25	75	6,9	100	113	170	0,50	1	
2433 1322 25	90	8,2	150	135	210	0,80	1	
2433 1422 25	110	10,0	150	165	220	1,30	1	
2433 1522 25	125	11,4	150	188	235	1,80	1	
2433 1622 25	140	12,7	150	210	250	2,40	1	
2433 1722 25	160	14,6	150	240	260	3,30	1	
2433 1822 25	180	16,4	150	270	280	4,50	1	
2433 1922 25	200	18,2	150	300	310	6,20	1	
2433 2022 25	225	20,5	150	338	350	8,80	1	
2433 2122 25	250	22,7	250	375	430	13,40	1	
2433 2222 25	280	25,4	250	420	450	17,50	1	
2433 2322 25	315	28,6	300	496	500	24,60	1	
2433 2422 25	355	32,2	300	560	590	36,90	1	
2433 2522 25	400	36,3	300	637	650	51,60	1	
2433 2622 25	450	40,9	300	711	700	70,50	1	
2433 2722 25	500	45,4	350	783	750	93,10	1	
2433 2822 25	560	50,8	350	877	800	124,50	1	
2433 2922 25	630	57,2	350	955	850	167,50	1	
2433 3022 25	710	64,5	350	1128	1150	288,00	1	
2433 3122 25	800	72,6	350	1274	1250	397,10	1	
2433 3222 25	900	81,7	400	1430	1350	542,90	1	

25.22.01.063 PE100 Rohrbogen **22°** nahtlos lang **SDR17** schwarz  
PE100 Pipe bend **22°** seamless long **SDR17** black

Teil / Item	D [mm]	e [mm]	L [mm]	r [mm]	z [mm]	KG	VE1	VE2
2434 1122 25	63	3,8	100	95	160	0,20	1	
2434 1222 25	75	4,5	100	113	170	0,30	1	
2434 1322 25	90	5,4	150	135	210	0,60	1	
2434 1422 25	110	6,6	150	165	220	0,90	1	
2434 1522 25	125	7,4	150	188	235	1,20	1	
2434 1622 25	140	8,3	150	210	250	1,60	1	
2434 1722 25	160	9,5	150	240	260	2,20	1	
2434 1822 25	180	10,7	150	270	280	3,10	1	
2434 1922 25	200	11,9	150	300	310	4,20	1	
2434 2022 25	225	13,4	150	338	350	6,00	1	
2434 2122 25	250	14,8	250	375	430	9,00	1	
2434 2222 25	280	16,6	250	420	450	11,80	1	
2434 2322 25	315	18,7	300	496	500	16,70	1	
2434 2422 25	355	21,1	300	560	590	25,00	1	
2434 2522 25	400	23,7	300	637	650	34,90	1	
2434 2622 25	450	26,7	300	711	700	47,60	1	
2434 2722 25	500	29,7	300	783	750	63,00	1	
2434 2822 25	560	33,2	350	877	800	84,10	1	
2434 2922 25	630	37,4	350	955	850	113,30	1	
2434 2222 25	710	42,1	350	1128	1150	194,50	1	
2434 3122 25	800	47,4	350	1274	1250	268,20	1	
2434 3222 25	900	53,3	400	1430	1350	366,40	1	

## 2.04 Rohrbögen nahtlos • Pipe bends seamless

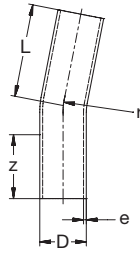

25.11.01.103 PE100 Rohrbogen 11° nahtlos lang **SDR11** schwarz  
PE100 Pipe bend 11° seamless long **SDR11** black

Teil / Item	D [mm]	e [mm]	L [mm]	r [mm]	z [mm]	KG	VE1	VE2
2433 1111 25	63	5,8	100	95	160	0,30	1	
2433 1211 25	75	6,9	100	113	170	0,50	1	
2433 1311 25	90	8,2	150	135	210	0,80	1	
2433 1411 25	110	10,0	150	165	220	1,30	1	
2433 1511 25	125	11,4	150	188	235	1,80	1	
2433 1611 25	140	12,7	150	210	250	2,40	1	
2433 1711 25	160	14,6	150	240	260	3,30	1	
2433 1811 25	180	16,4	150	270	280	4,50	1	
2433 1911 25	200	18,2	150	300	310	6,20	1	
2433 2011 25	225	20,5	150	338	350	8,80	1	
2433 2111 25	250	22,7	250	375	430	13,40	1	
2433 2211 25	280	25,4	250	420	450	17,50	1	
2433 2311 25	315	28,6	300	496	500	24,70	1	
2433 2411 25	355	32,2	300	560	590	37,00	1	
2433 2511 25	400	36,3	300	637	650	51,70	1	
2433 2611 25	450	40,9	300	711	700	70,60	1	
2433 2711 25	500	45,4	300	783	750	93,30	1	
2433 2811 25	560	50,8	350	877	800	124,70	1	
2433 2911 25	630	57,2	350	955	850	167,90	1	
2433 3011 25	710	64,5	350	1128	1150	288,60	1	
2433 3111 25	800	72,6	350	1274	1250	397,90	1	
2433 3211 25	900	81,7	400	1430	1350	544,10	1	

25.11.01.063 PE100 Rohrbogen 11° nahtlos lang **SDR17** schwarz  
PE100 Pipe bend 11° seamless long **SDR17** black

Teil / Item	D [mm]	e [mm]	L [mm]	r [mm]	z [mm]	KG	VE1	VE2
2434 1111 25	63	3,8	100	95	160	0,20	1	
2434 1211 25	75	4,5	100	113	170	0,30	1	
2434 1311 25	90	5,4	150	135	210	0,60	1	
2434 1411 25	110	6,6	150	165	220	0,90	1	
2434 1511 25	125	7,4	150	188	235	1,20	1	
2434 1611 25	140	8,3	150	210	250	1,60	1	
2434 1711 25	160	9,5	150	240	260	2,20	1	
2434 1811 25	180	10,7	150	270	280	3,10	1	
2434 1911 25	200	11,9	150	300	310	4,20	1	
2434 2011 25	225	13,4	150	338	350	6,00	1	
2434 2111 25	250	14,8	250	375	430	9,00	1	
2434 2211 25	280	16,6	250	420	450	11,90	1	
2434 2311 25	315	18,7	300	496	500	16,70	1	
2434 2411 25	355	21,1	300	560	590	25,10	1	
2434 2511 25	400	23,7	300	637	650	34,90	1	
2434 2611 25	450	26,7	300	711	700	47,70	1	
2434 2711 25	500	29,7	300	783	750	63,20	1	
2434 2811 25	560	33,2	350	877	800	84,30	1	
2434 2911 25	630	37,4	350	955	850	113,60	1	
2434 1111 25	710	42,1	350	1128	1150	194,90	1	
2434 3111 25	800	47,4	350	1274	1250	268,80	1	
2434 3211 25	900	53,3	400	1430	1350	367,30	1	



Der Werkstoff PP-R weist gegenüber PE eine erhöhte Steifigkeit, insbesondere im oberen Temperaturbereich, aus. Charakteristisch sind die hohe chemische Beständigkeit und die guten Langzeiteigenschaften gegenüber vielen Medien.

### Eigenschaften

- Hohe chemische Beständigkeit
- Korrosionsbeständigkeit
- Hervorragende Verarbeitbarkeit

### Werkstoff

PP-R (Polypropylen-Random-Copolymerisat) mit hohem Molekulargewicht und hoch wärme-stabilisiert, RAL 6017 Maigrün.

### Verbindungstechnik

- Heizelement-Muffen-Schweißung
- Heizwendel-Muffen-Schweißung
- Flanschverbindung



Compared to PE, PP-R has higher rigidity, particularly in the upper temperature range. The high resistance to chemicals and good long-term properties compared to many other media are characteristic.

### Properties

- Good resistance to chemicals
- Corrosion resistance
- Excellent processing capability

### Material

PP-R (Polypropylene-Random-Copolymerisate) with high molecular weight and high-heat stabilised, RAL 6017 May green.

### Joining technology

- Socket-welding
- Electrofusion socket-welding
- Flange connection



**3.01 Rohre einlagig**  
**Pipes single-layer** **PPR 4**

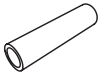

**3.02 Formteile Muffen-Schweißen**  
**Fittings socket-welding**

**3.02.01 Bögen + Winkel**  
**Elbows + Bends** **PPR 6**

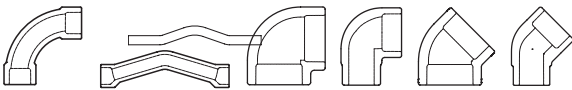

**3.02.02 T-Stücke + Abzweige**  
**Tee's + Branches** **PPR 8**

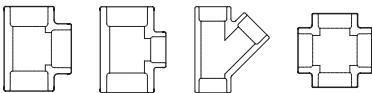

**3.02.03 Reduktionen, Muffen, Kappen**  
**Reducers, Sockets, Caps** **PPR 9**

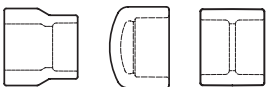

**3.02.04 Übergänge • Transitions** **PPR 10**

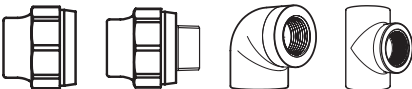

**3.02.05 Übergänge Wand**  
**Transitions wall** **PPR 12**



**3.02.06 Verschraubungen • Unions** **PPR 14**

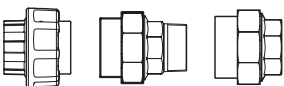

**3.02.07 Flanschverbindung**  
**Flange connection** **PPR 17**

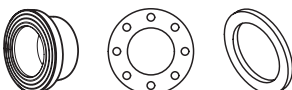

**3.02.08 Verteiler • Manifolds** **PPR 18**



**3.02.09 Kugelhähne • Ball valves** **PPR 19**

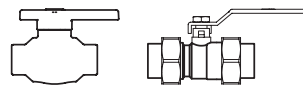

**3.02.10 Ventile • Valves** **PPR 20**



#### G 8200

##### Beschreibung

PP-R Druckrohr G 8200, einschichtig, SDR6.  
Homogenes Rohr für hohe Drücke in Heiß- und Kaltwassersystemen.

##### Werkstoff

PP-R (Polypropylen Random-Copolymer), Borealis RA130E, Farbe RAL 6017 Maigrün.  
Das Material entspricht den Anforderungen der aktuellen KTW-Leitlinie des Umweltbundesamtes (UBA).

##### Geometrische Eigenschaften

Außendurchmesser und Wanddicke entsprechend DIN 8077 und DIN EN ISO 15874.

##### Betriebsdruck

20°C / 2,0 MPa • 70°C / 1,0 MPa.

##### Ausführung

Geeignet für Heizelement-Muffen-Schweißung, Heizelement-Stumpf-Schweißung und Heizwendel-Muffen-Schweißung nach DVS Richtlinie 2207. Schweiß-Geräte und Schweiß-Werkzeuge sollten der DVS Richtlinie 2208 entsprechen.

##### Zertifizierung

B-R Rohre unterliegen regelmäßigen internen und externen Qualitätskontrollen. Die Rohre erfüllen die Anforderungen von AENOR, Bulgarcontrola, DVGW, Lloyds, ÖVGW und Watermark.

##### Lieferung

In 4 oder 5,8 m Stangen; abgepackt in Bündeln. Alle Bunde sind in schwarzer UV-Schutz-Schlauchfolie verpackt. Abgabe erfolgt nur in kompletten Verpackungseinheiten (VE's).

##### Description

PP-R Pressure pipe G 8200, single-layer, SDR6.  
Homogeneous pipe for high pressures in hot and cold water systems.

##### Material

PP-R (Polypropylene Random-Copolymer), Borealis RA130E, colour RAL 6017 May green.  
The material complies with the requirements of the KTW guideline of the German Federal Environmental Agency (UBA).

##### Geometric Properties

Outside diameter and wall thickness according to DIN 8077 and DIN EN ISO 15874.

##### Operating Pressure

20°C / 2,0 MPa • 70°C / 1,0 MPa.

##### Type

Useable for socket-welding, butt-welding and electrofusion-socket-welding according to DVS technical code 2207. Welding equipment according to DVS technical code 2208.

##### Certification

B-R pipes succumb frequent internal and external quality controls. The pipes fulfill the requirements of AENOR, Bulgarcontrola, DVGW, Lloyds, ÖVGW and Watermark.

##### Delivery

In 4 or 5,8 m rods; packed in bundles. All bundles are packed in black UV-protecton-foil. Supply only in complete packing units (VE's).

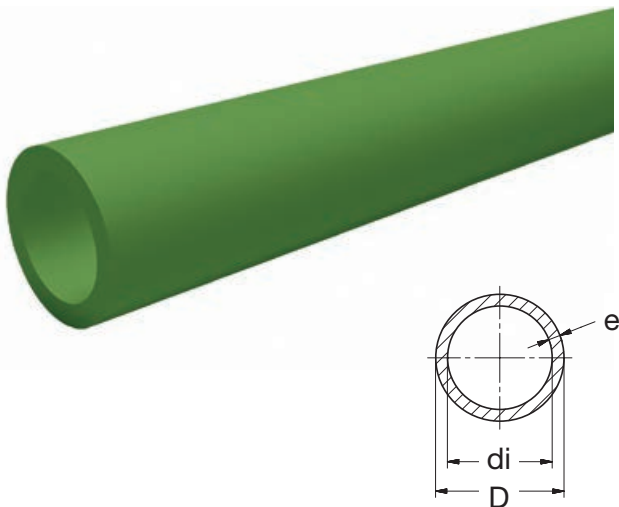

G 8200 PP-R Druckrohr **G 8200 SDR6** 2,0MPa grün  
PP-R Pressure-Pipe **G 8200 SDR6** 2,0MPa green

Teil / Item	D [mm]	e [mm]	DN [mm]	di [mm]	SDR	L [m]	kg [m]	VE1 [m]	VE2 [m]
5111 0540 11	16	2,7	10	10,6	6	4	0,11	100	-
5111 0640 11	20	3,4	12	13,2	6	4	0,18	100	-
5111 0740 11	25	4,2	14	16,6	6	4	0,28	100	-
5111 0840 11	32	5,4	20	21,2	6	4	0,46	60	-
5111 0940 11	40	6,7	25	26,6	6	4	0,68	40	-
5111 1040 11	50	8,3	32	33,2	6	4	1,09	20	-
5111 1140 11	63	10,5	40	42,0	6	4	1,40	20	-
5111 0658 11	20	3,4	12	13,2	6	5,8	0,18	145	-
5111 0758 11	25	4,2	14	16,6	6	5,8	0,28	145	-
5111 0858 11	32	5,4	20	21,2	6	5,8	0,46	87	-
5111 0958 11	40	6,7	25	26,6	6	5,8	0,68	58	-
5111 1058 11	50	8,3	32	33,2	6	5,8	1,09	29	-
5111 1158 11	63	10,5	40	42,0	6	5,8	1,40	29	-

#### G 8100R

##### Beschreibung

PP-R Druckrohr G 8100R, einschichtig, SDR11.  
Homogenes Rohr für Heiß- und Kaltwassersysteme.

##### Werkstoff

PP-R (Polypropylen Random-Copolymer), Borealis RA130E, Farbe RAL 6017 Maigrün.

Das Material entspricht den Anforderungen der aktuellen KTW-Leitlinie des Umweltbundesamtes (UBA).

##### Geometrische Eigenschaften

Außendurchmesser und Wanddicke entsprechend DIN 8077 und DIN EN ISO 15874.

##### Betriebsdruck

20°C / 1,5 MPa • 60°C / 0,8 MPa.

##### Ausführung

Geeignet für Heizelement-Muffen-Schweißung, Heizelement-Stumpf-Schweißung und Heizwendel-Muffen-Schweißung nach DVS Richtlinie 2207. Schweiß-Geräte und Schweiß-Werkzeuge sollten der DVS Richtlinie 2208 entsprechen.

##### Zertifizierung

B-R Rohre unterliegen regelmäßigen internen Qualitätskontrollen.

##### Lieferung

In 100 m Ringen. Alle Ringe sind in schwarzer UV-Schutzfolie verpackt. Abgabe erfolgt nur in kompletten Verpackungseinheiten (VE's).

##### Description

PP-R Pressure pipe G 8100R, single-layer, SDR11.  
Homogeneous pipe for hot and cold water systems.

##### Material

PP-R (Polypropylene Random-Copolymer), Borealis RA130E, colour RAL 6017 May green.

The material complies with the requirements of the KTW guideline of the German Federal Environmental Agency (UBA).

##### Geometric Properties

Outside diameter and wall thickness according to DIN 8077 and DIN EN ISO 15874.

##### Operating Pressure

20°C / 1,5 MPa • 60°C / 0,8 MPa.

##### Type

Suitable for socket-welding, butt-welding and electrofusion-socket-welding according to DVS technical code 2207. Welding equipment according to DVS technical code 2208.

##### Certification

B-R pipes succumb frequent internal quality controls.

##### Delivery

In 100 m coils; packed in bundles. All coils are packed in black UV-protection-foil. Supply only in complete packing units (VE's).

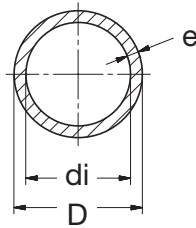

G 8100R PP-R Druckrohr **SDR11** 1,5MPa grün 100m-Ring  
PP-R Pressure-Pipe **SDR11** 1,5MPa green 100m-coil

Teil / Item	D [mm]	e [mm]	DN [mm]	di [mm]	SDR	L [m]	KG [m]	VE1 [m]	VE2 [m]
<b>20°C / 1,5MPa • 70°C / 0,5MPa</b>									
5114 06R1 11	20	2,0	15	16,0	11	100	0,11	100	-
5114 07R1 11	25	2,3	20	20,4	11	100	0,16	100	-

### 3.02 Formteile Muffen-Schweißen • Fittings socket-welding

#### Beschreibung

Gespritzte Formteile (ohne Verschwächungs-Beiwerte), für die Heizelement-Muffen-Schweißung.

#### Werkstoff

PP-R (Polypropylen Random-Copolymer), Borealis RA130E, Farbe RAL 6017 Maigrün.

Das Material entspricht den Anforderungen der aktuellen KTW-Leitlinie des Umweltbundesamtes (UBA).

#### Geometrische Eigenschaften

Durchmesser und Wanddicke der Muffen entsprechend DIN EN ISO 15874.

Toleranzen bei den Z-Maßangaben sind abhängig von der Dimension. Bis d/D 160 = +/- 3 mm.

#### Betriebsdruck

Der Betriebsdruck richtet sich üblicherweise nach dem eingesetzten Rohr. Grundsätzlich sind alle Standard-Formteile für die angebotenen Rohre geeignet.

#### Ausführung

Geeignet für Heizelement-Muffen-Schweißung nach DVS Richtlinie 2207.

Schweiß-Geräte und Schweiß-Werkzeuge sollten der DVS Richtlinie 2208 entsprechen.

#### Zertifizierung

B-R Formteile unterliegen laufenden internen und externen Qualitätskontrollen. Die Formteile erfüllen die Anforderungen von AENOR, Bulgarcontrola, DVGW, Lloyds, ÖVGW und Watermark.

#### Lieferung

Abgabe erfolgt nur in kompletten Verpackungseinheiten (VE's).

#### Description

Injection moulded fittings (without pressure reduction factors), for socket-welding.

#### Material

PP-R (Polypropylene Random-Copolymer), Borealis RA130E, colour RAL 6017 May green.

The material complies with the requirements of the KTW guideline of the German Federal Environmental Agency (UBA).

#### Geometric Properties

Diameter and wall thickness of the sockets according to DIN EN ISO 15874.

Tolerances of z-sizes depend on the dimension. Up to d/D 160 = +/- 3 mm.

#### Operating pressure

The operating pressure usually depends on the used pipe. Basically, all standard fittings are suitable for the offered pipes.

#### Type

Suitable for socket-welding according to DVS technical code 2207. Welding equipment according to DVS technical code 2208.

#### Certification

B-R fittings succumb internal and external quality controls. The fittings fulfill the requirements of AENOR, Bulgarcontrola, DVGW, Lloyds, ÖVGW and Watermark.

#### Delivery

Supply only in complete packing units (VE's).

### 3.02.01 Bögen + Winkel • Bends + Elbows

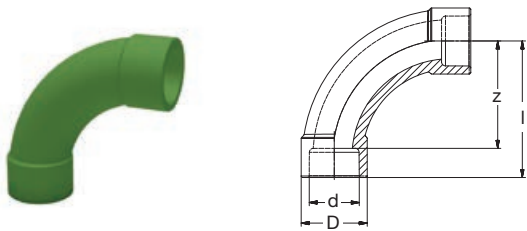

G 8002a PP-R Bogen 90° grün  
PP-R Bend 90° green

Teil / Item	d [mm]	D [mm]	l [mm]	z [mm]	KG	VE1	VE2
5421 0590 11	16	23	36	33	0,015	10	80
5421 0690 11	20	28	56	42	0,029	10	60
5421 0790 11	25	34	69	53	0,051	10	40
5421 0890 11	32	42	86	68	0,086	5	40
5421 0990 11	40	52	106	86	0,16	5	30

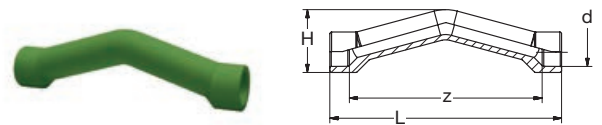

G 8287 PP-R Überspringbogen Muffe grün  
PP-R Crossover socket green

Teil / Item	d [mm]	H [mm]	L [mm]	z [mm]	KG	VE1	VE2
5461 0600 11	20	45	160	131	0,040	1	60
5461 0700 11	25	55	200	168	0,068	1	30
5461 0800 11	32	70	240	204	0,13	1	40

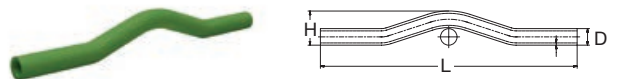

G 8285 PP-R Überspringbogen Rohr SDR7,4 grün  
PP-R Crossover pipe SDR7,4 green

Teil / Item	D [mm]	e [mm]	H [mm]	L [mm]	KG	VE1	VE2
5460 0500 11	16	2,7	≈ 38	≈ 365	0,03	1	
5460 0600 11	20	3,4	≈ 53	≈ 365	0,04	1	60
5460 0700 11	25	4,2	≈ 56	≈ 370	0,07	1	30
5460 0800 11	32	5,4	≈ 68	≈ 370	0,13	1	40

Nur für Kaltwasserleitungen • Only for cold water lines.

### 3.02.01 Bögen + Winkel • Bends + Elbows

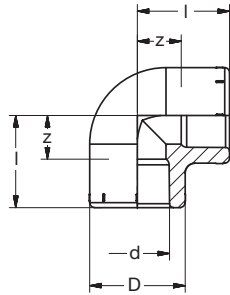

G 8090 PP-R Winkel 90° grün  
PP-R Elbow 90° green

Teil / Item	d [mm]	D [mm]	l [mm]	z [mm]	KG	VE1	VE2
5411 0590 11	16	26	24	11	0,016	10	150
5411 0690 11	20	29	28	13	0,019	10	120
5411 0790 11	25	34	32	16	0,025	10	80
5411 0890 11	32	43	38	20	0,047	10	80
5411 0990 11	40	52	44	23	0,073	5	50
5411 1090 11	50	65	52	28	0,14	10	60
5411 1190 11	63	84	62	34	0,27	4	32

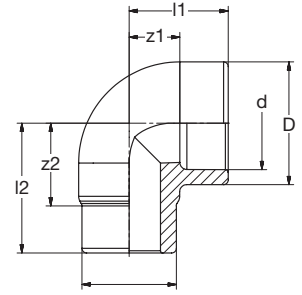

G 8092 PP-R Winkel 90° i-a grün  
PP-R Elbow 90° f-m green

Teil / Item	d [mm]	D [mm]	l1 [mm]	l2 [mm]	z1 [mm]	z2 [mm]	KG	VE1	VE2
5412 0590 21	16	24	22	25	9	12	0,015	10	120
5412 0690 11	20	29	27	36	12	21,5	0,018	10	140
5412 0790 11	25	34	30	41	14	25	0,026	10	80
5412 0890 11	32	43	36	48	18	30	0,048	10	50
5412 0990 11	40	52	42	55	21	34,5	0,075	5	30

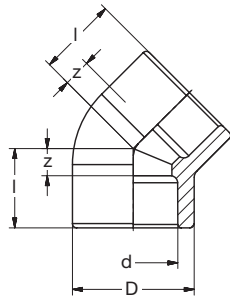

G 8041 PP-R Winkel 45° grün  
PP-R Elbow 45° green

Teil / Item	d [mm]	D [mm]	l [mm]	z [mm]	KG	VE1	VE2
5411 0545 11	16	23	19	6	0,008	10	150
5411 0645 11	20	29	21	6	0,014	10	150
5411 0745 11	25	34	24	8	0,019	10	90
5411 0845 11	32	43	28	10	0,034	10	50
5411 0945 11	40	52	32	11	0,056	5	30
5411 1045 11	50	65	37	13	0,10	5	45
5411 1145 11	63	82	44	16	0,21	2	40

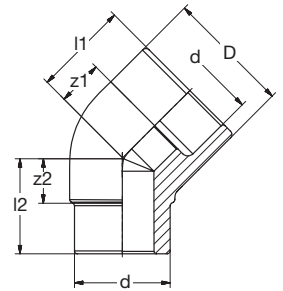

G 8040 PP-R Winkel 45° i-a grün  
PP-R Elbow 45° f-m green

Teil / Item	d [mm]	D [mm]	l1 [mm]	l2 [mm]	z1 [mm]	z2 [mm]	KG	VE1	VE2
5412 0645 11	20	29	20	28	5	14	0,013	10	120
5412 0745 11	25	34	22	34	5	18	0,023	10	80
5412 0845 11	32	43	26	39	8	21	0,041	5	50

### 3.02.02 T-Stücke + Abzweige • Tee's + Branches

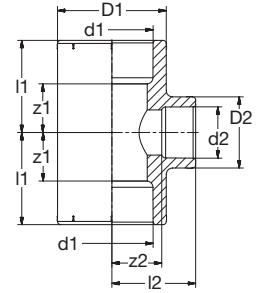
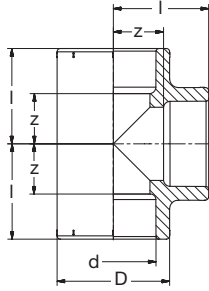

G 8130 PP-R T-Stück 90° grün  
PP-R Tee 90° green

Teil / Item	d [mm]	D [mm]	l [mm]	z [mm]	KG	VE1	VE2
5511 0590 11	16	23	24	11	0,014	10	80
5511 0690 11	20	29	28	13	0,023	10	80
5511 0790 11	25	34	32	16	0,034	10	50
5511 0890 11	32	43	38	20	0,060	5	70
5511 0990 11	40	52	44	23	0,090	5	40
5511 1090 11	50	65	52	28	0,17	10	50
5511 1190 11	63	84	62	34	0,34	2	8

G 8130 red PP-R T-Stück 90° red grün  
PP-R Tee 90° red green

Teil / Item	d1-d2 [mm]	D1 [mm]	D2 [mm]	l1 [mm]	l2 [mm]	z1 [mm]	z2 [mm]	KG	VE1	VE2
5521 0605 11	20-16	29	29	28	28	13	15	0,025	10	80
5521 0705 11	25-16	34	29	32	32	16	19	0,041	10	50
5521 0706 11	25-20	34	29	32	32	16	17	0,035	10	60
5521 0806 11	32-20	43	29	38	36	20	21	0,060	10	30
5521 0807 11	32-25	43	34	38	36	20	22	0,060	10	30
5521 0906 11	40-20	52	43	44	39	24	24	0,083	5	40
5521 0907 11	40-25	52	43	44	40	23	24	0,086	5	40
5521 0908 11	40-32	52	43	44	40	23	22	0,091	5	40
5521 1006 11	50-20	65	43	52	46	28	31	0,16	10	50
5521 1007 11	50-25	65	43	52	46	28	30	0,16	10	50
5521 1008 11	50-32	65	43	52	46	28	28	0,16	10	50
5521 1009 11	50-40	85	85	62	62	39	35	0,16	10	50
5521 1106 11	63-20	85	43	62	62	35	48	0,31	2	8
5521 1107 11	63-25	85	43	62	62	35	46	0,31	2	8
5521 1108 11	63-32	85	43	62	62	35	44	0,31	2	8
5521 1109 11	63-40	85	85	62	62	35	42	0,32	2	8
5521 1110 11	63-50	85	85	62	62	35	39	0,32	2	8
5521 0607 11	20-25	34	34	32	32	18	16	0,04	10	60

G 8130 red PP-R T-Stück 90° multi-red grün  
PP-R Tee 90° multi-red green

Teil / Item	d1-d2-d3 [mm]	D1 [mm]	D2 [mm]	l1 [mm]	l2 [mm]	z1 [mm]	z2 [mm]	KG	VE1	VE2
5521 07AA 11	25-20-20	34	34	32	32	16	18	0,038	10	60
5521 070A 11	25-25-20	34	34	32	32	16	16	0,038	10	60
5521 08BB 01	32-20-20	43	34	37	38	18	22	0,078	5	30
5521 08BA 21	32-20-25	43	34	37	38	18	23	0,078	5	30
5521 08AA 21	32-25-25	43	34	37	38	18	22	0,078	5	30
5521 11BA 11	63-40-50	85	85	62	62	39	35	0,37	2	8

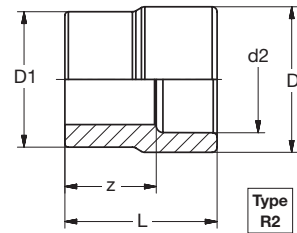
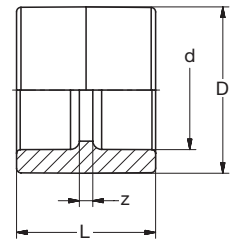
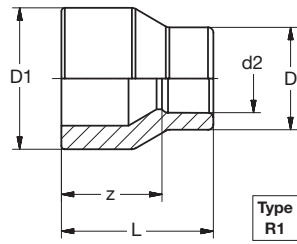

G 8270 PP-R Muffe grün  
PP-R Socket green

Teil / Item	d [mm]	D [mm]	L [mm]	z [mm]	KG	VE1	VE2
5311 0500 11	16	23	31	5	0,006	10	150
5311 0600 11	20	29	34	5	0,010	10	150
5311 0700 11	25	34	37	5	0,015	10	120
5311 0800 11	32	43	41	5	0,026	10	60
5311 0900 11	40	52	46	5	0,047	10	80
5311 1000 11	50	65	52	5	0,070	5	60
5311 1100 11	63	84	60	5	0,132	4	84

G 8243 PP-R Reduktion grün  
PP-R Reducer green

Teil / Item	D1 - d2 [mm]	Type R1 R2	D2 [mm]	L [mm]	z [mm]	KG	VE1	VE2
5321 0605 11	20-16	•	23	33	20	0,006	10	150
5321 0705 11	25-16	•	23	32	19	0,008	10	120
5321 0706 11	25-20	•	29	36	22	0,012	10	100
5321 0806 11	32-20	•	29	37	23	0,015	10	80
5321 0807 11	32-25	•	34	39	23	0,017	10	70
5321 0906 11	40-20	•	34	43	28	0,023	10	50
5321 0907 11	40-25	•	34	43	27	0,023	10	50
5321 0908 11	40-32	•	43	45	27	0,029	10	80
5321 1006 11	50-20	•	43	51	36	0,043	10	50
5321 1007 11	50-25	•	43	51	35	0,043	10	50
5321 1008 11	50-32	•	43	51	33	0,045	10	50
5321 1009 11	50-40	•	52	53	33	0,055	10	70
5321 1106 11	63-20	•	34	56	42	0,079	5	60
5321 1107 11	63-25	•	34	56	40	0,076	5	60
5321 1108 11	63-32	•	43	58	40	0,076	5	60
5321 1109 11	63-40	•	52	60	40	0,084	5	45
5321 1110 11	63-50	•	65	63	40	0,091	5	40

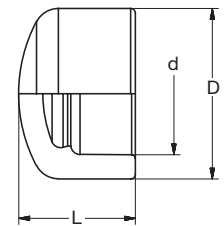

G 8301 PP-R Kappe grün  
PP-R Cap green

Teil / Item	d [mm]	D [mm]	L [mm]	KG	VE1	VE2
5341 0500 11	16	23	24	0,005	10	250
5341 0600 11	20	29	25	0,009	10	200
5341 0700 11	25	34	28	0,013	10	100
5341 0800 11	32	43	32	0,021	10	120
5341 0900 11	40	52	36	0,033	10	60
5341 1000 11	50	65	41	0,057	10	80
5341 1100 11	63	79	48	0,090	5	60

### 3.02.04 Übergänge • Transitions

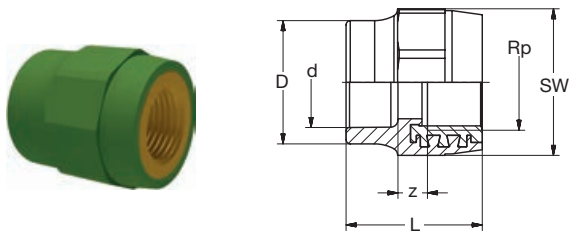

G 8270g PP-R-RG Übergang IG-zyl grün  
PP-R-Bronze Transition female-thread-cyl green

Teil / Item	d x Rp [mm x Inch]	D [mm]	L [mm]	z [mm]	SW [mm]	KG	VE1	VE2
5R11 0543 11	16 x 1/2	29	39	11	36	0,067	10	-
5R11 0643 11	20 x 1/2	30	40	11	36	0,068	10	-
5R11 0645 11	20 x 3/4	29	40	11	44	0,10	10	-
5R11 0743 11	25 x 1/2	34	41	11	36	0,068	10	-
5R11 0745 11	25 x 3/4	34	41	11	44	0,10	10	-
5R11 0845 11	32 x 3/4	43	45	11	44	0,11	10	-
5R11 0846 11	32 x 1	43	48	12	51	0,15	10	-
5R11 0946 11	40 x 1	55	54	14	63	0,20	10	-
5R11 0947 11	40 x 1 1/4	55	54	13	63	0,22	10	-
5R11 1047 11	50 x 1 1/4	64	58	12	70	0,24	10	-
5R11 1948 11	50 x 1 1/2	64	58	14	70	0,24	10	-
5R11 1150 11	63 x 2	79	69	19	85	0,49	5	-

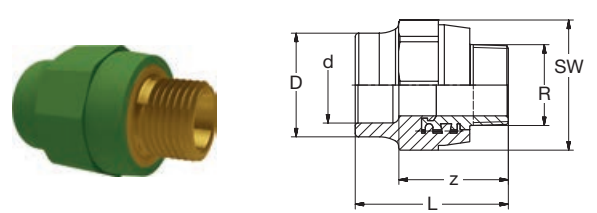

G 8243g PP-R-RG Übergang AG-keg grün  
PP-R-Bronze Transition male-thread-con green

Teil / Item	d x R [mm x Inch]	D [mm]	L [mm]	z [mm]	SW [mm]	KG	VE1	VE2
5R11 0573 11	16 x 1/2	24	53	40	36	0,086	10	-
5R11 0673 11	20 x 1/2	29	53	40	36	0,087	10	-
5R11 0675 11	20 x 3/4	34	58	42	44	0,12	10	-
5R11 0773 11	25 x 1/2	34	56	40	36	0,086	10	-
5R11 0775 11	25 x 3/4	34	58	42	44	0,12	10	-
5R11 0875 11	32 x 3/4	43	58	42	44	0,13	10	-
5R11 0876 11	32 x 1	43	66	48	51	0,19	10	-
5R11 0976 11	40 x 1	55	71	51	62	0,24	10	-
5R11 0977 11	40 x 1 1/4	52	74	53	63	0,31	10	-
5R11 1077 11	50 x 1 1/4	64	77	54	70	0,33	10	-
5R11 1078 11	50 x 1 1/2	64	77	54	70	0,35	10	-
5R11 1180 11	63 x 2	79	92	65	85	0,65	5	-

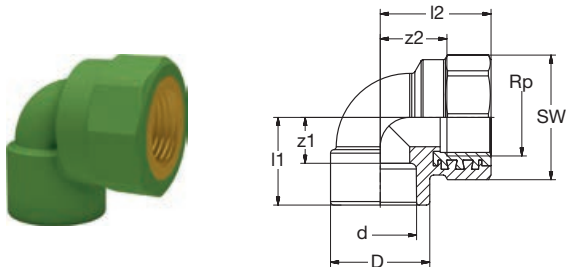

G 8090g PP-R-RG Ü-Winkel 90° IG-zyl grün  
PP-R-Bronze Transition-Elbow 90° female-thread-cyl green

Teil / Item	d x Rp [mm x Inch]	D [mm]	l1 [mm]	l2 [mm]	z1 [mm]	z2 [mm]	SW [mm]	KG	VE1	VE2
5R21 0543 11	16 x 1/2	23	25	32	12	18	36	0,074	10	-
5R21 0643 11	20 x 1/2	29	28	34	14	20	36	0,075	10	-
5R21 0645 11	20 x 3/4	34	32	40	18	25	44	0,12	10	-
5R21 0743 11	25 x 1/2	34	32	36	14	24	36	0,075	10	-
5R21 0745 11	25 x 3/4	34	32	40	16	25	44	0,12	10	-
5R21 0845 11	32 x 3/4	43	38	45	20	30	44	0,13	10	-
5R21 0846 11	32 x 1	43	38	48	20	30	51	0,18	10	-

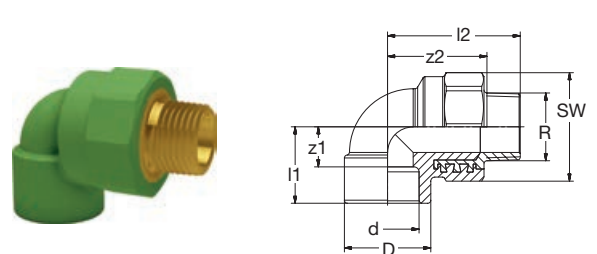

G 8092g PP-R-RG Ü-Winkel 90° AG-keg grün  
PP-R-Bronze Transition-Elbow 90° male-thread-con green

Teil / Item	d x R [mm x Inch]	D [mm]	l1 [mm]	l2 [mm]	z1 [mm]	z2 [mm]	SW [mm]	KG	VE1	VE2
5R21 0573 11	16 x 1/2	23	25	32	12	18	36	0,096	10	-
5R21 0673 11	20 x 1/2	29	28	34	14	20	36	0,093	10	-
5R21 0675 11	20 x 3/4	34	32	40	18	25	44	0,14	10	-
5R21 0773 11	25 x 1/2	34	32	36	16	24	36	0,096	10	-
5R21 0775 11	25 x 3/4	34	32	40	16	25	44	0,14	10	-
5R21 0875 11	32 x 3/4	43	38	45	20	30	44	0,15	10	-
5R21 0876 11	32 x 1	43	38	48	20	30	51	0,21	10	-

### 3.02.04 Übergänge • Transitions

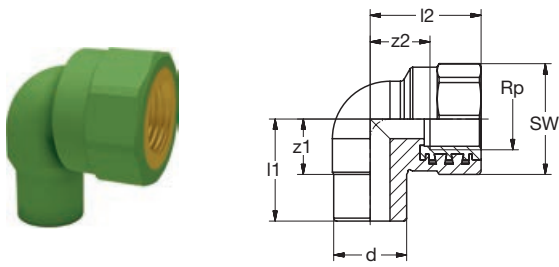

G 8091g PP-R-RG Ü-Winkel 90° i IG-zyl grün  
PP-R-Bronze Transition-Elbow 90° fem female-thread-cyl green

Teil / Item	d x Rp [mm x Inch]	l1 [mm]	l2 [mm]	z1 [mm]	z2 [mm]	SW [mm]	KG	VE1	VE2
5R22 0643 11	20 x 1/2	34	34	19	18	36	0,072	10	-

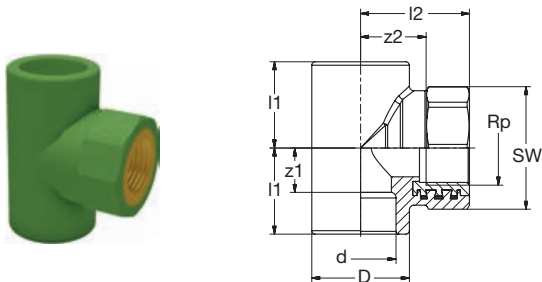

G 8130g PP-R-RG Ü-T-Stück 90° IG-zyl grün  
PP-R-Bronze Transition-Tee 90° female-thread-cyl green

Teil / Item	d x Rp [mm x Inch]	D [mm]	l1 [mm]	l2 [mm]	z1 [mm]	z2 [mm]	SW [mm]	KG	VE1	VE2
5R41 0543 11	16 x 1/2	23	25	32	12	18	36	0,080	10	-
5R41 0643 11	20 x 1/2	29	28	34	14	20	36	0,080	10	-
5R41 0645 11	20 x 3/4	34	28	35	14	20	44	0,13	10	-
5R41 0743 11	25 x 1/2	34	32	38	16	24	36	0,087	10	-
5R41 0745 11	25 x 3/4	34	32	40	16	25	44	0,13	10	-
5R41 0845 11	32 x 3/4	43	38	45	20	30	44	0,15	10	-
5R41 0846 11	32 x 1	43	38	48	20	30	51	0,2	10	-

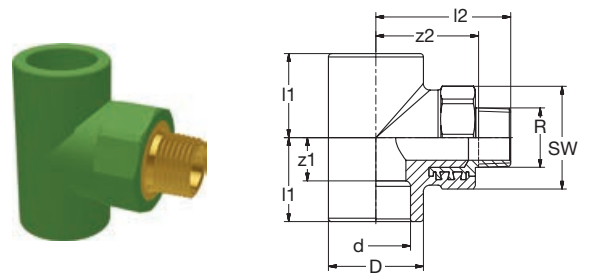

G 8133g PP-R-RG Ü-T-Stück 90° AG-keg grün  
PP-R-Bronze Transition-Tee 90° male-thread-con green

Teil / Item	d x R [mm x Inch]	D [mm]	l1 [mm]	l2 [mm]	z1 [mm]	z2 [mm]	SW [mm]	KG	VE1	VE2
5R41 0573 11	16 x 1/2	23	25	32	12	47	36	0,10	10	-
5R41 0673 11	20 x 1/2	29	28	34	14	49	36	0,10	10	-
5R41 0675 11	20 x 3/4	29	28	35	14	50	44	0,15	10	-
5R41 0773 11	25 x 1/2	34	32	38	16	53	36	0,11	10	-
5R41 0775 11	25 x 3/4	34	32	40	16	55	44	0,14	10	-
5R41 0875 11	32 x 3/4	43	38	45	20	60	44	0,17	10	-
5R41 0876 11	32 x 1	43	38	48	20	66	51	0,24	10	-

### 3.02.05 Übergänge Wand • Transitions wall

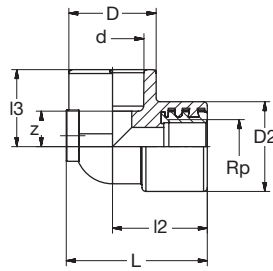
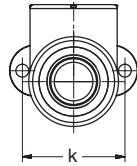

G 8472g PP-R-RG Ü-Winkel 90° Wandbefestigung IG-zyl grün  
PP-R-Bronze Transition-Elbow 90° wall mount female-thread-cyl green

Teil / Item	d x Rp [mm x Inch]	D [mm]	D2 [mm]	L [mm]	l2 [mm]	l3 [mm]	k [mm]	z [mm]	KG	VE1	VE2
5R31 0543 11	16 x 1/2	35	29	50	35	27	40	21	0,077	10	-
5R31 0643 11	20 x 1/2	35	29	50	35	27	40	21	0,077	10	-
5R31 0743 11	25 x 1/2	35	34	54	37	30	40	23	0,14	10	-
5R31 0745 11	25 x 3/4	43	43	65	43	35	50	28	0,14	10	-
5R31 0845 11	32 x 3/4	43	43	65	43	35	50	28	0,14	10	-

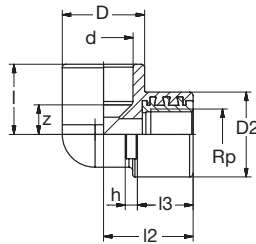
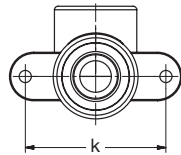

G 8473g PP-R-RG Ü-Winkel 90° Hohlwandbefestigung IG-zyl grün  
PP-R-Bronze Transition-Elbow 90° hollow wall mount female-thread-cyl green

Teil / Item	d x Rp [mm x Inch]	D [mm]	D2 [mm]	l [mm]	l2 [mm]	l3 [mm]	h [mm]	k [mm]	z [mm]	KG	VE1	VE2
5R3H 0543 11	16 x 1/2	29	35	27	34	21	5	14	14	0,070	10	-
5R3H 0643 11	20 x 1/2	29	35	27	34	21	5	13	13	0,077	10	-
5R3H 0743 11	25 x 1/2	34	35	30	37	23	5	14	14	0,083	10	-

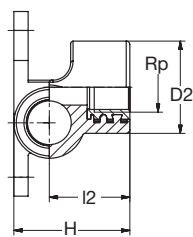
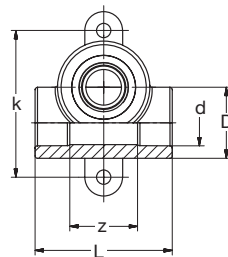

G 8490g PP-R-Ms Ü-Winkel 90° Durchgang Wandbefestigung IG-zyl grün  
PP-R-Brass Transition-Elbow 90° passage wall mount female-thread-cyl green

Teil / Item	d x Rp [mm x Inch]	D [mm]	D2 [mm]	L [mm]	l2 [mm]	H [mm]	k [mm]	z [mm]	KG	VE1	VE2
5M3D 0643 31	20 x 1/2	30	39	58	34	49	62	29	0,077	10	-

### 3.02.05 Übergänge Wand • Transitions wall

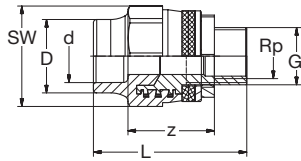

G 8244g PP-R-RG Übergang Hohlwandbefestigung IG-zyl grün  
 G 8245g PP-R-Bronze Transition hollow wall mount female-thread-cyl green

Teil / Item	d x Rp x G [mm x Inch]	D [mm]	L [mm]	z [mm]	SW [mm]	KG	VE1	VE2
<b>Länge • Length G = 30 mm</b>								
5R1L 0545 11	16 x 1/2 x 3/4	43	70	32	44	0,24	10	-
5R1L 0645 11	20 x 1/2 x 3/4	43	70	40,5	44	0,24	10	-
<b>Länge • Length G = 19 mm</b>								
5R1H 0545 11	16 x 1/2 x 3/4	43	59	31	44	0,21	10	-
5R1H 0645 11	20 x 1/2 x 3/4	43	59	29,5	44	0,21	10	-

Komplett mit Kontersatz • complete with counter set.

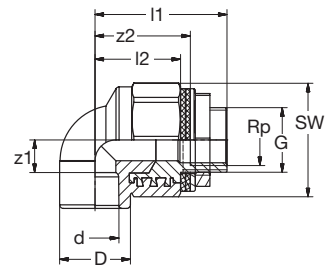

G 8093g PP-R-RG Ü-Winkel 90 Hohlwandbefestigung IG-zyl grün  
 G 8095g PP-R-Bronze Transition-Elbow 90 hollow wall mount male-thread-cyl green

Teil / Item	d x Rp x G [mm x Inch]	D [mm]	l1 [mm]	l2 [mm]	z1 [mm]	z2 [mm]	SW [mm]	KG	VE1	VE2
<b>Länge • Length G = 30 mm</b>										
5R2L 0545 11	16 x 1/2 x 3/4	29	65	35	15	50	44	0,25	10	-
5R2L 0645 11	20 x 1/2 x 3/4	29	65	35	13,5	50	44	0,25	10	-
<b>Länge • Length G = 19 mm</b>										
5R2H 0545 11	16 x 1/2 x 3/4	29	54	35	15	39	44	0,23	10	-
5R2H 0645 11	20 x 1/2 x 3/4	29	54	35	13,5	39	44	0,23	10	-

Komplett mit Kontersatz • complete with counter set.

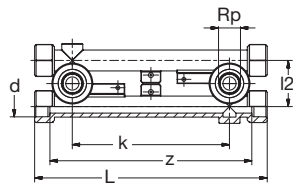

G 8492g PP-R-Ms Montagegruppe 1 - Durchgang grün  
 PP-R-Brass Mounting group 1 - passage green

Teil / Item	d x Rp [mm x Inch]	L [mm]	l2 [mm]	k* [mm]	z [mm]	KG	VE1	VE2
5M9D 0643 31	20 x 1/2	222	44	150	193	0,43	1	-
				137				
				113				
				100				

\* verstellbar • adjustable.

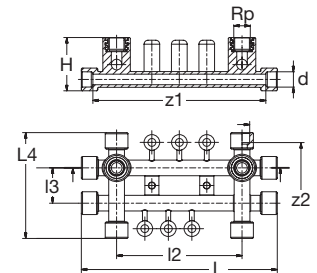

G 8494g PP-R-RG Montagegruppe 2 - Kreuz grün  
 PP-R-Bronze Mounting group 2 - Cross green

Teil / Item	d x Rp [mm x Inch]	L [mm]	l2 [mm]	l3 [mm]	L4 [mm]	H [mm]	z1 [mm]	z2 [mm]	KG	VE1	VE2
5R9K 0643 11	20 x 1/2	250	160	90	135	69	221	106	0,39	1	-

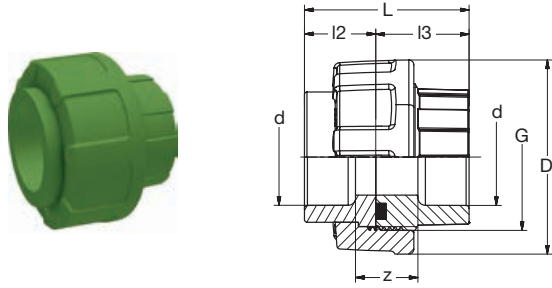

G 8330A PP-R Verschraubung Runddichtring-EPDM 20°C 10bar grün  
PP-R Union O-Ring-gasket-EPDM 20°C 10bar green

Teil / Item	d [mm]	D [mm]	G [Inch]	L [mm]	l2 [mm]	l3 [mm]	z [mm]	KG	VE1	VE2
5351 0600 31	20	46	1	44,0	17,5	26	15	0,039	1	150
5351 0700 31	25	56	1 1/4	47,5	19,0	28	15	0,061	1	125
5351 0800 31	32	66	1 1/2	51,5	21,0	30	15	0,091	1	100
5351 0900 31	40	79	2	58,0	23,5	34	17	0,14	1	60
5351 1000 31	50	87	2 1/4	66,0	26,5	39	19	0,17	1	40
5351 1100 31	63	107	2 3/4	78,5	30,5	47	23	0,28	1	30

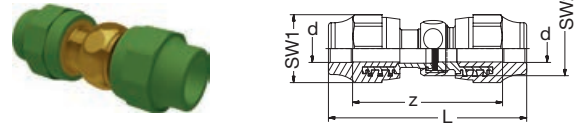

G 8330 PP-R-RG Verschraubung Flachdichtring-EPDM grün  
PP-R-Bronze Union flat-gasket-EPDM green

Teil / Item	d [mm]	L [mm]	z [mm]	SW1 [mm]	SW2 [mm]	KG	VE1	VE2
5R51 0500 11	16	111	82	36	30	0,24	1	50
5R51 0600 11	20	116	87	44	37	0,25	1	50
5R51 0700 11	25	119	87	44	37	0,39	1	30
5R51 0800 11	32	134	96	51	46	0,58	1	20
5R51 0900 11	40	152	110	63	52	0,98	1	12
5R51 1000 11	50	164	116	70	59	1,20	1	8
5R51 1100 11	63	189	134	85	74	2,10	1	6

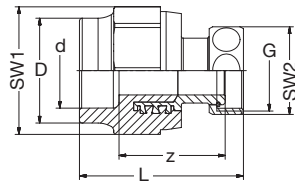

G 8332 PP-R-RG Anschlussverschraubung für Armaturen + Wasserzähler IG-zyl mit Flachdichtring-EPDM grün  
PP-R-Bronze Union flat-sealing for Valves + Water meters female-thread-cyl with flat-gasket-EPDM green

Teil / Item	d x G [mm x Inch]	D [mm]	L [mm]	z [mm]	SW1 [mm]	SW2 [mm]	KG	VE1	VE2
5R51 05A0 11	16 x 3/4	29	66	44	36	30	0,11	1	50
5R51 06A0 11	20 x 3/4	29	66	44	36	30	0,14	1	50
5R51 06A1 11	20 x 1	29	72	44	44	37	0,23	1	30
5R51 07A0 11	25 x 3/4	34	67	44	44	30	0,13	1	50
5R51 07A1 11	25 x 1	34	72	47	44	37	0,20	1	30
5R51 08A0 11	32 x 1	43	80	53	51	37	0,19	1	20
5R51 08A1 11	32 x 1 1/4	43	80	53	51	46	0,32	1	20
5R51 09A0 11	40 x 1 1/4	55	86	56	63	46	0,38	1	12
5R51 09A1 11	40 x 1 1/2	55	90	58	63	52	0,57	1	12
5R51 10A0 11	50 x 1 3/4	64	98	61	70	59	0,62	1	8
5R51 11A0 11	63 x 2 3/8	79	114	71	85	74	1,08	1	6

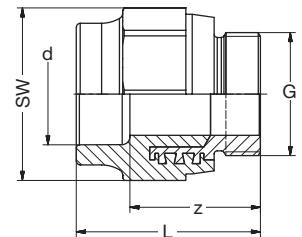

G 8333 PP-R-RG Verschraubung Schraubteil flachdichtend grün  
PP-R-Bronze Union Screw-part flat-sealing green

Teil / Item	d x G [mm x Inch]	L [mm]	z [mm]	SW [mm]	KG	VE1	VE2
5R51 05S0 11	16 x 3/4	50	37	36	0,099	1	50
5R51 06S0 11	20 x 3/4	50	34	36	0,11	1	50
5R51 06S1 11	20 x 1	53	38	44	0,14	1	30
5R51 07S0 11	25 x 3/4	51	35	36	0,11	1	50
5R51 07S1 11	25 x 1	54	38	44	0,14	1	30
5R51 08S1 11	32 x 1 1/4	62	43	51	0,45	1	20
5R51 09S1 11	40 x 1 1/2	72	51	63	0,75	1	12
5R51 10S0 11	50 x 1 3/4	77	53	70	1,50	1	8
5R51 11S0 11	63 x 2 3/8	88	60	85	2,33	1	6

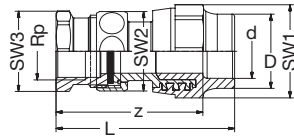

G 8332g PP-R-RG Ü-Verschraubung IG-zyl Flachdichtring-EPDM grün  
 PP-R-Bronze Transition-Union female-thread-cyl flat-gasket-EPDM green

Teil / Item	d x Rp [mm x Inch]	G [Inch]	D [mm]	L [mm]	z [mm]	SW1 [mm]	SW2 [mm]	SW3 [mm]	KG	VE1	VE2
5R51 0543 11	16 x 1/2	3/4	29	85	71	36	30	27	0,19	1	50
5R51 0643 11	20 x 1/2	3/4	29	85	70	36	30	27	0,19	1	50
5R51 0645 11	20 x 3/4	1	29	93	78	44	37	34	0,34	1	30
5R51 0743 11	25 x 1/2	3/4	34	87	71	36	30	27	0,19	1	50
5R51 0745 11	25 x 3/4	1	34	95	79	44	37	34	0,30	1	30
5R51 0845 11	32 x 3/4	1	43	97	79	44	37	34	0,34	1	20
5R51 0846 11	32 x 1	1 1/4	43	103	85	51	46	44	0,51	1	20
5R51 0947 11	40 x 1 1/4	1 1/2	52	115	94	63	52	50	0,66	1	12
5R51 1048 11	50 x 1 1/2	1 3/4	64	126	102	70	59	55	0,82	1	8
5R51 1150 11	63 x 2	2 3/8	79	142	114	85	74	70	1,30	1	3

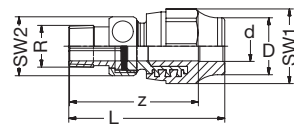

G 8333g PP-R-RG Ü-Verschraubung AG-keg Flachdichtring-EPDM grün  
 PP-R-Bronze Transition-Union male-thread-con flat-gasket-EPDM green

Teil / Item	d x Rp [mm x Inch]	G [Inch]	D [mm]	L [mm]	z [mm]	SW1 [mm]	SW2 [mm]	KG	VE1	VE2
5R51 0573 11	16 x 1/2	3/4	29	79	66	36	30	0,17	1	50
5R51 0673 11	20 x 1/2	3/4	29	79	65	36	30	0,18	1	50
5R51 0675 11	20 x 3/4	1	29	86	72	44	37	0,28	1	30
5R51 0773 11	25 x 1/2	3/4	34	81	65	36	30	0,16	1	50
5R51 0775 11	25 x 3/4	1	34	88	72	44	37	0,27	1	30
5R51 0875 11	32 x 3/4	1	43	81	63	44	37	0,29	1	20
5R51 0876 11	32 x 1	1 1/4	43	98	80	51	46	0,42	1	20
5R51 0977 11	40 x 1 1/4	1 1/2	52	113	92	63	52	0,56	1	12
5R51 1078 11	50 x 1 1/2	1 3/4	64	119	96	70	59	0,75	1	8
5R51 1180 11	63 x 2	2 3/8	79	137	109	85	74	1,27	1	3

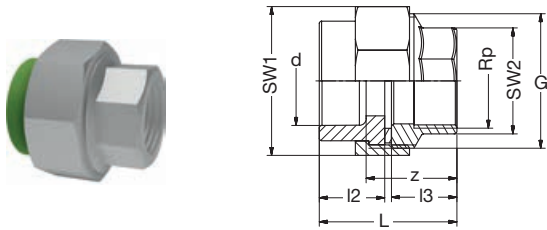

G 8542g PP-R-V2A Ü-Verschraubung IG-zyl Flachdichtring-EPDM 20°C/1.0MPa grün  
 PP-R-Stainless steel Transition-Union female-thread-cyl flat-gasket-EPDM 20°C/1.0MPa green

Teil / Item	d x Rp [mm x Inch]	DN [mm]	G [Inch]	L [mm]	l2 [mm]	l3 [mm]	z [mm]	SW1 [mm]	SW2 [mm]	KG	VE1	VE2
5V51 0643 11	20 x 1/2	15	1	49	21	25	34	38	27	0,13	1	
5V51 0745 11	25 x 3/4	20	1 1/4	52	21	28	36	47	32	0,22	1	
5V51 0846 11	32 x 1	25	1 1/2	57	23	31	39	52	38	0,28	1	
5V51 0947 11	40 x 1 1/4	32	2	62	26	33	41	66	47	0,46	1	
5V51 1048 11	50 x 1 1/2	40	2 1/4	68	29	36	44	72	53	0,56	1	
5V51 1150 11	63 x 2	50	2 3/4	78	33	42	50	87	65	0,93	1	

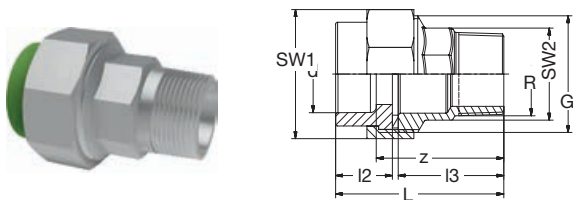

G 8547g PP-R-V2A Ü-Verschraubung AG-keg Flachdichtring-EPDM 20°C/1.0MPa grün  
 PP-R-Stainless steel Transition-Union male-thread-con flat-gasket-EPDM 20°C/1.0MPa green

Teil / Item	d x R [mm x Inch]	DN [mm]	G [Inch]	L [mm]	l2 [mm]	l3 [mm]	z [mm]	SW1 [mm]	SW2 [mm]	KG	VE1	VE2
5V51 0673 11	20 x 1/2	15	1	68	21	43	52	38	27	0,16	1	
5V51 0775 11	25 x 3/4	20	1 1/4	73	21	49	58	47	27	0,26	1	
5V51 0876 11	32 x 1	25	1 1/2	79	23	53	61	52	34	0,35	1	
5V51 0977 11	40 x 1 1/4	32	2	87	26	58	82	66	43	0,56	1	
5V51 1078 11	50 x 1 1/2	40	2 1/4	94	29	62	89	72	50	0,71	1	
5V51 1180 11	63 x 2	50	2 3/4	107	33	71	102	87	61	1,06	1	

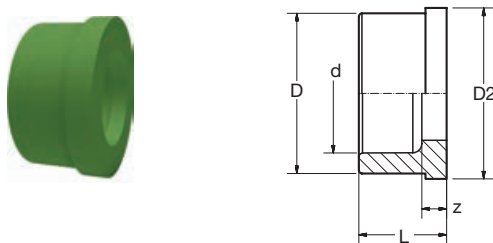

G 8060 PP-R Verschraubung Einlegeteil grün  
 PP-R Union Insert-part green

Teil / Item	d [mm]	D [mm]	D2 [mm]	L [mm]	z [mm]	KG	VE1	VE2
5351 06E0 11	20	27,5	30,0	21	6	0,006	1	-
5351 07E0 11	25	36	38,5	21	6	0,012	1	-
5351 08E0 11	32	41,5	44,7	23	6	0,014	1	-
5351 09E0 11	40	53	56,5	28	7	0,029	1	-
5351 10E0 11	50	59	62,6	32	8	0,036	1	-
5351 11E0 11	63	74	78,5	42	13	0,063	1	-

#### Flanschadapter Muffe (Bundbuchse) in gerillter Ausführung für den Einsatz von Flachdichtungen.

Weitere Informationen zu Flanschen und Dichtungen finden Sie unter 6. Zubehör.

#### Flange adaptor socket grooved for the use of flat gaskets.

More information about flanges and gaskets see 6. Accessories.

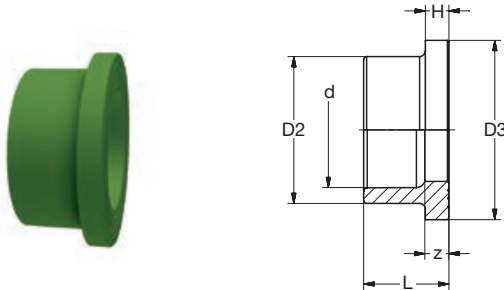
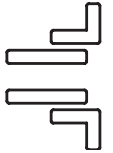

G 8790 PP-R Bundbuchse gerillt grün  
PP-R Flange adaptor socket grooved green

Teil / Item	d [mm]	D2 [mm]	D3 [Zoll]	L [mm]	H [mm]	z [mm]	KG	VE1	VE2
5331 09F0 11	40	61	50	29	8	9	0,027	2	-
5331 10F0 11	50	74	61	27	8	4	0,043	2	-
5331 11F0 11	63	102	76	40	17	13	0,11	2	-

#### Zubehör Flanschverbindung B-Buchse PP-R Accessories Flange Connection socket PP-R



Losflansch  
Flange loose



Blindflansch  
Flange blind



Flachdichtung mit Stahl-Einlage  
Flat gasket with steel-inlay

d [mm]	DN [mm]	PP-St		PP-GGG	PP-St
		DIN/EN	ANSI		
		PN10/16	150 lbs		
40	32	9141 09E1 15	9141 09A2 38		
50	40	9141 10E1 15	9141 10A2 38		
63	50	9141 11E1 15	9151 11A2 25		

PP-St	
DIN/EN	ANSI
PN10/16	150 lbs
9144 09E1 35	9144 09A2 38
9144 10E1 35	9144 10A2 38
9144 11E1 35	9144 11A2 38

EPDM-St	NBR-St
Wasser/Water	Gas/Gas
PN10	
9202 09F1 35	9202 09F2 35
9202 10F1 35	9202 10F2 35
9202 11F1 35	9202 11F2 35

### 3.02.08 Verteiler • Manifolds

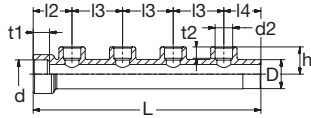

G 8240 PP-R Verteiler Muffe kaskadierbar grün  
PP-R Manifold socket cascadable green

Teil / Item	d/D - d2 x n [mm]	L [mm]	l2 [mm]	l3 [mm]	l4 [mm]	t1 [mm]	t2 [mm]	h [mm]	KG	VE1	VE2
5584 0705 11	25 - 16 x 4	234	37	56	32	16	13	26	0,080	1	30
5584 0806 11	32 - 20 x 4	245	43	56	37	18	14,5	30	0,13	1	20
5584 0807 11	32 - 25 x 4	250	43	56	41	18	16	35	0,15	1	30
5584 0907 11	40 - 25 x 4	248	43	56	41	20,5	16	38	0,21	1	20

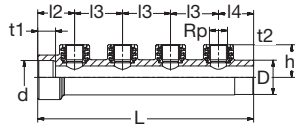

G 8240g PP-R-RG Verteiler IG-zyl kaskadierbar grün  
PP-R-Bronze Manifold female-thread-cyl cascadable green

Teil / Item	d/D x Rp x n [mm x Inch]	L [mm]	l2 [mm]	l3 [mm]	l4 [mm]	t1 [mm]	t2 [mm]	h [mm]	KG	VE1	VE2
5R84 0843 11	32 x 1/2 x 4	250	43	56	41	18	14	35	0,35	1	40
5R84 0943 11	40 x 1/2 x 4	250	43	56	41	20,5	14	38	0,40	1	25
5R82 1144 11	63 x 3/4 x 2	434	148	204	82	27,5	15	59	0,74	1	15

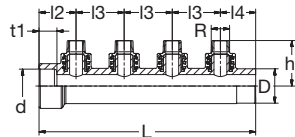
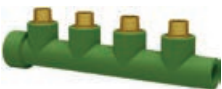

G 8241g PP-R-RG Verteiler AG-keg kaskadierbar grün  
PP-R-Bronze Manifold male-thread-con cascadable green

Teil / Item	d/D x Rp x n [mm x Inch]	L [mm]	l2 [mm]	l3 [mm]	l4 [mm]	t1 [mm]	t2 [mm]	h [mm]	KG	VE1	VE2
5R84 0873 11	32 x 1/2 x 4	250	43	56	41	18	15	50	0,43	1	25
5R84 0973 11	40 x 1/2 x 4	250	43	56	41	20,5	15	53	0,47	1	20
5R82 1175 11	63 x 3/4 x 2	434	148	204	82	27,5	15	75	0,46	1	15

n = Anzahl der Abgänge • Numbers of outlets.

### 3.02.09 Kugelhähne • Ball valves

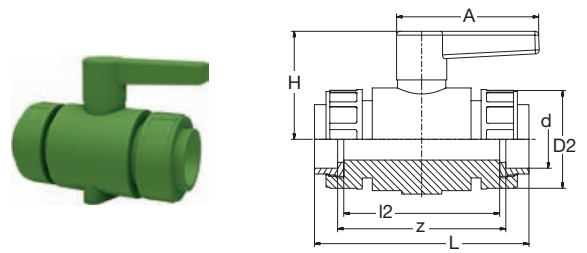
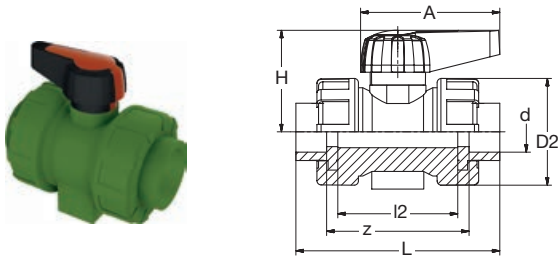

G 8852B PP-R Kugelhahn verschraubt Runddichtring-EPDM grün  
PP-R Ball valve with union-nuts O-Ring-gasket-EPDM green

Teil / Item	d [mm]	D2 [mm]	L [mm]	l2 [mm]	H [mm]	A [mm]	z [mm]	KG	VE1	VE2
591V 0600 21	20	50,5	96	56,5	48	66,5	67	0,12	1	-
591V 0700 21	25	59	109	65	57	81,5	77	0,19	1	-
591V 0800 21	32	70,5	119	71	65	81,5	83	0,28	1	-
591V 0900 21	40	86	141	85,5	83,5	91,5	100	0,44	1	-
591V 1000 21	50	99,5	153	89	89,5	91,5	106	0,54	1	-
591V 1100 21	63	126	172	101	115	143	117	0,93	1	-

G 8852 PP-R Kugelhahn verschraubt Runddichtring-EPDM grün  
PP-R Ball valve with union-nuts O-Ring-gasket-EPDM green

Teil / Item	d [mm]	D2 [mm]	L [mm]	l2 [mm]	H [mm]	A [mm]	z [mm]	KG	VE1	VE2
591V 1200 21	75	128,0	275	205	137	186	213	2,57	1	4

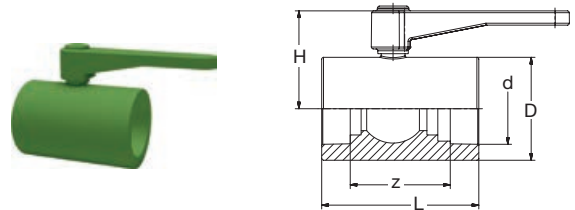
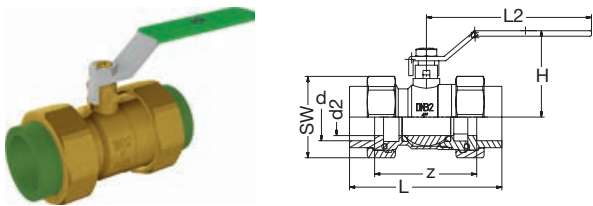

PP-R Kugelhahn-Ms verschraubt Runddichtring-EPDM grün  
PP-R Ball valve Brass with union-nuts O-Ring-gasket-EPDM green

Teil / Item	d [mm]	d2 [mm]	L [mm]	L2 [mm]	H [mm]	z [mm]	SW [mm]	KG	VE1	VE2
5MKV 0600 21	20	15	85	87	41	55	37	0,33	1	-
5MKV 0700 21	25	20	94	87	45	64	46	0,50	1	-
5MKV 0800 21	32	25	103	112	58	69	52	0,71	1	-

G 8850 PP-R Kugelhahn grün  
PP-R Ball valve green

Teil / Item	d [mm]	D [mm]	L [mm]	H [mm]	z [mm]	KG	VE1	VE2
5911 0700 21	25	37	78	72	46	0,215	1	-
5911 0800 21	32	48	91	56	55	0,349	1	-
5911 1200 21	75	108	166	98	106	1,90	1	-

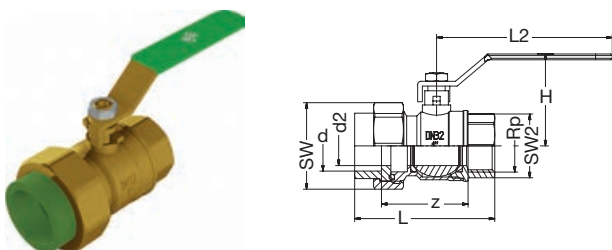

PP-R Ü-Kugelhahn-Ms IG-zyl verschraubt Runddichtring-EPDM grün  
PP-R Transition-Ball valve Brass female-thread-cyl with union-nuts O-Ring-gasket-EPDM green

Teil / Item	dx Rp [mm x Inch]	d2 [mm]	L [mm]	L2 [mm]	H [mm]	z [mm]	SW [mm]	SW2 [mm]	KG	VE1	VE2
5MKV 0643 21	20 x 1/2	15	71	87	41	42	37	26	0,23	1	-
5MKV 0745 21	25 x 3/4	20	80	87	45	50	46	32	0,39	1	-
5MKV 0846 21	32 x 1	25	89	112	58	54	52	38	0,59	1	-

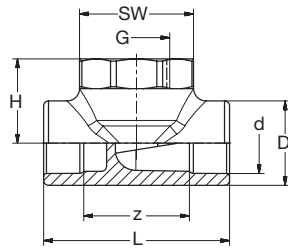
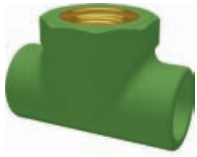

G 8599a PP-R-RG Ventil Geradsitz Unterteil IG-zyl grün  
PP-R-Bronze Valve straight bottom part female -thread-cyl green

Teil / Item	d x G [mm]	D [mm]	L [mm]	H [mm]	z [mm]	SW [mm]	KG	VE1	VE2
5RG1 06U0 11	20 x 3/4	29	75	34	46	46	0,110	5	-
5RG1 07U0 11	25 x 3/4	34	75	34	43	46	0,117	5	-
5RG1 08U0 11	32 x 3/4	43	75	34	38	46	0,134	5	-

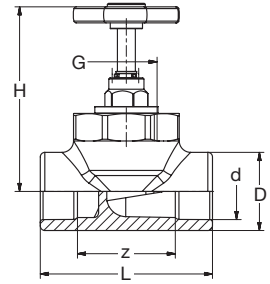

G 8599c PP-R-RG Ventil Geradsitz mit Handrad grün  
PP-R-Bronze Valve straight with hand wheel green

Teil / Item	d x G [mm]	D [mm]	L [mm]	H [mm]	z [mm]	KG	VE1	VE2
5RG1 060H 11	20 x 3/4	34	75	69	46	0,29	1	-
5RG1 070H 11	25 x 3/4	34	75	69	43	0,29	1	-
5RG1 080H 11	32 x 3/4	43	75	69	39	0,32	1	-

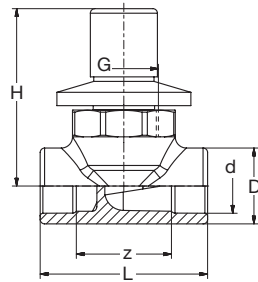
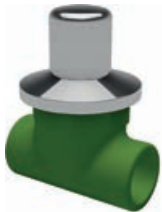

G 8599b PP-R-RG Ventil Geradsitz UP mit Flügelrad + Kappe grün  
PP-R-Bronze Valve straight concealed with winged wheel + cap green

Teil / Item	d x G [mm]	D [mm]	L [mm]	H [mm]	z [mm]	KG	VE1	VE2
5RG1 060K 11	20 x 3/4	29	75	63	46	0,286	1	-
5RG1 070K 11	25 x 3/4	34	75	63	43	0,275	1	-
5RG1 080K 11	32 x 3/4	43	75	63	38	0,298	1	-

Mit verchromter Rosette 70 mm.  
With chromed rosette 70 mm.

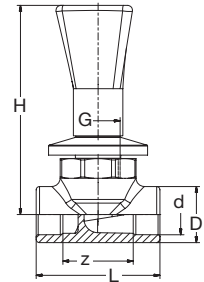

G 8599d PP-R-RG Ventil Geradsitz UP mit Drehgriff grün  
PP-R-Bronze Valve straight concealed with handle bar green

Teil / Item	d x G [mm]	D [mm]	L [mm]	H [mm]	z [mm]	KG	VE1	VE2
5RG1 060G 11	20 x 3/4	29	75	112	46	0,330	1	-
5RG1 070G 11	25 x 3/4	34	75	112	43	0,332	1	-
5RG1 080G 11	32 x 3/4	43	75	112	38	0,320	1	-

Mit verchromter Rosette 70 mm.  
With chromed rosette 70 mm.

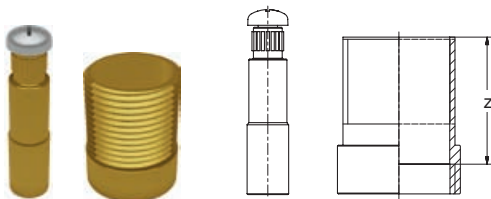

G 8599v Ventil Geradsitz UP Verlängerungsset 30mm  
Valve straight concealed prolongation-set 30mm

Teil / Item	L [mm]	KG	VE1	VE2
9902 0004 09	30	0,15	1	-

Bestehend aus: Gewindehülse, Achsverlängerung und Schraube.  
Consists of: threaded sleeve, axle extension and screw.

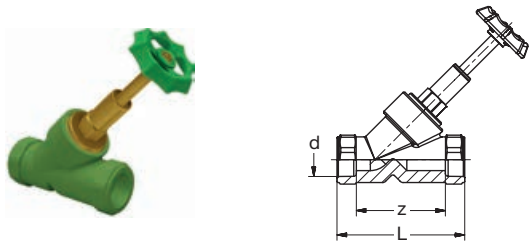

G 8700 PP-R-RG Ventil Schrägsitz mit Metallsitz grün  
G 8700/1 PP-R-Bronze Valve angle with metal seat green

Teil / Item	d [mm]	L [mm]	z [mm]	KG	VE1	VE2
5RS1 0600 11	20	115	86	0,31	1	-
5RS1 0700 11	25	115	83	0,31	1	-
5RS1 0800 11	32	120	84	0,49	1	-
5RS1 0900 11	40	145	104	0,73	1	-

**mit Rückflussverhinderer • with back-flow-preventor**

5RS1 060R 11	20	115	86	0,26	1	-
5RS1 070R 11	25	115	83	0,29	1	-
5RS1 080R 11	32	120	84	0,44	1	-
5RS1 090R 11	40	145	104	0,60	1	-

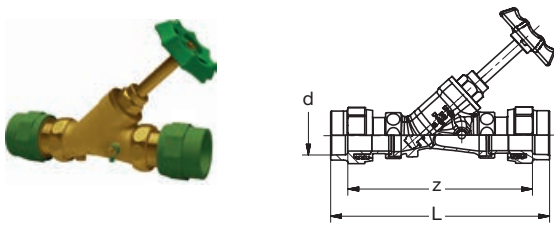

G 8600 PP-R-RG Ventil Schrägsitz-Ms verschraubt grün  
G 8600/1 PP-R-Bronze Valve angle-Brass union-nuts green

Teil / Item	d [mm]	L [mm]	z [mm]	KG	VE1	VE2
<b>mit Entleerung • with drainage</b>						
5MSV 060E 11	20			0,65	1	-
5MSV 070E 11	25			0,94	1	-
5MSV 080E 11	32			1,50	1	-
5MSV 090E 11	40			2,30	1	-
5MSV 100E 11	50	298	251	2,82	1	-
5MSV 110E 11	63	347	292	4,33	1	-

**mit Rückflussverhinderer • with back-flow-preventor**

5MSV 060R 11	20			0,65	1	-
5MSV 070R 11	25			0,94	1	-
5MSV 080R 11	32			1,50	1	-
5MSV 090R 11	40			2,30	1	-
5MSV 100R 11	50	298	251	2,82	1	-
5MSV 110R 11	63	347	292	4,33	1	-

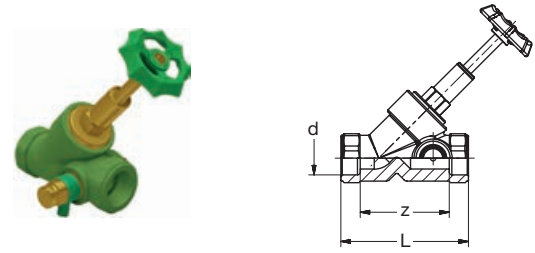

G 8800 PP-R-RG Ventil Schrägsitz mit Metallsitz + Entleerung + Prüfstopfen grün  
PP-R-Bronze Valve angle with metal seat + drainage + test-plug green

Teil / Item	d [mm]	L [mm]	z [mm]	KG	VE1	VE2
5RS1 060E 11	20	115	86	0,38	1	-
5RS1 070E 11	25	115	83	0,39	1	-
5RS1 080E 11	32	120	84	0,56	1	-
5RS1 090E 11	40	145	104	0,74	1	-

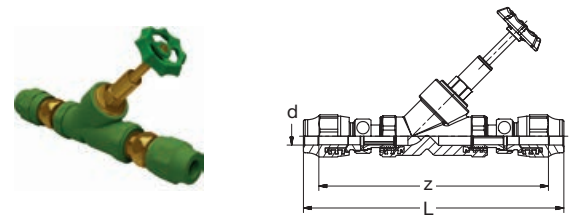

G 8655 PP-R-RG Ventil Schrägsitz mit Metallsitz verschraubt grün  
G 8655/1 PP-R-Bronze Valve angle with metal seat union-nuts green

Teil / Item	d [mm]	L [mm]	z [mm]	KG	VE1	VE2
<b>mit Entleerung + Prüfstopfen • with drainage + test plug</b>						
5RSV 0600 11	20	258	229	0,76	1	-
5RSV 0700 11	25	261	229	0,78	1	-
5RSV 0800 11	32	294	258	1,18	1	-
5RSV 0900 11	40	336	295	1,98	1	-

**mit Rückflussverhinderer • with back-flow-preventor**

5RSV 060R 11	20	258	229	0,57	1	-
5RSV 070R 11	25	261	229	0,58	1	-
5RSV 080R 11	32	294	258	1,18	1	-
5RSV 090R 11	40	336	295	1,96	1	-

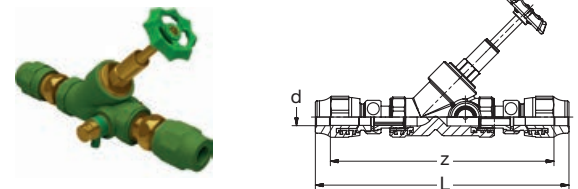

G 8650 PP-R-RG Ventil Schrägsitz mit Entleerung + Prüfstopfen verschraubt grün  
PP-R-Bronze Valve angle with drainage + test-plug and union-nuts green

Teil / Item	d [mm]	L [mm]	z [mm]	KG	VE1	VE2
5RSV 060E 11	20	258	229	0,53	1	-
5RSV 070E 11	25	261	229	0,77	1	-
5RSV 080E 11	32	294	258	1,09	1	-
5RSV 090E 11	40	336	295	1,94	1	-



## 4 PP-RCT

PP-RCT ist eine neue Polypropylen-Werkstoffgeneration. Dank Ihrer Struktur können Rohre und Formteile mit höherer hydraulischer Kapazität oder mit höherer Druckbelastbarkeit hergestellt werden. Das heißt, stellt man – für den gleichen Einsatzfall – die Rohre dünnwandiger her, haben sie bei gleichbleibendem Außendurchmesser eine höhere Durchflussleistung. Bei der Konzeption der Rohrsysteme kann somit der Außendurchmesser bei fast gleichem Innendurchmesser um eine Dimension reduziert werden.

Die Druckbelastbarkeit von PP-RCT ist deutlich höher als bei PP-R; z.B. ist bei einer Anwendungstemperatur von 70°C ein bis zu 60% höherer Druck möglich.

### Eigenschaften

- Hohe chemische Beständigkeit
- Korrosionsbeständigkeit
- Hervorragende Verarbeitbarkeit

### Werkstoff

PP-RCT (Polypropylen-Random-Copolymer Temperature resistant) mit modifizierter Kristallstruktur (beta nukleiert) und erhöhter Temperaturbeständigkeit, RAL 6024 Verkehrsgrün.

### Verbindungstechnik

- Heizelement-Muffen-Schweißung
- Heizelement-Stumpf-Schweißung
- Heizwendel-Muffen-Schweißung
- Flanschverbindung



## 4 PP-RCT

PP-RCT is a new generation of Polypropylene material. Thanks to its structure, pipes and fittings can be produced with higher hydraulic capacity or with higher compressive strength. This means that – for the same application case – if the pipes are produced with thinner walls, they have higher flow capacity with a consistent diameter. With the conception of the pipe systems, the outer diameter can therefore be reduced by one dimension with virtually the same inner diameter.

The compressive strength of PP-RCT is significantly higher than with PP-R; e.g. with an application temperature of 70°C higher pressure of up to 60% is possible.

### Properties:

- Good resistance to chemicals
- Corrosion resistance
- Excellent processing capability

### Material:

PP-RCT (Polypropylene-Random-Copolymer Temperature resistant) with a modified crystal structure (beta nucleated) and increased temperature resistance, RAL 6024 traffic green.

### Joining technology:

- Socket-welding
- Butt-welding
- Electrofusion socket-welding
- Flange connection



## 4.01 Rohre • Pipes

4.01.01 Rohre einlagig  
Pipes single-layer **RCT 4**



4.01.02 Rohre mehrlagig  
Pipes multi-layer **RCT 7**



4.01.03 Sonderrohre • Special Pipes **RCT 10**

## 4.02 Formteile Muffen-Schweißen Fittings socket-welding

4.02.01 Bögen + Winkel  
Bends + Elbows **RCT 12**

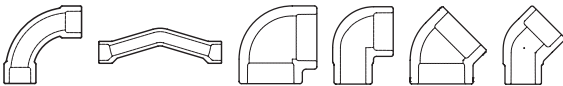

4.02.02 T-Stücke + Abzweige  
Tee's + Branches **RCT 14**

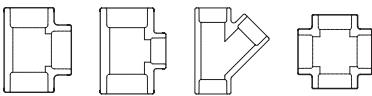

4.02.03 Reduktionen, Muffen, Kappen  
Reducers, Sockets, Caps **RCT 16**

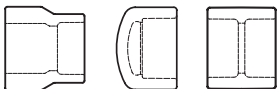

4.02.04 Übergänge • Transitions **RCT 17**

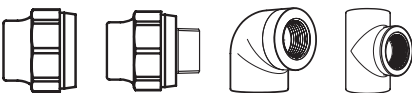

4.02.05 Übergänge Wand  
Transitions wall **RCT 19**



4.02.06 Verschraubungen • Unions **RCT 21**

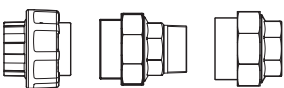

4.02.07 Flanschverbindung  
Flange connection **RCT 24**

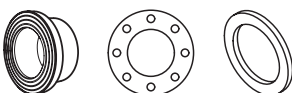

4.02.08 Einschweißsättel  
Weld-in-saddles **RCT 25**



4.02.09 Verteiler • Manifolds **RCT 27**



4.02.10 Kugelhähne • Ball valves **RCT 28**

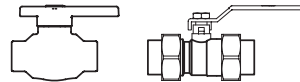

4.02.11 Ventile • Valves **RCT 29**



## 4.03 Formteile Stumpf-Schweißen Fittings butt-welding

4.03.01 Winkel • Elbows **RCT 31**

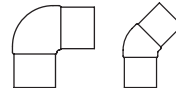

4.03.02 T-Stücke • Tee's **RCT 32**

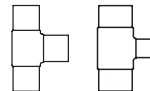

4.03.03 Reduktionen, Kappen  
Reducers, Caps **RCT 33**

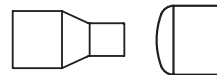

4.03.04 Flanschverbindung  
Flange connection **RCT 34**

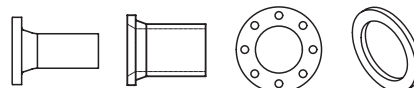

## 4.04 Formteile Heizwendel-Muffen-Schweißen Fittings electrofusion-socket-welding

**RCT 36**



**4.01.01 Rohre einlagig • Pipes single-layer**
**POWERTEC-CT (G 8200B)**
**Beschreibung**

PP-RCT Druckrohr POWERTEC-CT, einschichtig, SDR7,4. Homogenes Rohr für sehr hohe Drücke und hohe Temperaturen.

**Werkstoff**

P-RCT (Polypropylen Random-Copolymer Temperature resistant) mit modifizierter Kristallstruktur (beta nukleiert) und erhöhter Temperaturbeständigkeit, Borealis RA7050, Farbe RAL 6024 Verkehrsgrün.

Das Material entspricht den Anforderungen der aktuellen KTW-Leitlinie des Umweltbundesamtes (UBA).

**Geometrische Eigenschaften**

Außendurchmesser und Wanddicke entsprechend DIN 8077 und DIN EN ISO 15874.

**Betriebsdruck**

20°C / 2,0 MPa • 70°C / 1,0 MPa.

**Ausführung**

Geeignet für Heizelement-Muffen-Schweißung, Heizelement-Stumpf-Schweißung und Heizwendel-Muffen-Schweißung nach DVS Richtlinie 2207. Schweiß-Geräte und Schweiß-Werkzeuge sollten der DVS Richtlinie 2208 entsprechen.

**Zertifizierung**

B-R Rohre unterliegen regelmäßigen internen und externen Qualitätskontrollen. Die Rohre erfüllen die Anforderungen der DIN Certco Richtlinie ZP 10.25.1, NSF14 + 61, AENOR und ÖVGW.

**Lieferung**

In 4 m Stangen; abgepackt in Bunden. Alle Bunde sind in schwarzer UV-Schutz-Schlauchfolie verpackt. Abgabe erfolgt nur in kompletten Verpackungseinheiten (VEs).

**Description**

PP-RCT Pressure pipe POWERTEC-CT, single-layer, SDR7,4. Homogeneous pipe for very high pressures and high temperatures.

**Material**

PP-RCT (Polypropylene Random-Copolymer Temperature resistant) with modified crystalline structure (beta nucleated) and increased temperature resistance, colour RAL 6024 traffic green.

The material complies with the requirements of the KTW guideline of the German Federal Environmental Agency (UBA).

**Geometric Properties**

Outside diameter and wall thickness according to DIN 8077 and DIN EN ISO 15874.

**Operating Pressure**

20°C / 2,0 MPa • 70°C / 1,0 MPa.

**Type**

Suitable for socket-welding, butt-welding and electrofusion-socket-welding according to DVS technical code 2207. Welding equipment according to DVS technical code 2208.

**Certification**

B-R pipes succumb frequent internal and external quality controls. The pipes fulfill the requirements of the DIN Certco guideline ZP 10.25.1 and NSF14 + 61, AENOR and ÖVGW.

**Delivery**

In 4 m rods; packed in bundles. All bundles are packed in black UV-protection-foil. Supply only in complete packing units (VEs).

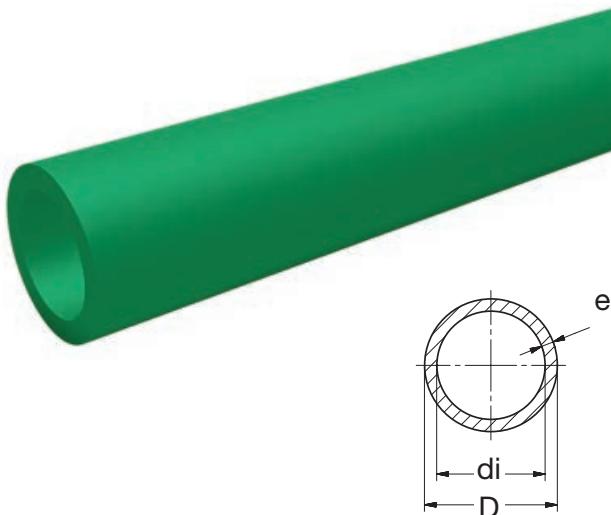

G 8200B PP-RCT Druckrohr **POWERTEC-CT** 2,0MPa **SDR7,4** grün  
 PP-RCT Pressure-Pipe **POWERTEC-CT** 2,0 MPa **SDR7,4** green

Teil / Item	D [mm]	e [mm]	DN [mm]	di [mm]	SDR	L [m]	KG [m]	VE1 [m]	VE2 [m]
<b>20°C / 2,0MPa • 70°C / 1,0MPa</b>									
7121 0640 11	20	2,8	15	14,4	7,4	4	0,18	100	
7121 0740 11	25	3,5	20	18,0	7,4	4	0,28	100	
7121 0840 11	32	4,4	25	23,2	7,4	4	0,46	60	
7121 0940 11	40	5,5	32	29,0	7,4	4	0,68	40	
7121 1040 11	50	6,9	40	36,2	7,4	4	1,09	20	
7121 1140 11	63	8,6	50	45,8	7,4	4	1,40	20	
7121 1240 11	75	10,3	-	54,4	7,4	4	1,96	8	
7121 1340 11	90	12,3	65	65,4	7,4	4	2,94	8	
7121 1440 11	110	15,1	80	79,8	7,4	4	4,36	8	
7121 1540 11	125	17,1	90	90,8	7,4	4	5,56	4	

**ECONTEC-CT (G 8160B)**
**Beschreibung**

PP-RCT Druckrohr ECONTEC-CT, einschichtig, SDR9 bis 11. Homogenes Rohr für hohe Drücke und hohe Temperaturen, bei gleichzeitigem hohem Durchfluss.

**Werkstoff**

PP-RCT (Polypropylen Random-Copolymer Temperature resistant) mit modifizierter Kristallstruktur (beta nukleiert) und erhöhter Temperaturbeständigkeit, Borealis RA7050, Farbe RAL 6024 Verkehrsgrün.  
Das Material entspricht den Anforderungen der aktuellen KTW-Leitlinie des Umweltbundesamtes (UBA).

**Geometrische Eigenschaften**

Außendurchmesser und Wanddicke entsprechend DIN 8077 und DIN EN ISO 15874.

**Betriebsdruck**

20°C / 1,6 MPa • 60°C / 0,8 MPa.

**Ausführung**

Geeignet für Heizelement-Muffen-Schweißung, Heizelement-Stumpf-Schweißung und Heizwendel-Muffen-Schweißung nach DVS Richtlinie 2207. Schweiß-Geräte und Schweiß-Werkzeuge sollten der DVS Richtlinie 2208 entsprechen.

**Zertifizierung**

B-R Rohre unterliegen regelmäßigen internen und externen Qualitätskontrollen. Die Rohre erfüllen die Anforderungen der DIN Certco Richtlinie ZP 10.25.1.

**Lieferung**

Bis D200 in 4 m Stangen und ab D250 in 5,8 m Stangen; abgepackt in Bündeln oder Einzelverpackt. Alle Rohre/Bünde sind in schwarzer UV-Schutz-Schlauchfolie verpackt. Abgabe erfolgt nur in kompletten Verpackungseinheiten (VE's).

**Description**

PP-RCT Pressure pipe ECONTEC-CT, single-layer, SDR9 up to 11. Homogeneous pipe for high pressures and high temperatures with simultaneous high flow.

**Material**

PP-RCT (Polypropylene Random-Copolymer Temperature resistant) with modified crystalline structure (beta nucleated) and increased temperature resistance, colour RAL 6024 traffic green.  
The material complies with the requirements of the KTW guideline of the German Federal Environmental Agency (UBA).

**Geometric Properties**

Outside diameter and wall thickness according to DIN 8077 and DIN EN ISO 15874.

**Operating Pressure**

20°C / 1,6 MPa • 60°C / 0,8 MPa.

**Type**

Suitable for socket-welding, butt-welding and electrofusion-socket-welding according to DVS technical code 2207. Welding equipment according to DVS technical code 2208.

**Certification**

B-R pipes succumb frequent internal and external quality controls. The pipes fulfill the requirements of the DIN Certco guideline ZP 10.25.1.

**Delivery**

Up to D200 in 4 m rods and from D250 in 5,8 m rods; packed in bundles or individual. All pipes/bundles are packed in black UV-protection-foil. Supply only in complete packing units (VE's).

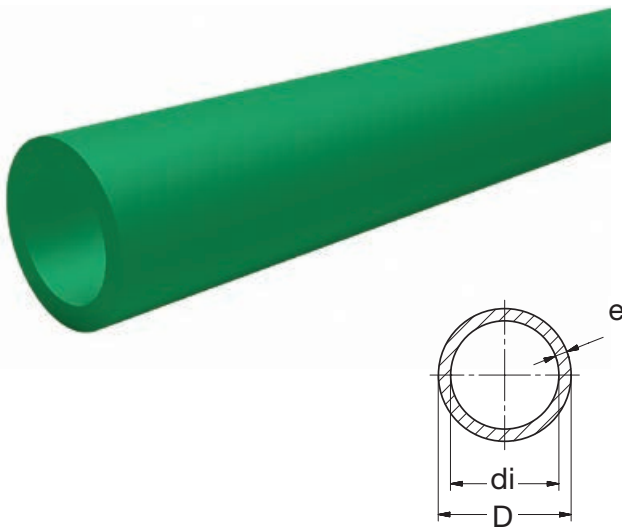

G 8160B PP-RCT Druckrohr **ECONTEC-CT** 1,6MPa grün  
PP-RCT Pressure-Pipe **ECONTEC-CT** 1,6Mpa green

Teil / Item	D [mm]	e [mm]	DN [mm]	di [mm]	SDR	L [m]	KG [m]	VE1 [m]	VE2 [m]
7131 0640 11	20	2,3	15	15,4	9	4	0,14	100	
7131 0740 11	25	2,8	20	19,4	9	4	0,21	100	
7141 0840 11	32	2,9	25	26,2	11	4	0,29	60	
7141 0940 11	40	3,7	32	32,6	11	4	0,42	40	
7141 1040 11	50	4,6	40	40,8	11	4	0,64	20	
7141 1140 11	63	5,8	50	51,4	11	4	1,40	20	
7141 1240 11	75	6,8	-	61,4	11	4	1,44	8	
7141 1340 11	90	8,2	65	73,6	11	4	1,03	8	
7141 1440 11	110	10	80	90	11	4	3,08	8	
7141 1540 11	125	11,4	100	102,2	11	4	3,91	4	
7141 1740 11	160	14,6	125	130,8	11	4	6,33	4	
7141 1940 11	200	18,2	160	163,6	11	4	9,95	4	
7141 2158 11	250	22,7	200	204,6	11	5,8	15,3	5,8	
7141 2358 11	315	28,6	250	257,8	11	5,8	24,6	5,8	
7141 2458 11	355	32,2	300	290,6	11	5,8	31,2	5,8	
7141 2558 11	400	36,3	-	327,4	11	5,8	39,6	5,8	
7141 2658 11	450	40,9	350	368,2	11	5,8	50,1	5,8	
7141 2758 11	500	45,4	400	409,2	11	5,8	61,7	5,8	

## CYCLETEC-CT (L 8160B)

### Beschreibung

PP-RCT Druckrohr CYCLETEC-CT, einschichtig mit äußerer Deckschicht in lila, SDR 9 bis 11. Homogenes Rohr für hohe Drücke und hohe Temperaturen, bei gleichzeitigem hohem Durchfluss.

Spezielle Farbe und Beschriftung zur Identifikation der Leitung als Nicht-Trinkwasser. Für Anwendungen mit z.B. Regen-, regeneriertem oder wiederverwendetem Wasser zur Reinigung, Spülung, Waschen oder zur Bewässerung.

### Werkstoff

PP-RCT (Polypropylen Random-Copolymer Temperature resistant) mit modifizierter Kristallstruktur (beta nukleiert) und erhöhter Temperaturbeständigkeit, Borealis RA7050, Farbe RAL 6024 Verkehrsgrün.

Das Material entspricht den Anforderungen der aktuellen KTW-Leitlinie des Umweltbundesamtes (UBA). Äußere Deckschicht aus PP-R in lila.

### Geometrische Eigenschaften

Außendurchmesser und Wanddicke in Anlehnung an DIN 8077 und DIN EN ISO 15874.

### Betriebsdruck

20°C / 1,6 MPa • 60°C / 0,8 MPa.

### Ausführung

Geeignet für Heizelement-Muffen-Schweißung, Heizelement-Stumpf-Schweißung und Heizwendel-Muffen-Schweißung nach DVS Richtlinie 2207. Schweiß-Geräte und Schweiß-Werkzeuge sollten der DVS Richtlinie 2208 entsprechen.

### Zertifizierung

B-R Rohre unterliegen regelmäßigen internen und externen Qualitätskontrollen.

### Lieferung

In 4 m Stangen; abgepackt in Bündeln oder Einzelverpackt. Alle Rohre/Bünde sind in schwarzer UV-Schutz-Schlauchfolie verpackt. Abgabe erfolgt nur in kompletten Verpackungseinheiten (VEs).

### Description

PP-RCT Pressure pipe CYCLETEC-CT, single-layer with outer layer in lilac, SDR9 up to 11. Homogeneous pipe for high pressures and high temperatures with simultaneous high flow.

Color-coded and labeled to identify it as a non-potable line. For applications like rain, recycled or reclaimed water for cleaning, flush, laundry or irrigation.

### Material

PP-RCT (Polypropylene Random-Copolymer Temperature resistant) with modified crystalline structure (beta nucleated) and increased temperature resistance, colour RAL 6024 traffic green.

The material complies with the requirements of the KTW guideline of the German Federal Environmental Agency (UBA). Outer layer made of PP-R in lilac color.

### Geometric Properties

Outside diameter and wall thickness according to DIN 8077 and DIN EN ISO 15874.

### Operating Pressure

20°C / 1,6 MPa • 60°C / 0,8 MPa.

### Type

Suitable for socket-welding, butt-welding and electrofusion-socket-welding according to DVS technical code 2207. Welding equipment according to DVS technical code 2208.

### Certification

B-R pipes succumb frequent internal and external quality controls.

### Delivery

In 4 m rods; packed in bundles or individual. All pipes/bundles are packed in black UV-protection-foil. Supply only in complete packing units (VEs).

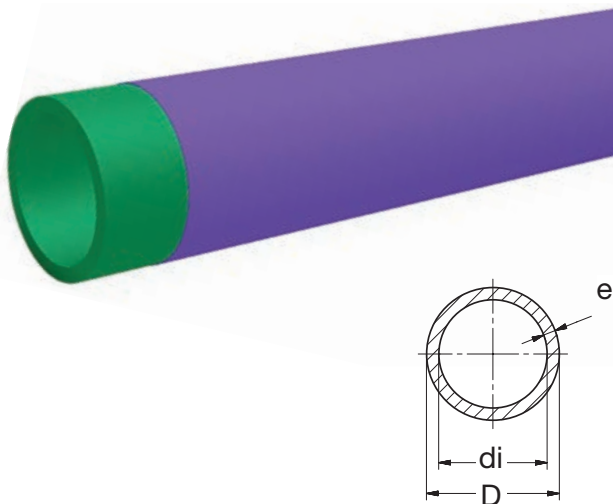

L 8160B PP-RCT Druckrohr **CYCLETEC-CT** 1.6MPa lila 4m  
PP-RCT Pressure pipe **CYCLETEC-CT** 1.6MPa lilac 4m

Teil / Item	D [mm]	e [mm]	DN [mm]	di [mm]	SDR	L [m]	kg [m]	VE1 [m]	VE2 [m]
<b>20°C / 1,6MPa • 60°C / 0,8MPa</b>									
7132 0640 17	20	2,3	15	15,4	9	4	1,14	100	
7132 0740 17	25	2,8	20	19,4	9	4	0,21	100	
7142 0840 17	32	2,9	25	26,2	11	4	0,29	60	
7142 0940 17	40	3,7	32	32,6	11	4	0,42	40	
7142 1040 17	50	4,6	40	40,8	11	4	0,64	20	
7142 1140 17	63	5,8	50	51,4	11	4	1,40	20	
7142 1240 17	75	6,8	-	61,4	11	4	1,44	8	
7142 1340 17	90	8,2	65	73,6	11	4	2,03	8	
7142 1440 17	110	10,0	80	90,0	11	4	3,08	8	
7142 1540 17	125	11,4	100	102,2	11	4	3,91	4	

## STABITEC-CT (G 8215B)

### Beschreibung

PP-RCT Druckrohr STABITEC-CT, mehrschichtig, mit äußerer gelochter Aluminium Deckschicht zur Reduzierung der axialen Ausdehnung, SDR 7,4 bis SDR9. Homogenes Rohr für hohe Drücke und hohe Temperaturen, bei gleichzeitigem hohen Durchfluss und stark reduzierter Längenausdehnung. Vor dem Schweißen muss die Aluminiumschicht entfernt werden.

### Werkstoff

PP-RCT (Polypropylen Random-Copolymer Temperature resistant) mit modifizierter Kristallstruktur (beta nukleiert) und erhöhter Temperaturbeständigkeit, Borealis RA7050, Farbe RAL 6024 Verkehrsgrün. Das Material entspricht den Anforderungen der aktuellen KTW-Leitlinie des Umweltbundesamtes (UBA). Äußere PP-RCT-Schutz-Deckschicht in grün.

### Geometrische Eigenschaften

Außendurchmesser und Wanddicke des Innenrohres entsprechend DIN 8077 und DIN EN ISO 15874.

### Betriebsdruck

20°C / 2,0 MPa • 70°C / 1,0 MPa.

### Ausführung

Geeignet für Heizelement-Muffen-Schweißung, Heizelement-Stumpf-Schweißung und Heizwendel-Muffen-Schweißung nach DVS Richtlinie 2207. Schweiß-Geräte und Schweiß-Werkzeuge sollten der DVS Richtlinie 2208 entsprechen.

### Zertifizierung

B-R Rohre unterliegen regelmäßigen internen und externen Qualitätskontrollen. Die Rohre erfüllen die Anforderungen der DIN Certco Richtlinie ZP 9.18.1.

### Lieferung

In 4 m Stangen; abgepackt in Bündeln. Alle Bündel sind in schwarzer UV-Schutz-Schlauchfolie verpackt. Abgabe erfolgt nur in kompletten Verpackungseinheiten (VEs).

### Description

PP-RCT Pressure pipe STABITEC-CT, multi-layer, with outer perforated Aluminium-layer for reduced axial expansion, SDR7,4 up to 9. Homogeneous pipe for high pressures and high temperatures, with simultaneous high flow and highly reduced expansion. The Aluminium-layer must be removed prior to welding

### Material

PP-RCT (Polypropylene Random-Copolymer Temperature resistant) with modified crystalline structure (beta nucleated) and increased temperature resistance, colour RAL 6024 traffic green. The material complies with the requirements of the KTW guideline of the German Federal Environmental Agency (UBA). Outer PP-RCT-protection-layer in green color.

### Geometric Properties

Outside diameter and wall thickness of the inner pipe according to DIN 8077 and DIN EN ISO 15874.

### Operating Pressure

20°C / 2,0 MPa • 70°C / 1,0 MPa.

### Type

Suitable for socket-welding, butt-welding and electrofusion-socket-welding according to DVS technical code 2207. Welding equipment according to DVS technical code 2208.

### Certification

B-R pipes succumb frequent internal and external quality controls. The pipes fulfill the requirements of the DIN Certco guideline ZP 9.18.1.

### Delivery

In 4 m rods; packed in bundles. All bundles are packed in black UV-protection-foil. Supply only in complete packing units (VEs).

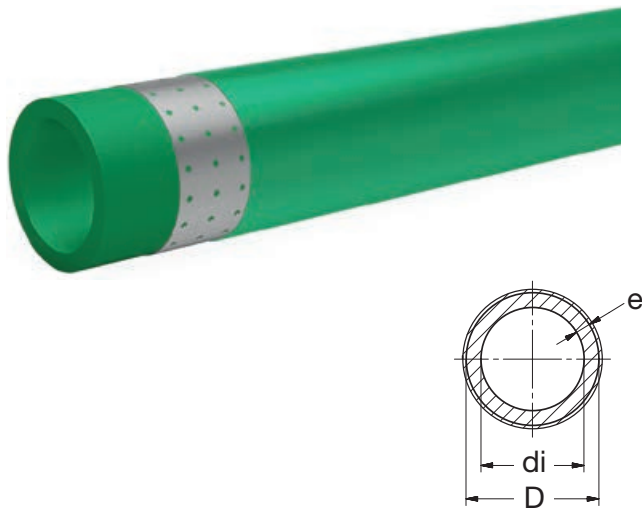

G 8215B PP-RCT-Alu Druckrohr **STABITEC-CT** 2,0MPa grün 4m  
 PP-RCT-Alu Pressure-Pipe **STABITEC-CT** 2,0MPa green 4m

Teil / Item	D [mm]	e [mm]	DN [mm]	di [mm]	SDR	L [m]	kg [m]	VE1 [m]	VE2 [m]
<b>20°C / 2,0MPa • 70°C / 1,0MPa</b>									
52S1 0540 11	16	2,2	12	11,6	7,4*	4	0,16	100	
72S1 0640 11	20	2,8	15	14,4	7,4	4	0,22	100	
72S1 0740 11	25	2,8	20	19,4	9	4	0,29	100	
72S1 0840 11	32	3,6	25	24,8	9	4	0,55	60	
72S1 0940 11	40	4,5	32	31,0	9	4	0,64	40	
72S1 1040 11	50	5,6	40	38,8	9	4	0,94	20	
72S1 1140 11	63	7,1	50	48,8	9	4	1,47	20	
72S1 1240 11	75	8,4	-	58,2	9	4	1,93	8	
72S1 1340 11	90	10,1	65	69,8	9	4	3,01	8	
72S1 1440 11	110	12,3	80	85,4	9	4	4,29	8	
72S1 1540 11	125	14,0	100	97,0	9	4	5,28	4	

\* PP-R

## WATERTEC (G 8200FW)

### Beschreibung

PP-RCT Druckrohr WATERTEC, mehrlagig, mit Faser-Mittelschicht zur Reduzierung der axialen Ausdehnung, SDR7,4 bis SDR11.

Für hohe Drücke und hohe Temperaturen, bei gleichzeitigem hohem Durchfluss und reduzierter Längenausdehnung.

Faser-Rohre können, analog zu normalen Rohren, ohne vorherigen Bearbeitungsschritt direkt verschweißt werden.

### Werkstoff

PP-RCT (Polypropylen Random-Copolymer Temperature resistant) mit modifizierter Kristallstruktur (beta nukleiert) und erhöhter Temperaturbeständigkeit, Borealis RA7050, Farbe RAL 6024 Verkehrsgrün. Das Material entspricht den Anforderungen der aktuellen KTW-Leitlinie des Umweltbundesamtes (UBA).

### Geometrische Eigenschaften

Außendurchmesser und Wanddicke in Anlehnung an DIN 8077 und DIN EN ISO 15874.

### Betriebsdruck

Bis D125 = 2,0 MPa / 20°C • 1,0 MPa / 70°C.

Ab D160 = 1,6 MPa / 20°C • 0,8 MPa / 70°C.

### Ausführung

Geeignet für Heizelement-Muffen-Schweißung, Heizelement-Stumpf-Schweißung und Heizwendel-Muffen-Schweißung nach DVS Richtlinie 2207. Schweiß-Geräte und Schweiß-Werkzeuge sollten der DVS Richtlinie 2208 entsprechen.

### Zertifizierung

B-R Rohre unterliegen regelmäßigen internen und externen Qualitätskontrollen. Die Rohre erfüllen die Anforderungen der DIN Certco Richtlinie ZP 9.12.1 und NSF14 + 61.

### Lieferung

Bis D200 in 4 m Stangen und ab D250 in 5,8 m Stangen; abgepackt in Bündeln oder Einzelverpackt. Alle Rohre/Bünde sind in schwarzer UV-Schutz-Schlauchfolie verpackt. Abgabe erfolgt nur in kompletten Verpackungseinheiten (VE's).

### Description

PP-RCT Pressure pipe WATERTEC, multi-layer, with fiber-middle-layer for reduced axial expansion, SDR7,4 up to 11.

For high pressures and high temperatures with simultaneous high flow and reduced expansion.

Fiber-pipes can be, analogue to normal pipes, directly welded without a prior processing step.

### Material

PP-RCT (Polypropylene Random-Copolymer Temperature resistant) with modified crystalline structure (beta nucleated) and increased temperature resistance, colour RAL 6024 traffic green. The material complies with the requirements of the KTW guideline of the German Federal Environmental Agency (UBA).

### Geometric Properties

Outside diameter and wall thickness according to DIN 8077 and DIN EN ISO 15874.

### Operating Pressure

Up to D125 = 2,0 MPa / 20°C • 1,0 MPa / 70°C.

From D160 = 1,6 MPa / 20°C • 1,0 MPa / 70°C.

### Type

Suitable for socket-welding, butt-welding and electrofusion-socket-welding according to DVS technical code 2207. Welding equipment according to DVS technical code 2208.

### Certification

B-R pipes succumb frequent internal and external quality controls. The pipes fulfill the requirements of the DIN Certco guideline ZP 9.12.1 and NSF14 + 61.

### Delivery

Up to D200 in 4 m rods and from D250 in 5,8 m rods; packed in bundles or individual. All pipes/bundles are packed in black UV-protection-foil. Supply only in complete packing units (VE's).

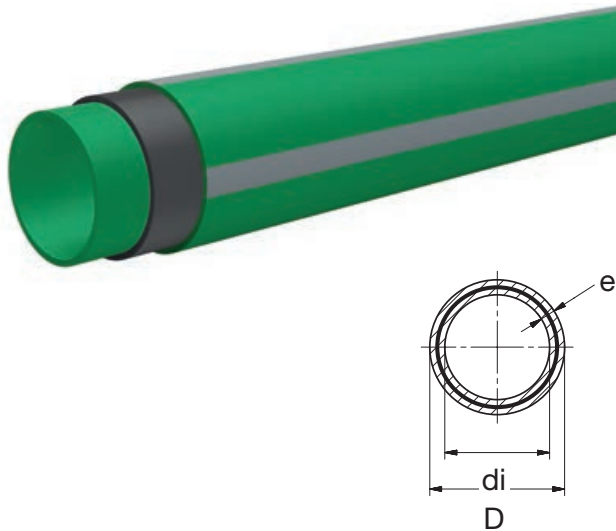

G 8200FW PP-RCT Druckrohr **WATERTEC** grün  
PP-RCT Pressure pipe **WATERTEC** green

Teil / Item	D [mm]	e [mm]	DN [mm]	di [mm]	SDR	L [m]	KG [m]	VE1 [m]	VE2 [m]
<b>20°C / 2.0MPa • 70°C / 1.0MPa</b>									
72W1 0640 11	20	2,8	15	14,4	7,4	4	0,15	100	
72W1 0740 11	25	3,5	20	18,0	7,4	4	0,23	100	
72W1 0840 11	32	3,6	25	24,8	9	4	0,34	60	
72W1 0940 11	40	4,5	32	31,0	9	4	0,51	40	
72W1 1040 11	50	5,6	40	38,8	9	4	0,75	20	
72W1 1140 11	63	7,1	50	48,8	9	4	1,24	20	
72W1 1240 11	75	8,4	-	58,2	9	4	1,70	8	
72W1 1340 11	90	10,1	65	69,8	9	4	2,45	8	
72W1 1440 11	110	12,3	80	85,4	9	4	3,65	8	
72W1 1540 11	125	14,0	100	97,0	9	4	4,48	4	
<b>20°C / 1.6MPa • 70°C / 0.8MPa</b>									
72W1 1740 11	160	14,6	125	130,8	11	4	6,76	4	
72W1 1940 11	200	18,2	160	163,6	11	4	10,6	4	
72W1 2158 11	250	22,7	200	204,6	11	5,8	16,2	5,8	
72W1 2358 11	315	28,6	250	257,8	11	5,8	25,4	5,8	
72W1 2458 11	355	32,2	300	290,6	11	5,8	36,5	5,8	
72W1 2558 11	400	36,3	-	327,4	11	5,8	40,6	5,8	
72W1 2658 11	450	40,9	350	368,2	11	5,8	57,3	5,8	
72W1 2758 11	500	45,4	400	409,2	11	5,8		5,8	

**CLIMATEC (G 8160FC)**
**CLIMATEC-blue (HC8160FC)\***
**Beschreibung**

PP-RCT Druckrohr CLIMATEC, mehrlagig, mit Faser-Mittelschicht zur Reduzierung der axialen Ausdehnung, SDR 7,4 bis SDR17. Optional mit einer blauen Außenschicht lieferbar.

Für normale Drücke und hohe Temperaturen, sehr hohem Durchfluß und reduzierter Längenausdehnung.

Faser-Rohre können, analog zu normalen Rohren, ohne vorherigen Bearbeitungsschritt direkt verschweißt werden.

**Werkstoff**

PP-RCT (Polypropylen Random-Copolymer Temperature resistant) mit modifizierter Kristallstruktur (beta nukleiert) und erhöhter Temperaturbeständigkeit, Borealis RA7050, Farbe RAL 6024 Verkehrsgrün.

Das Material entspricht den Anforderungen der aktuellen KTW-Leitlinie des Umweltbundesamtes (UBA).

**Geometrische Eigenschaften**

Außendurchmesser und Wanddicke in Anlehnung an DIN 8077 und DIN EN ISO 15874.

**Betriebsdruck**

Bis D125 = 20°C / 1,6 MPa • 70°C / 0,8 MPa.

Ab D160 = 20°C / 1,0 MPa • 70°C / 0,5 MPa.

**Ausführung**

Geeignet für Heizelement-Muffen-Schweißung, Heizelement-Stumpf-Schweißung und Heizwendel-Muffen-Schweißung nach DVS Richtlinie 2207. Schweiß-Geräte und Schweiß-Werkzeuge sollten der DVS Richtlinie 2208 entsprechen.

**Zertifizierung**

B-R Rohre unterliegen regelmäßigen internen und externen Qualitätskontrollen. Die Rohre erfüllen die Anforderungen der DIN Certco Richtlinie ZP 9.12.1 und NSF14 + 61.

**Lieferung**

Bis D200 in 4 m Stangen und ab D250 in 5,8 m Stangen; abgepackt in Bündeln oder Einzelverpackt. Alle Rohre/Bünde sind in schwarzer UV-Schutz-Schlauchfolie verpackt. Abgabe erfolgt nur in kompletten Verpackungseinheiten (VE's).

**Description**

PP-RCT Pressure pipe CLIMATEC, multi-layer, with fiber-middle-layer for reduced axial expansion, SDR7,4 up to 17. Optionally available with a blue outer layer.

For normal pressures and high temperatures, very high flow and reduced expansion. Fiber-pipes can be, analogue to normal pipes, directly welded without a prior processing step.

**Material**

PP-RCT (Polypropylene Random-Copolymer Temperature resistant) with modified crystalline structure (beta nucleated) and increased temperature resistance, colour RAL 6024 traffic green.

The material complies with the requirements of the KTW guideline of the German Federal Environmental Agency (UBA).

**Geometric Properties**

Outside diameter and wall thickness according to DIN 8077 and DIN EN ISO 15874.

**Operating Pressure**

Up to D125 = 20°C / 1,6 MPa • 70°C / 0,8 MPa.

From D160 = 20°C / 1,0 MPa • 70°C / 0,5 MPa.

**Type**

Suitable for socket-welding, butt-welding and electrofusion-socket-welding according to DVS technical code 2207. Welding equipment according to DVS technical code 2208.

**Certification**

B-R pipes succumb frequent internal and external quality controls. The pipes fulfill the requirements of the DIN Certco guideline ZP 9.12.1 and NSF14 + 61.

**Delivery**

Up to D200 in 4 m rods and from D250 in 5,8 m rods; packed in bundles or individual. All pipes/bundles are packed in black UV-protection-foil. Supply only in complete packing units (VE's).

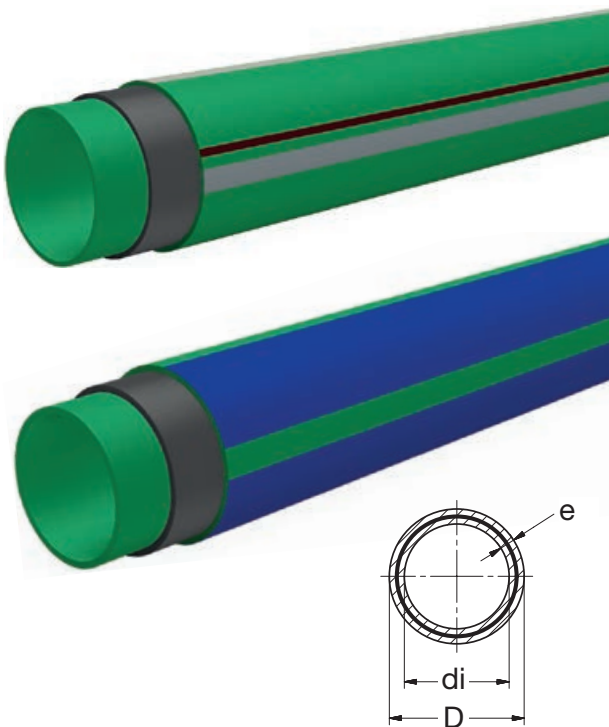

G 8160FC Grün/green		HC8160FC Blau/blue		PP-RCT Druckrohr <b>CLIMATEC</b> / <b>CLIMATEC-blue</b>		PP-RCT Pressure pipe <b>CLIMATEC</b> / <b>CLIMATEC-blue</b>					
Teil / Item	Teil / Item	D [mm]	e [mm]	DN [mm]	di [mm]	SDR	L [m]	KG [m]	VE1 [m]	VE2 [m]	
<b>20°C / 1.6MPa • 70°C / 0.8MPa</b>											
72C1 0640 11	72C2 0640 14	20	2,8	15	14,4	7,4	4	0,15	100		
72C1 0740 11	72C2 0740 14	25	3,5	20	18,0	7,4	4	0,24	100		
72C1 0840 11	72C2 0840 14	32	3,6	25	24,8	9	4	0,34	60		
72C1 0940 11	72C2 0940 14	40	3,7	32	32,6	11	4	0,44	40		
72C1 1040 11	72C2 1040 14	50	4,6	40	40,8	11	4	0,68	20		
72C1 1140 11	72C2 1140 14	63	5,8	50	51,4	11	4	1,00	20		
72C1 1240 11	72C2 1240 14	75	6,8	-	61,4	11	4	1,42	8		
72C1 1340 11	72C2 1340 14	90	8,2	65	73,6	11	4	2,04	8		
72C1 1440 11	72C2 1440 14	110	10,0	80	90,0	11	4	3,03	8		
72C1 1540 11	72C2 1540 14	125	11,4	100	102,2	11	4	3,35	4		
<b>20°C / 1.0MPa • 70°C / 0.5MPa</b>											
72C1 1740 11		160	9,5	150	141	17	4	4,64	4		
72C1 1940 11		200	11,9	180	176,2	17	4	7,32	4		
72C1 2158 11		250	14,8	220	220,4	17	5,8	11,1	5,8		
72C1 2358 11		315	18,7	250	277,6	17	5,8	17,2	5,8		
72C1 2458 11		355	21,2	300	312,6	17	5,8	21,9	5,8		
72C1 2558 11		400	23,7	350	352,6	17	5,8	27,8	5,8		
72C1 2658 11		450	26,7	400	396,6	17	5,8	37,2	5,8		
72C1 2758 11		500	29,7	450	440,6	17	5,8	45,0	5,8		

\* Kein Lagerartikel • Not a stock item

**Rohre mit UV-Schutzschicht • Pipes with UV-protection-layer**

**Beschreibung**

Die PP-RCT Druckrohre WATERTEC und STABITEC-CT sind mit einer zusätzlichen äußeren schwarzen Schutzschicht gegen UV-Einstrahlung lieferbar. Die Schutzschicht besteht aus PP-R Material und ist ausgelegt auf mitteleuropäische Verhältnisse.

**Werkstoff**

PP-RCT (Polypropylen Random-Copolymer Temperature resistant) mit modifizierter Kristallstruktur (beta nukleiert) und erhöhter Temperaturbeständigkeit, Borealis RA7050, Farbe RAL 6024 Verkehrs grün. Das Material entspricht den Anforderungen der aktuellen KTW-Leitlinie des Umweltbundesamtes (UBA). Äußere PP-R UV-Schutz-Deckschicht in schwarz.

**Geometrische Eigenschaften und Betriebsdrücke**

Siehe Ausführungen zu den aufgeführten Rohrtypen.

**Lieferung**

Bis D200 in 4 m Stangen und ab D250 in 5,8 m Stangen; abgepackt in Bunden oder Einzelverpackt. Alle Rohre/Bunde sind in schwarzer UV-Schutz-Schlauchfolie verpackt. Abgabe erfolgt nur in kompletten Verpackungseinheiten (VE's).

**Description**

The PP-RCT pressure pipes WATERTEC and STABITEC-CT are available with an additional outer black protective layer against UV irradiation. The protective layer consists of PP-R material and is designed for Central European conditions.

**Material**

PP-RCT (Polypropylene Random-Copolymer Temperature resistant) with modified crystalline structure (beta nucleated) and increased temperature resistance, colour RAL 6024 traffic green. The material complies with the requirements of the KTW guideline of the German Federal Environmental Agency (UBA). Outer PP-R UV-protection-layer in black color.

**Geometric Properties and Operating Pressure**

See explanations for the listed pipe types.

**Delivery**

Up to D200 in 4 m rods and from D250 in 5,8 m rods; packed in bundles or individual. All pipes/bundles are packed in black UV-protection-foil. Supply only in complete packing units (VE's).

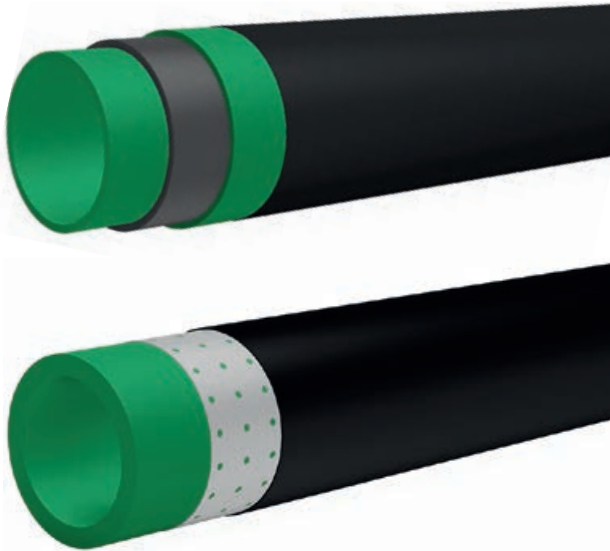

Druckrohre mit schwarzer UV-Schutzschicht  
Pressure pipes with black UV-protection-layer

D [mm]	Teil / Item	Teil / Item
	SB8215B	SB8200FW
	<b>STABITEC-CT-UV</b>	<b>WATERTEC-UV</b>
20	72S2 0640 S1	72W2 0640 S1
25	72S2 0740 S1	72W2 0740 S1
32	72S2 0840 S1	72W2 0840 S1
40	72S2 0940 S1	72W2 0940 S1
50	72S2 1040 S1	72W2 1040 S1
63	72S2 1140 S1	72W2 1140 S1
75	72S2 1240 S1	72W2 1240 S1
90	72S2 1340 S1	72W2 1340 S1
110	72S2 1440 S1	72W2 1440 S1
125	72S2 1540 S1	72W2 1540 S1
160		72W2 1740 S1

**Vorisiolierte Rohre • Preinsulated Pipes**
**Beschreibung**

Vorisiolierte Kunststoffmantelrohre zur direkten Erdverlegung. Die Herstellung erfolgt Auftragsbezogen.

**Mediumrohr**

BR Kunststoffrohre (außer STABITEC) in den Dimensionen D20 bis 500 mm.

**Mantelrohr**

Nahtlos extrudiertes PE-HD Mantelrohr, schlag- und bruchfest, zähelastisch bis -50°C, allgemeine Güteanforderungen nach DIN 8075, Maße und Wanddicke nach DIN EN 253, Corona behandelt.

**Wärmedämmung**

Aus geschäumtem Polyurethan Hartschaum, FCKW-frei, Treibmittel Cyclopentan, zwischen Mediumrohr und Schutzmantel im Verbund, Wärmeleitzahl Lambda mind. 0,026 W/mK.

Dämmstärke DS1: Standard nach DIN EN 253.

**Lieferung**

In 5,8 m Stangen. Abgabe erfolgt nur in kompletten Verpackungseinheiten (VE's).

**Description**

Pre-insulated plastic sheathing pipes for direct laying. Production is carried out by order.

**Medium pipe**

BR plastic pipes (except STABITEC) in the dimensions D20 to 500 mm.

**Casing pipe**

Seamlessly extruded PE-HD casing pipe, impact and break resistant, tough to -50°C, general quality requirements according to DIN 8075, dimensions and wall thickness according to DIN EN 253, Corona treated.

**Type**

Made of foamed polyurethane rigid foam, CFC-free, propellant cyclopentane, between medium pipe and protective sheath in the composite, heat transfer coefficient Lambda min. 0.026 W/mK.

Insulation thickness DS1: Standard according to DIN EN 253.

**Delivery**

In 5,8 m rods. Supply only in complete packing units (VE's).

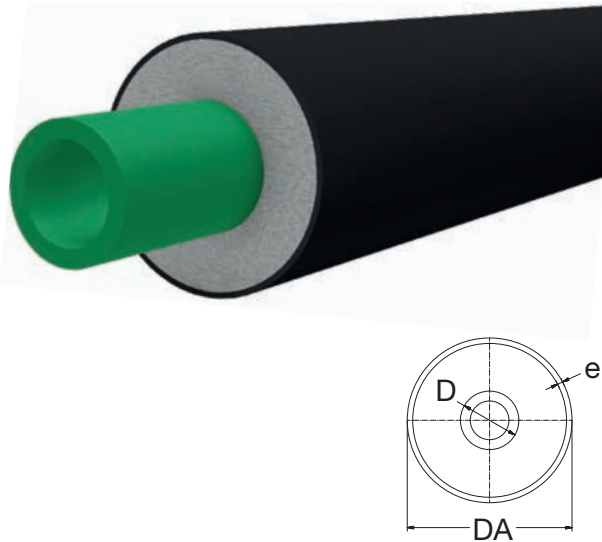
**Druckrohre vorisoliert**
**Pressure pipes preinsulated**

D [mm]	Länge [m]	DA [mm]	e [mm]	ISO [mm]
20	5,8	90	3,0	32
25	5,8	90	3,0	30
32	5,8	90	3,0	26
40	5,8	110	3,0	32
50	5,8	110	3,0	27
63	5,8	125	3,0	28
75	5,8	140	3,0	30
90	5,8	160	3,0	32
110	5,8	200	3,2	42
125	5,8	225	3,5	47
160	5,8	250	3,6	41
200	5,8	315	4,5	53
250	5,8	355	5,0	48
315	5,8	450	5,6	62
355	5,8	500	6,3	66
400	5,8	560	7,0	73
450	5,8	630	7,6	82
500	5,8	670	8,0	77

## 4.02 Formteile Muffen-Schweißen • Fittings socket-welding

### Beschreibung

Gespitzte Formteile, für die Heizelement-Muffen-Schweißung, ohne Verschwächungsbeiwerte.

### Werkstoff

PP-RCT (Polypropylen Random-Copolymer Temperature resistant) mit modifizierter Kristallstruktur (beta nukleiert) und erhöhter Temperaturbeständigkeit, Borealis RA7050, Farbe RAL 6024 Verkehrsgrün.

Das Material entspricht den Anforderungen der aktuellen KTW-Leitlinie des Umweltbundesamtes (UBA).

### Geometrische Eigenschaften

Durchmesser und Wanddicke der Muffen entsprechend DIN EN ISO 15874. Toleranzen bei den Z-Maßangaben sind abhängig von der Dimension. Bis d/D 160 = +/- 3 mm. Ab d/D 180 = +/- 10 mm.

### Betriebsdruck

Der Betriebsdruck richtet sich üblicherweise nach dem eingesetzten Rohr. Grundsätzlich sind alle Standard-Formteile für die angebotenen Rohre geeignet.

### Ausführung

Geeignet für Heizelement-Muffen-Schweißung nach DVS Richtlinie 2207. Schweiß-Geräte und Schweiß-Werkzeuge sollten der DVS Richtlinie 2208 entsprechen.

### Zertifizierung

B-R Formteile unterliegen regelmäßigen internen und externen Qualitätskontrollen. Die Formteile erfüllen die Anforderungen der DIN Certco Richtlinie ZP 10.25.1 und NSF14 + 61.

### Lieferung

Abgabe erfolgt nur in kompletten Verpackungseinheiten (VEs).

### Description

Injection moulded fittings, for socket-welding and without pressure reduction factors.

### Material

PP-RCT (Polypropylene Random-Copolymer Temperature resistant) with modified crystalline structure (beta nucleated) and increased temperature resistance, colour RAL 6024 traffic green.

The material complies with the requirements of the KTW guideline of the German Federal Environmental Agency (UBA).

### Geometric Properties

Diameter and wall thickness of sockets according DIN EN ISO 15874. Tolerances of z-sizes depends on the dimension. Up to d/D 160 = +/- 3 mm and from d/D 180 = +/- 10 mm.

### Operating pressure

The operating pressure usually depends on the used pipe. Basically, all standard fittings are suitable for the offered pipes.

### Type

Suitable for socket-welding according to DVS technical code 2207. Welding equipment according to DVS technical code 2208.

### Certification

B-R fittings succumb frequent internal and external quality controls. The fittings fulfill the requirements of the DIN Certco guideline ZP 10.25.1 and NSF14 + 61.

### Delivery

Supply only in complete packing units (VEs).

## 4.02.01 Bögen + Winkel • Bends + Elbows

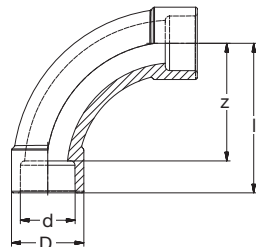

G 8002aB PP-RCT Bogen 90° grün  
PP-RCT Bend 90° green

Teil / Item	d [mm]	D [mm]	l [mm]	z [mm]	KG	VE1	VE2
7421 0690 11	20	28	56	42	0,029	10	60
7421 0790 11	25	34	69	53	0,051	10	40
7421 0890 11	32	42	86	68	0,086	5	40
7421 0990 11	40	52	106	86	0,157	5	30

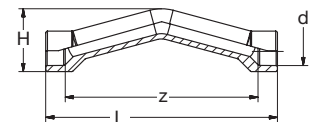

G 8287B PP-RCT Überspringbogen Muffe grün  
PP-RCT Crossover socket green

Teil / Item	d [mm]	H [mm]	L [mm]	z [mm]	KG	VE1	VE2
7461 0600 11	20	45	160	131	0,04	1	60
7461 0700 11	25	55	200	168	0,07	1	30
7461 0800 11	32	70	240	204	0,13	1	40

## 4.02.01 Bögen + Winkel • Bends + Elbows

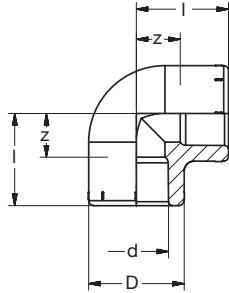

G 8090B PP-RCT Winkel 90° grün  
PP-RCT Elbow 90° green

Teil / Item	d [mm]	D [mm]	l [mm]	z [mm]	KG	VE1	VE2
7411 0690 11	20	29	28	13	0,019	10	120
7411 0790 11	25	34	32	16	0,025	10	80
7411 0890 11	32	43	38	20	0,047	10	80
7411 0990 11	40	52	44	23	0,073	5	50
7411 1090 11	50	65	52	28	0,136	10	60
7411 1190 11	63	84	62	34	0,266	4	32
7411 1290 11	75	101	71	41	0,443	2	18
7411 1390 11	90	120	83	50	0,793	2	12
7411 1490 11	110	148	99	62	1,299	1	3
7411 1590 11	125	165	124	84	2,056	1	4

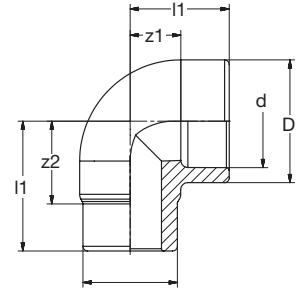

G 8092B PP-RCT Winkel 90° i-a grün  
PP-RCT Elbow 90° f-m green

Teil / Item	d [mm]	D [mm]	l1 [mm]	l2 [mm]	z1 [mm]	z2 [mm]	KG	VE1	VE2
7412 0690 11	20	29	27	36	12	21,5	0,018	10	140
7412 0790 11	25	34	30	41	14	25	0,026	10	80
7412 0890 11	32	43	36	48	18	30	0,048	10	50
7412 0990 11	40	52	42	55	21	34,5	0,075	5	30

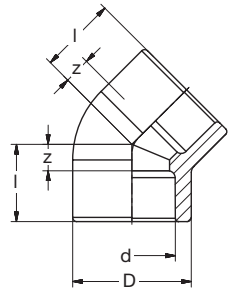

G 8041B PP-RCT Winkel 45° grün  
PP-RCT Elbow 45° green

Teil / Item	d [mm]	D [mm]	l [mm]	z [mm]	KG	VE1	VE2
7411 0645 11	20	29	21	6	0,014	10	150
7411 0745 11	25	34	24	8	0,019	10	90
7411 0845 11	32	43	28	10	0,034	10	50
7411 0945 11	40	52	32	11	0,056	5	30
7411 1045 11	50	65	37	13	0,101	5	45
7411 1145 11	63	82	44	16	0,207	2	40
7411 1245 11	75	99	50	20	0,321	2	24
7411 1345 11	90	120	58	25	0,580	2	10
7411 1445 11	110	148	69	32	0,979	2	4
7411 1545 11	125	165	77	37	1,37	1	6

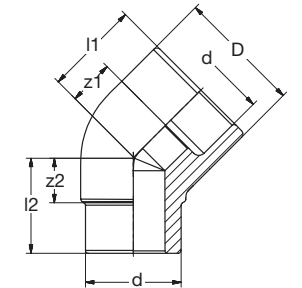

G 8040B PP-RCT Winkel 45° i-a grün  
PP-RCT Elbow 45° f-m green

Teil / Item	d [mm]	D [mm]	l1 [mm]	l2 [mm]	z1 [mm]	z2 [mm]	KG	VE1	VE2
7412 0645 11	20	29	20	28	5	28	0,013	10	120
7412 0745 11	25	34	22	34	5	34	0,023	10	80
7412 0845 11	32	43	26	39	8	39	0,041	5	50

## 4.02.02 T-Stücke + Abzweige • Tee's + Branches

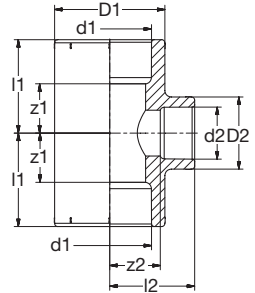
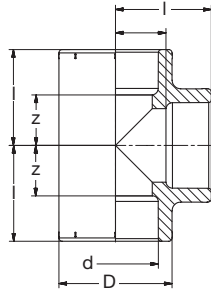

G 8130B PP-RCT T-Stück 90° grün  
PP-RCT Tee 90° green

Teil / Item	d [mm]	D [mm]	l [mm]	z [mm]	KG	VE1	VE2
7511 0690 11	20	29	28	13	0,023	10	80
7511 0790 11	25	34	32	16	0,034	10	50
7511 0890 11	32	43	38	20	0,060	5	70
7511 0990 11	40	52	44	23	0,090	5	40
7511 1090 11	50	65	52	28	0,17	10	50
7511 1190 11	63	84	62	34	0,34	2	8
7511 1290 11	75	100	71	41	0,54	2	16
7511 1390 11	90	120	83	50	0,95	2	12
7511 1490 11	110	148	99	62	1,56	1	2
7511 1590 11	125	165	124	84	2,51	1	4

G 8130B red PP-RCT T-Stück 90° red grün  
PP-RCT Tee 90° red green

Teil / Item	d1 - d2 [mm]	D1 [mm]	D2 [mm]	l1 [mm]	l2 [mm]	z1 [mm]	z2 [mm]	KG	VE1	VE2
7521 0706 11	25-20	34	29	32	32	16	17	0,035	10	60
7521 0806 11	32-20	43	29	38	36	20	21	0,060	10	30
7521 0807 11	32-25	43	34	38	36	20	22	0,060	10	30
7521 0906 11	40-20	52	43	44	39	24	24	0,083	5	40
7521 0907 11	40-25	52	43	44	40	23	24	0,086	5	40
7521 0908 11	40-32	52	43	44	40	23	22	0,091	5	40
7521 1006 11	50-20	65	43	52	46	28	31	0,16	10	50
7521 1007 11	50-25	65	43	52	46	28	30	0,16	10	50
7521 1008 11	50-32	65	43	52	46	28	28	0,16	10	50
7521 1009 11	50-40	85	85	62	62	39	35	0,16	10	50
7521 1106 11	63-20	85	43	62	62	35	48	0,31	2	8
7521 1107 11	63-25	85	43	62	62	35	46	0,31	2	8
7521 1108 11	63-32	85	43	62	62	35	44	0,31	2	8
7521 1109 11	63-40	85	85	62	62	35	42	0,32	2	8
7521 1110 11	63-50	85	85	62	62	35	39	0,32	2	8
7521 1206 11	75-20	100	43	71	71	41	57	0,50	2	16
7521 1207 11	75-25	100	43	71	71	41	55	0,50	2	16
7521 1208 11	75-32	100	43	71	71	41	53	0,50	2	16
7521 1209 11	75-40	100	65	71	71	41	51	0,50	2	16
7521 1210 11	75-50	100	65	71	71	41	48	0,51	2	16
7521 1211 11	75-63	100	101	71	71	41	44	0,52	2	16
7521 1311 11	90-63	85	83	83	50	50	53	0,91	2	12
7521 1312 11	90-75	120	100	83	83	50	53	0,91	2	12
7521 1411 11	110-63	148	85	99	99	62	71	1,53	1	3
7521 1412 11	110-75	148	100	99	99	62	69	1,54	1	3
7521 1413 11	110-90	148	120	99	99	62	66	1,57	1	3
7521 1512 11	125-75	165	100	124	104	84	74	2,30	1	4
7521 1513 11	125-90	165	120	124	106	84	73	2,28	1	4
7521 1514 11	125-110	165	148	124	110	84	87	2,36	1	4
7521 0607 11	20-25	34	34	32	32	18	16	0,04	10	60

G 8130B red PP-RCT T-Stück 90° multi-red grün  
PP-RCT Tee 90° multi-red green

Teil / Item	d1-d2-d3 [mm]	D1 [mm]	D2 [mm]	l1 [mm]	l2 [mm]	z1 [mm]	z2 [mm]	KG	VE1	VE2
7521 07BB 11	25-20-20	34	34	32	32	16	18	0,038	10	60
7521 07CB 11	25-25-20	34	34	32	32	16	16	0,038	10	60
7521 08BB 11	32-20-20	43	34	37	38	18	22	0,078	5	30
7521 08BC 11	32-20-25	43	34	37	38	18	23	0,078	5	30
7521 08CC 11	32-25-25	43	34	37	38	18	22	0,078	5	30
7521 11EF 11	63-40-50	85	85	62	62	39	35	0,37	2	8

## 4.02.02 T-Stücke + Abzweige • Tee's + Branches

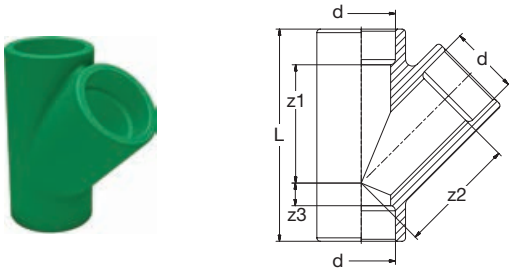

G 8165B PP-RCT Abzweig 45° **SDR11** grün  
PP-RCT Branch 45° **SDR11** green

Teil / Item	d [mm]	L [mm]	z1 [mm]	z2 [mm]	z3 [mm]	KG	VE1	VE2
7511 0845 11	32	89	40	41	11	0,062	10	50
7511 0945 11	40	122	65	64	16	0,15	10	30
7511 1045 11	50	131	67	67	18	0,23	5	20
7511 1145 11	63	169	91	89	23	0,50	2	20

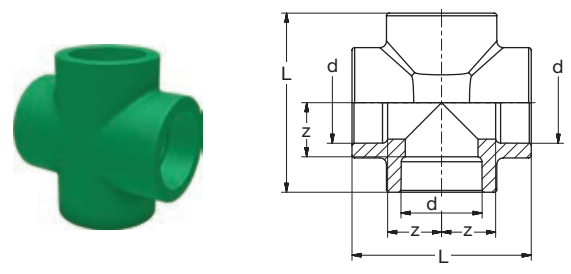

G 8180B PP-RCT Kreuzstück **SDR11** grün  
PP-RCT Cross **SDR11** green

Teil / Item	d [mm]	L [mm]	z [mm]	KG	VE1	VE2
7551 0600 11	20	52	23	0,022	10	80
7551 0700 11	25	59	27	0,037	10	50
7551 0800 11	32	78	34	0,059	10	50
7551 0900 11	40	94	42	0,11	10	80
7551 1000 11	50	112	66	0,20	10	30
7551 1100 11	63	138	84	0,35	5	20

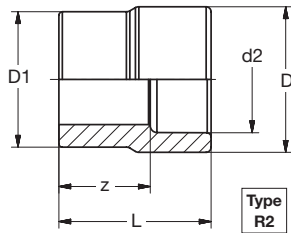
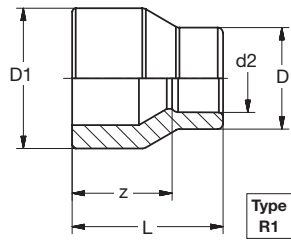

G 8243B

PP-RCT Reduktion grün  
PP-RCT Reducer green

Teil / Item	D1 - d2 [mm]	Type		D2 [mm]	L [mm]	z [mm]	KG	VE1	VE2
		R1	R2						
7321 0706 11	25-20	•		29	36	22	0,012	10	100
7321 0806 11	32-20	•		29	37	23	0,015	10	80
7321 0807 11	32-25	•		34	39	23	0,017	10	70
7321 0906 11	40-20	•		34	43	28	0,023	10	50
7321 0907 11	40-25	•		34	43	27	0,023	10	50
7321 0908 11	40-32	•		43	45	27	0,029	10	80
7321 1006 11	50-20	•		43	51	36	0,043	10	50
7321 1007 11	50-25	•		43	51	35	0,043	10	50
7321 1008 11	50-32	•		43	51	33	0,045	10	50
7321 1009 11	50-40	•		52	53	33	0,055	10	70
7321 1106 11	63-20	•		34	56	42	0,079	5	60
7321 1107 11	63-25	•		34	56	40	0,076	5	60
7321 1108 11	63-32	•		43	58	40	0,076	5	60
7321 1109 11	63-40	•		52	60	40	0,084	5	45
7321 1110 11	63-50	•		65	63	40	0,091	5	40
7321 1210 11	75-50	•		65	67	44	0,12	2	16
7321 1211 11	75-63	•		80	71	44	0,15	2	16
7321 1310 11	90-50	•		65	74	51	0,15	1	12
7321 1311 11	90-63	•		80	78	51	0,17	2	12
7321 1312 11	90-75	•		99	81	51	0,23	2	12
7321 1411 11	110-63	•		85	87	60	0,32	2	14
7321 1412 11	110-75	•		100	90	60	0,37	2	14
7321 1413 11	110-90	•		120	93	61	0,45	2	14

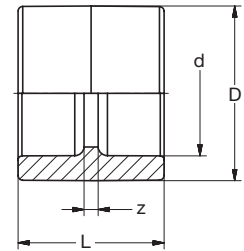

G 8270B PP-RCT Muffe grün  
PP-RCT Socket green

Teil / Item	d [mm]	D [mm]	L [mm]	z [mm]	KG	VE1	VE2
7311 0600 11	20	29	34	5	0,010	10	150
7311 0700 11	25	34	37	5	0,015	10	120
7311 0800 11	32	43	41	5	0,026	10	60
7311 0900 11	40	52	46	5	0,047	10	80
7311 1000 11	50	65	52	5	0,070	5	60
7311 1100 11	63	84	60	5	0,13	4	84
7311 1200 11	75	99	65	5	0,20	2	40
7311 1300 11	90	120	76	10	0,35	2	16
7311 1400 11	110	148	80	6	0,57	2	18
7311 1500 11	125	165	90	10	0,76	2	6

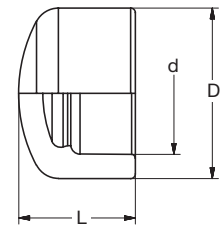

G 8301B PP-RCT Kappe grün  
PP-RCT Cap green

Teil / Item	d [mm]	D [mm]	L [mm]	KG	VE1	VE2
7341 0600 11	20	29	25	0,009	10	200
7341 0700 11	25	34	28	0,013	10	100
7341 0800 11	32	43	32	0,021	10	120
7341 0900 11	40	52	36	0,033	10	60
7341 1000 11	50	65	41	0,057	10	80
7341 1100 11	63	79	48	0,090	5	60
7341 1200 11	75	99	54	0,18	2	20
7341 1300 11	90	120	66	0,35	2	8
7341 1400 11	110	148	79	0,59	1	8
7341 1500 11	125	165	87	0,76	1	6

## 4.02.04 Übergänge • Transitions

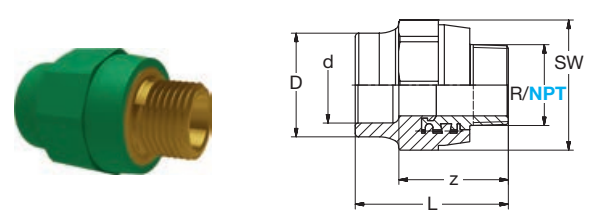
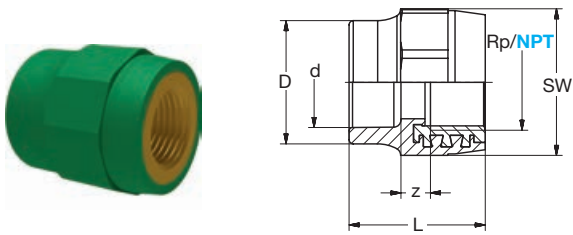

G 8270gB PP-RCT-RG Übergang **IG-zyl** grün  
PP-RCT-Bronze Transition **female-thread-cyl** green

Teil / Item	d x Rp [mm x Inch]	D [mm]	L [mm]	z [mm]	SW [mm]	KG	VE1	VE2
7R11 0643 11	20 x 1/2	30	40	11	36	0,057	10	-
7R11 0645 11	20 x 3/4	29	40	11	44	0,077	10	-
7R11 0743 11	25 x 1/2	34	41	11	36	0,057	10	-
7R11 0745 11	25 x 3/4	34	41	11	44	0,077	10	-
7R11 0845 11	32 x 3/4	43	45	11	44	0,081	10	-
7R11 0846 11	32 x 1	43	48	12	51	0,13	10	-
7R11 0946 11	40 x 1	55	54	14	63	0,18	10	-
7R11 0947 11	40 x 1 1/4	55	54	13	63	0,20	10	-
7R11 1047 11	50 x 1 1/4	64	58	12	70	0,23	10	-
7R11 1048 11	50 x 1 1/2	64	58	14	70	0,21	10	-
7R11 1150 11	63 x 2	79	69	19	85	0,42	5	-
7R11 1253 11	75 x 2 1/2	99	82	22	112	0,83	5	-
7R11 1355 11	90 x 3	118	102	39	135	1,46	2	-
7R11 1457 11	110 x 4	146	121	42	170	2,13	2	-
7R11 1558 11	125 x 5	168	125	41	208	3,51	1	-

G 8243gB PP-RCT-RG Übergang **AG-keg** grün  
PP-RCT-Bronze Transition **male-thread-con** green

Teil / Item	d x R [mm x Inch]	D [mm]	L [mm]	z [mm]	SW [mm]	KG	VE1	VE2
7R11 0673 11	20 x 1/2	29	53	40	36	0,073	10	-
7R11 0675 11	20 x 3/4	34	58	42	44	0,092	10	-
7R11 0773 11	25 x 1/2	34	56	40	36	0,073	10	-
7R11 0775 11	25 x 3/4	34	58	42	44	0,092	10	-
7R11 0875 11	32 x 3/4	43	58	42	44	0,097	10	-
7R11 0876 11	32 x 1	43	66	48	51	0,164	10	-
7R11 0976 11	40 x 1	55	71	51	62	0,21	10	-
7R11 0977 11	40 x 1 1/4	52	74	53	63	0,30	10	-
7R11 1077 11	50 x 1 1/4	64	77	54	70	0,32	10	-
7R11 1078 11	50 x 1 1/2	64	77	54	70	0,35	10	-
7R11 1180 11	63 x 2	79	92	65	85	0,55	5	-
7R11 1283 11	75 x 2 1/2	99	112	82	112	1,20	5	-
7R11 1385 11	90 x 3	120	143	111	135	1,97	2	-
7R11 1487 11	110 x 4	148	161	124	170	2,89	2	-
7R11 1588 11	125 x 5	168	170	130	208	4,38	1	-

NP 8270gB PP-RCT-EcoB Übergang **IG-NPT** grün  
PP-RCT-EcoB Transition **female-thread-NPT** green

Teil / Item	d x Rp/NPT [mm x Inch]	D [mm]	L [mm]	z [mm]	SW [mm]	KG	VE1	VE2
7L11 0643 U1	20 x 1/2	35	40	11	36	0,057	10	-
7L11 0645 U1	20 x 3/4	43	42	11	44	0,077	10	-
7L11 0745 U1	25 x 3/4	43	42	11	44	0,077	10	-
7L11 0846 U1	32 x 1	50	48	12	51	0,13	10	-
7L11 0947 U1	40 x 1 1/4	62	54	13	63	0,20	10	-
7L11 1048 U1	50 x 1 1/2	69	57	14	70	0,21	10	-
7L11 1150 U1	63 x 2	84	68	19	85	0,42	5	-
7L11 1253 U1	75 x 2 1/2	112	82	22	115	0,83	1	-

NP 8243gB PP-RCT-EcoB Übergang **AG-NPT** grün  
PP-RCT-EcoB Transition **male-thread-NPT** green

Teil / Item	d x R/NPT [mm x Inch]	D [mm]	L [mm]	z [mm]	SW [mm]	KG	VE1	VE2
7L11 0673 U1	20 x 1/2	35	55	40	36	0,073	10	-
7L11 0675 U1	20 x 3/4	43	58	42	44	0,092	10	-
7L11 0775 U1	25 x 3/4	43	58	42	44	0,092	10	-
7L11 0876 U1	32 x 1	50	66	48	51	0,164	10	-
7L11 0977 U1	40 x 1 1/4	62	74	53	63	0,30	10	-
7L11 1078 U1	50 x 1 1/2	69	77	54	70	0,35	10	-
7L11 1180 U1	63 x 2	84	92	65	85	0,55	5	-
7L11 1283 U1	75 x 2 1/2	112	112	82	115	1,2	5	-

## 4.02.04 Übergänge • Transitions

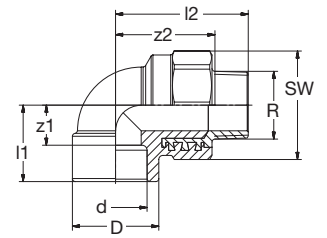
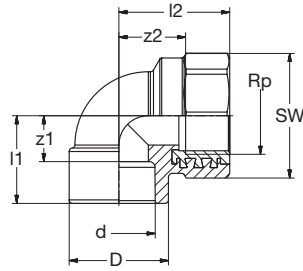

G 8090gB PP-RCT-RG Ü-Winkel 90° IG-zyl grün  
PP-RCT-Bronze Transition-Elbow 90° female-thread-cyl green

Teil / Item	d x Rp [mm x Inch]	D [mm]	l1 [mm]	l2 [mm]	z1 [mm]	z2 [mm]	SW [mm]	KG	VE1	VE2
7R21 0643 11	20 x 1/2	29	28	34	14	20	36	0,064	10	-
7R21 0645 11	20 x 3/4	34	32	40	18	25	44	0,093	10	-
7R21 0743 11	25 x 1/2	34	32	36	14	24	36	0,066	10	-
7R21 0745 11	25 x 3/4	34	32	40	16	25	44	0,091	10	-
7R21 0845 11	32 x 3/4	43	38	45	20	30	44	0,11	10	-
7R21 0846 11	32 x 1	43	38	48	20	30	51	0,15	10	-

G 8092gB PP-RCT-RG Ü-Winkel 90° AG-keg grün  
PP-RCT-Bronze Transition-Elbow 90° male-thread-con green

Teil / Item	d x R [mm x Inch]	D [mm]	l1 [mm]	l2 [mm]	z1 [mm]	z2 [mm]	SW [mm]	KG	VE1	VE2
7R21 0673 11	20 x 1/2	29	28	34	14	49	36	0,079	10	-
7R21 0675 11	20 x 3/4	34	32	40	18	56	44	0,11	10	-
7R21 0773 11	25 x 1/2	34	32	36	16	53	36	0,095	10	-
7R21 0775 11	25 x 3/4	34	32	40	16	56	44	0,11	10	-
7R21 0875 11	32 x 3/4	43	38	45	20	61	44	0,12	10	-
7R21 0876 11	32 x 1	43	38	48	20	66	51	0,18	10	-

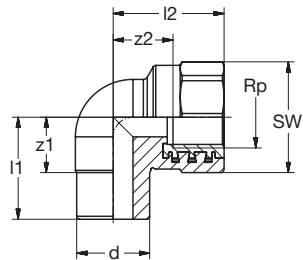

G 8091gB PP-RCT-RG Ü-Winkel 90° i IG-zyl grün  
PP-RCT-Bronze Transition-Elbow 90° fem female-thread-cyl green

Teil / Item	d x Rp [mm x Inch]	l1 [mm]	l2 [mm]	z1 [mm]	z2 [mm]	SW [mm]	KG	VE1	VE2
7R22 0643 11	20 x 1/2	34	34	19	18	36	0,06	10	-

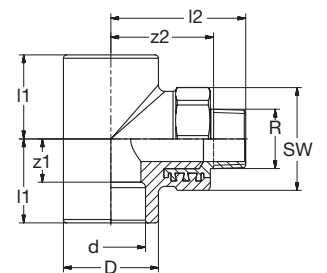
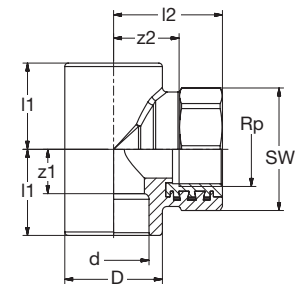

G 8130gB PP-RCT-RG Ü-T-Stück 90° IG-zyl grün  
PP-RCT-Bronze Transition-Tee 90° female-thread-cyl green

Teil / Item	d x Rp [mm x Inch]	D [mm]	l1 [mm]	l2 [mm]	z1 [mm]	z2 [mm]	SW [mm]	KG	VE1	VE2
7R41 0643 11	20 x 1/2	29	28	34	14	20	36	0,096	10	-
7R41 0645 11	20 x 3/4	34	28	35	14	20	44	0,11	10	-
7R41 0743 11	25 x 1/2	34	32	38	16	24	36	0,078	10	-
7R41 0745 11	25 x 3/4	34	32	40	16	25	44	0,10	10	-
7R41 0845 11	32 x 3/4	43	38	45	20	30	44	0,12	10	-
7R41 0846 11	32 x 1	43	38	48	20	30	51	0,17	10	-

G 8133gB PP-RCT-RG Ü-T-Stück 90° AG-keg grün  
PP-RCT-Bronze Transition-Tee 90° male-thread-con green

Teil / Item	d x R [mm x Inch]	D [mm]	l1 [mm]	l2 [mm]	z1 [mm]	z2 [mm]	SW [mm]	KG	VE1	VE2
7R41 0673 11	20 x 1/2	29	28	34	14	49	36	0,086	10	-
7R41 0675 11	20 x 3/4	29	28	35	14	50	44	0,15	10	-
7R41 0773 11	25 x 1/2	34	32	38	16	53	36	0,094	10	-
7R41 0775 11	25 x 3/4	34	32	40	16	55	44	0,12	10	-
7R41 0875 11	32 x 3/4	43	38	45	20	60	44	0,14	10	-
7R41 0876 11	32 x 1	43	38	48	20	66	51	0,21	10	-

## 4.02.05 Übergänge Wand • Transitions wall

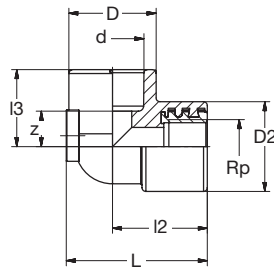
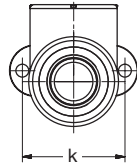

G 8472gB PP-RCT-RG Ü-Winkel 90° Wandbefestigung IG-zyl grün  
PP-RCT-Bronze Transition-Elbow 90° wall mount female-thread-cyl green

Teil / Item	d x Rp [mm x Inch]	D [mm]	D2 [mm]	L [mm]	l2 [mm]	l3 [mm]	k [mm]	z [mm]	KG	VE1	VE2
7R31 0643 11	20 x 1/2	35	29	50	35	27	40	21	0,065	10	-
7R31 0743 11	25 x 1/2	35	34	54	37	30	40	23	0,071	10	-
7R31 0745 11	25 x 3/4	43	43	65	43	35	50	28	0,12	10	-
7R31 0845 11	32 x 3/4	43	43	65	43	35	50	28	0,11	10	-

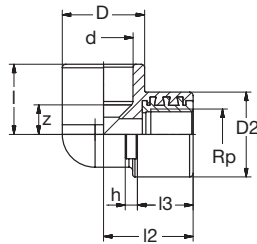
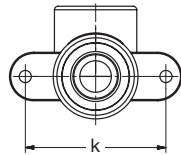

G 8473gB PP-RCT-RG Ü-Winkel 90° Hohlwandbefestigung IG-zyl grün  
PP-RCT-Bronze Transition-Elbow 90° hollow wall mount female-thread-cyl green

Teil / Item	d x Rp [mm x Inch]	D [mm]	D2 [mm]	L [mm]	l [mm]	l2 [mm]	l3 [mm]	h [mm]	k [mm]	z [mm]	KG	VE1	VE2
7R3H 0643 11	20 x 1/2	29	35	27	34	21	5	13	13	0,064	10	-	
7R3H 0743 11	25 x 1/2	34	35	30	37	23	5	14	14	0,071	10	-	

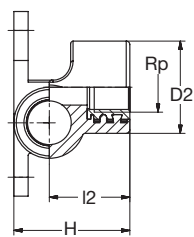
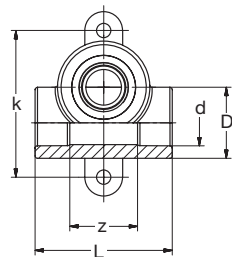

G 8490g PP-RCT-RG Ü-Winkel 90° Durchgang Wandbefestigung IG-cyl grün  
PP-RCT-Bronze Transition-Elbow 90° passage wall mount female-thread-cyl green

Teil / Item	d x Rp [mm x Inch]	D [mm]	D2 [mm]	L [mm]	l2 [mm]	H [mm]	k [mm]	z [mm]	KG	VE1	VE2
7R3D 0643 21	20 x 1/2	30	39	58	34	49	62	29	0,077	10	-

## 4.02.05 Übergänge Wand • Transitions wall

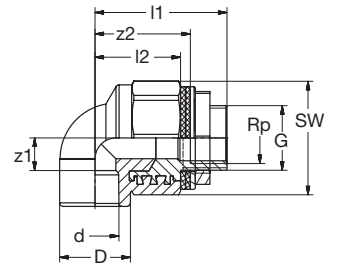
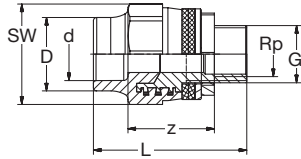

- G 8244gB PP-RCT-RG Übergang Hohlwandbefestigung IG-zyl grün  
 G 8245gB PP-RCT-Bronze Transition hollow wall mount female-thread-cyl green

- G 8093gB PP-RCT-RG Ü-Winkel 90 Hohlwandbefestigung IG-zyl grün  
 G 8095gB PP-RCT-Bronze Transition-Elbow 90 hollow wall mount male-thread-cyl green

Teil / Item	d x Rp x G [mm x Inch]	D [mm]	L [mm]	z [mm]	SW [mm]	KG	VE1	VE2
<b>Länge • Length G = 30 mm</b>								
7R1L 0645 11	20 x 1/2 x 3/4	43	70	40,5	44	0,24	10	-
<b>Länge • Length G = 19 mm</b>								
7R1H 0645 11	20 x 1/2 x 3/4	43	59	29,5	44	0,21	10	-

Komplett mit Kontersatz • complete with counter set.

Teil / Item	d x Rp x G [mm x Inch]	D [mm]	l1 [mm]	l2 [mm]	z1 [mm]	z2 [mm]	SW [mm]	KG	VE1	VE2
<b>Länge • Length G = 30 mm</b>										
7R2L 0645 11	20 x 1/2 x 3/4	29	65	35	13,5	50	44	0,25	10	-
<b>Länge • Length G = 19 mm</b>										
7R2H 0645 11	20 x 1/2 x 3/4	29	54	35	13,5	39	44	0,23	10	-

Komplett mit Kontersatz • complete with counter set.

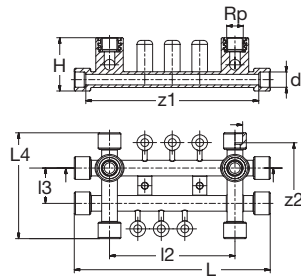

- G 8494gB PP-RCT-RG Montagegruppe 2 - Kreuz grün  
 PP-RCT-Bronze Subassembly group 2 - Cross green

Teil / Item	d x Rp [mm x Inch]	L [mm]	l2 [mm]	l3 [mm]	L4 [mm]	H [mm]	z1 [mm]	z2 [mm]	KG	VE1	VE2
7R9K 0643 11	20 x 1/2	250	160	90	135	69	221	106	0,37	1	-

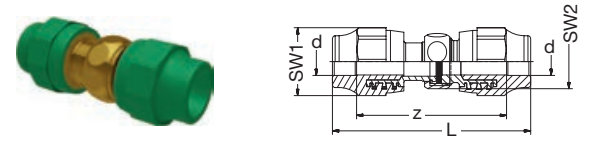
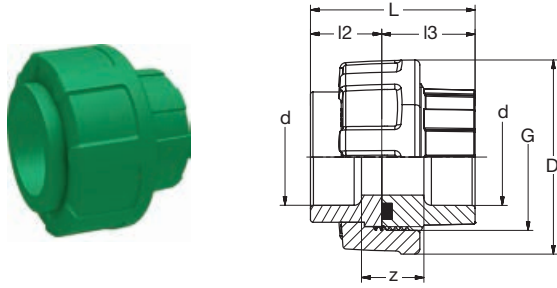

G 8330AB PP-RCT Verschraubung Runddichtring-EPDM grün  
PP-RCT Union O-Ring-gasket-EPDM green

G/EB 8330B PP-RCT-RG/**EcoB** Verschraubung Flachdichtring-EPDM grün  
PP-RCT-Bronze/**EcoB** Union flat-gasket-EPDM green

Teil / Item	d [mm]	D [mm]	G [Inch]	L [mm]	l2 [mm]	l3 [mm]	z [mm]	KG	VE1	VE2
7351 0600 31	20	46	1	44,0	17,5	26	15	0,039	1	150
7351 0700 31	25	56	1 1/4	47,5	19,0	28	15	0,061	1	125
7351 0800 31	32	66	1 1/2	51,5	21,0	30	15	0,091	1	100
7351 0900 31	40	79	2	58,0	23,5	34	17	0,14	1	60
7351 1000 31	50	87	2 1/4	66,0	26,5	39	19	0,17	1	40
7351 1100 31	63	107	2 3/4	78,5	30,5	47	23	0,28	1	30

Teil / Item	d [mm]	L [mm]	z [mm]	SW1 [mm]	SW2 [mm]	KG	VE1	VE2
<b>Rotguss • Bronze</b>								
7R51 0700 11	20	116	87	44	37	0,25	1	50
7R51 0800 11	25	119	87	44	37	0,39	1	30
7R51 0900 11	32	134	96	51	46	0,58	1	20
7R51 1000 11	40	152	110	63	52	0,98	1	12
7R51 1100 11	50	164	116	70	59	1,20	1	8
7R51 1200 11	63	189	134	85	74	2,10	1	6
7R51 1300 11	75	223	162	115	90	3,75	1	2
7R51 1400 11	90	280	213	135	95	4,21	1	1

Teil / Item	d [mm]	L [mm]	z [mm]	SW1 [mm]	SW2 [mm]	KG	VE1	VE2
<b>EcoB</b>								
7L51 0800 11	25	119	83	44	37	0,39	1	30
7L51 0900 11	32	134	96	51	46	0,58	1	20
7L51 1000 11	40	152	110	63	52	0,98	1	12
7L51 1100 11	50	163	115	70	59	1,20	1	8
7L51 1200 11	63	187	131	85	74	2,10	1	6
7L51 1300 11	75	220	160	115	90	3,75	1	2

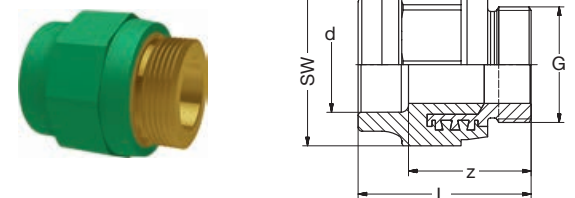
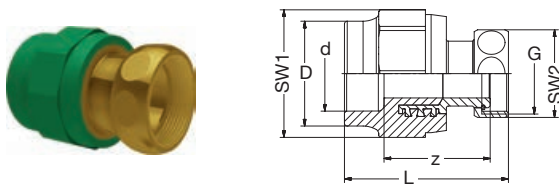

G/EB 8332B PP-RCT-RG/**EcoB** A-Verschraubung IG-zyl für Armaturen + Wasserzähler mit Flachdichtring-EPDM grün  
PP-RCT-Bronze/**EcoB** Union flat-sealing for Valves + Water meters female-thread-cyl with flat-gasket-EPDM green

G/EB 8333B PP-RCT-RG/**EcoB** Verschraubung Schraubteil flachdichtend grün  
PP-RCT-Bronze/**EcoB** Union Screw-part flat-sealing green

Teil / Item	d x G [mm x Inch]	D [mm]	L [mm]	z [mm]	SW1 [mm]	SW2 [mm]	KG	VE1	VE2
<b>Rotguss • Bronze</b>									
7R51 06A0 11	20 x 3/4	29	66	44	36	30	0,14	1	50
7R51 06A1 11	20 x 1	29	72	44	44	37	0,23	1	30
7R51 07A0 11	25 x 3/4	34	67	44	44	30	0,13	1	50
7R51 07A1 11	25 x 1	34	72	47	44	37	0,20	1	30
7R51 08A0 11	32 x 1	43	80	53	51	37	0,19	1	20
7R51 08A1 11	32 x 1 1/4	43	80	53	51	46	0,32	1	20
7R51 09A0 11	40 x 1 1/4	55	86	56	63	46	0,36	1	12
7R51 09A1 11	40 x 1 1/2	55	90	58	63	52	0,57	1	12
7R51 10A0 11	50 x 1 3/4	64	98	61	70	59	0,62	1	8
7R51 11A0 11	63 x 2 3/8	79	114	71	85	74	1,08	1	6
7R51 12A0 11	75 x 2 3/4	99	137	86	112	90	1,91	1	2
7R51 13A0 11	90 x 3 1/2	118	167	118	134	109	2,49	1	2
<b>EcoB</b>									
7L51 07A1 11	25 x 1	34	72	47	44	37	0,20	1	30
7L51 08A1 11	32 x 1 1/4	43	80	53	51	46	0,32	1	20
7L51 09A1 11	40 x 1 1/2	52	90	58	63	52	0,57	1	12
7L51 10A0 11	50 x 1 3/4	64	98	61	70	59	0,62	1	8
7L51 11A0 11	63 x 2 3/8	79	114	71	85	74	1,08	1	6
7L51 12A0 11	75 x 2 3/4	99	131	86	113	90	1,91	1	2

Teil / Item	d x G [mm x Inch]	L [mm]	z [mm]	SW [mm]	KG	VE1	VE2
<b>Rotguss • Bronze</b>							
5R51 06S0 11	20 x 3/4	50	34	36	0,11	1	50
5R51 06S1 11	20 x 1	53	38	44	0,14	1	30
5R51 07S0 11	25 x 3/4	51	35	36	0,11	1	50
5R51 07S1 11	25 x 1	54	38	44	0,14	1	30
5R51 08S1 11	32 x 1 1/4	62	43	51	0,26	1	20
5R51 09S1 11	40 x 1 1/2	72	51	63	0,45	1	12
5R51 10S0 11	50 x 1 3/4	77	53	70	0,51	1	8
5R51 11S0 11	63 x 2 3/8	88	60	85	0,75	1	6
5R51 12S0 11	75 x 2 3/4	104	74	115	1,50	1	2
5R51 13S0 11	90 x 3 1/2	132	99	135	2,33	1	2
<b>EcoB</b>							
5L51 07S1 11	25 x 1	54	38	44	0,14	1	30
5L51 08S1 11	32 x 1 1/4	62	43	51	0,26	1	20
5L51 09S1 11	40 x 1 1/2	72	51	63	0,45	1	12
5L51 10S0 11	50 x 1 3/4	77	53	70	0,51	1	8
5L51 11S0 11	63 x 2 3/8	88	60	85	0,75	1	6
5L51 12S0 11	75 x 2 3/4	104	74	115	1,50	1	2

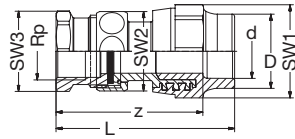

G 8332gB PP-RCT-RG Ü-Verschraubung IG-zyl Flachdichtring-EPDM grün  
 PP-RCT-Bronze Transition-Union female-thread-cyl flat-gasket-EPDM green

Teil / Item	d x Rp [mm x Inch]	G [Inch]	D [mm]	L [mm]	z [mm]	SW1 [mm]	SW2 [mm]	SW3 [mm]	KG	VE1	VE2
5R51 0643 11	20 x 1/2	3/4	29	85	70	36	30	27	0,19	1	50
5R51 0645 11	20 x 3/4	1	29	93	78	44	37	34	0,34	1	30
5R51 0743 11	25 x 1/2	3/4	34	87	71	36	30	27	0,19	1	50
5R51 0745 11	25 x 3/4	1	34	95	79	44	37	34	0,30	1	30
5R51 0845 11	32 x 3/4	1	43	97	79	44	37	34	0,34	1	20
5R51 0846 11	32 x 1	1 1/4	43	103	85	51	46	44	0,51	1	20
5R51 0947 11	13	1 1/2	52	115	94	63	52	50	0,66	1	12
5R51 1048 11	50 x 1 1/2	1 3/4	64	126	102	70	59	55	0,82	1	8
5R51 1150 11	63 x 2	2 3/8	79	142	114	85	74	70	1,30	1	3
5R51 1251 11	75 x 2 1/2	2 3/4	99	169	139	113	90	90	2,39	1	2

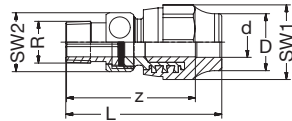

G 8333gB PP-RCT-RG Ü-Verschraubung AG-keg Flachdichtring-EPDM grün  
 PP-RCT-Bronze Transition-Union male-thread-con flat-gasket-EPDM green

Teil / Item	d x Rp [mm x Inch]	G [Inch]	D [mm]	L [mm]	z [mm]	SW1 [mm]	SW2 [mm]	KG	VE1	VE2
7R51 0673 11	20 x 1/2	3/4	29	79	65	36	30	0,18	1	50
7R51 0675 11	20 x 3/4	1	29	86	72	44	37	0,28	1	30
7R51 0773 11	25 x 1/2	3/4	34	81	65	36	30	0,16	1	50
7R51 0775 11	25 x 3/4	1	34	88	72	44	37	0,27	1	30
7R51 0875 11	32 x 3/4	1	43	81	63	44	37	0,29	1	20
7R51 0876 11	32 x 1	1 1/4	43	98	80	51	46	0,42	1	20
7R51 0977 11	40 x 1 1/4	1 1/2	52	113	92	63	52	0,59	1	12
7R51 1078 11	50 x 1 1/2	1 3/4	64	119	96	70	59	0,73	1	8
7R51 1180 11	63 x 2	2 3/8	79	137	109	85	74	1,30	1	3
7R51 1283 11	75 x 2 1/2	2 3/4	99	175	145	113	90	0,29	1	2

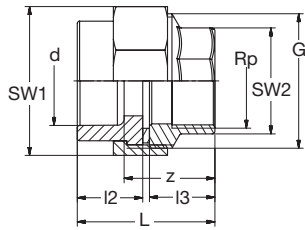
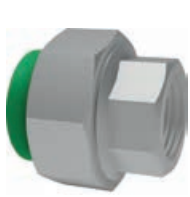

G 8542gB PP-RCT-V2A Ü-Verschraubung IG-zyl Flachdichtring-EPDM 20°C/1.0MPa grün  
 PP-RCT-Stainless steel Transition-Union female-thread-cyl flat-gasket-EPDM 20°C/1.0MPa green

Teil / Item	d x Rp [mm x Inch]	DN [mm]	G [Inch]	L [mm]	l2 [mm]	l3 [mm]	z [mm]	SW1 [mm]	SW2 [mm]	KG	VE1	VE2
7V51 0643 11	20 x 1/2	15	1	49	21	25	34	38	27	0,13	1	-
7V51 0745 11	25 x 3/4	20	1 1/4	52	21	28	36	47	32	0,22	1	-
7V51 0846 11	32 x 1	25	1 1/2	57	23	31	39	52	38	0,28	1	-
7V51 0947 11	40 x 1 1/4	32	2	62	26	33	41	66	47	0,46	1	-
7V51 1048 11	50 x 1 1/2	40	2 1/4	68	29	36	44	72	53	0,56	1	-
7V51 1150 11	63 x 2	50	2 3/4	78	33	42	50	87	65	0,93	1	-

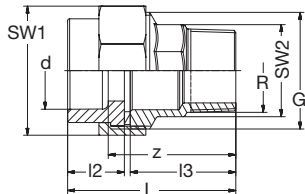

G 8547gB PP-RCT-V2A Ü-Verschraubung AG-keg Flachdichtring-EPDM 20°C/1.0MPa grün  
 PP-RCT-Stainless steel Transition-Union male-thread-con flat-gasket-EPDM 20°C/1.0MPa green

Teil / Item	d x R [mm x Inch]	DN [mm]	G [Inch]	L [mm]	l2 [mm]	l3 [mm]	z [mm]	SW1 [mm]	SW2 [mm]	KG	VE1	VE2
7V51 0673 11	20 x 1/2	15	1	68	21	43	52	38	27	0,16	1	-
7V51 0775 11	25 x 3/4	20	1 1/4	73	21	49	58	47	27	0,26	1	-
7V51 0876 11	32 x 1	25	1 1/2	79	23	53	61	52	34	0,35	1	-
7V51 0977 11	40 x 1 1/4	32	2	87	26	58	82	66	43	0,56	1	-
7V51 1078 11	50 x 1 1/2	40	2 1/4	94	29	62	89	72	50	0,71	1	-
7V51 1180 11	63 x 2	50	2 3/4	107	33	71	102	87	61	1,06	1	-

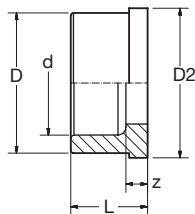

G 8060B PP-RCT Verschraubung Einlegeteil grün  
 PP-RCT Union Insert-part green

Teil / Item	d [mm]	D [mm]	D2 [mm]	L [mm]	z [mm]	KG	VE1	VE2
7351 06E0 11	20	27,5	30,0	21	6	0,006	1	-
7351 07E0 11	25	36	38,5	21	6	0,012	1	-
5351 08E0 11	32	41,5	44,7	23	6	0,014	1	-
5351 09E0 11	40	53	56,5	28	7	0,029	1	-
5351 10E0 11	50	59	62,6	32	8	0,036	1	-
5351 11E0 11	63	74	78,5	42	13	0,063	1	-
5351 12E0 11	75	90	97,2	35	5	0,081	1	-

**Flanschadapter Muffe (Bundbuchse) in gerillter Ausführung für den Einsatz von Flachdichtungen.**  
 Weitere Informationen zu Flanschen und Dichtungen finden Sie unter 6. Zubehör.

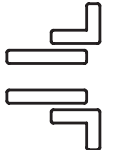

**Flange adaptor socket grooved for the use of flat gaskets.**  
 More information about flanges and gaskets see 6. Accessories.

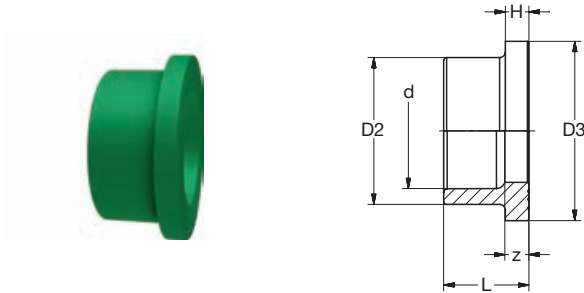

G 8790B PP-RCT Bundbuchse gerillt grün  
 PP-RCT Flange adaptor socket grooved green

Teil / Item	d [mm]	D2 [mm]	D3 [Zoll]	L [mm]	H [mm]	z [mm]	kg	VE1	VE2
7331 09F0 11	40	61	50	29	8	9	0,027	2	-
7331 10F0 11	50	74	61	27	8	4	0,043	2	-
7331 11F0 11	63	102	76	40	17	13	0,11	2	-
7331 12F0 11	75	122	90	38	19	8	0,16	2	-
7331 13F0 11	90	137	108	45	21	12	0,25	2	-
7331 14F0 11	110	158	131	50	21	13	0,30	2	-
7331 15F0 11	125	162	146	53	25	13	0,50	2	-

## Zubehör Flanschverbindung B-Buchse PP-RCT Accessories Flange Connection socket PP-RCT



Losflansch  
 Flange loose



Blindflansch  
 Flange blind



Flachdichtung mit Stahl-Einlage  
 Flat gasket with steel-inlay

d [mm]	DN [mm]	PP-St		PP-St	
		DIN/EN	ANSI	DIN/EN	ANSI
		PN10/16	150 lbs	PN10/16	150 lbs
40	32	9141 09E1 15	9141 09A2 38	9144 09E1 35	9144 09A2 38
50	40	9141 10E1 15	9141 10A2 38	9144 10E1 35	9144 10A2 38
63	50	9141 11E1 15	9151 11A2 25	9144 11E1 35	9144 11A2 38
75	65	9141 12E1 15	9141 12A2 38	9144 12E1 35	9144 12A2 38
90	80	9142 13E1 15	9141 13A2 38	9144 13E1 35	9144 13A2 38
110	100	9142 14E1 15	9152 14A2 25	9144 14E1 35	9144 14A2 38
125	100	9142 15E1 15		9144 14E1 35	

EPDM-St		NBR-St	
Wasser/Water		Gas/Gas	
PN10			
9202 09F1 35		9202 09F2 35	
9202 10F1 35		9202 10F2 35	
9202 11F1 35		9202 11F2 35	
9202 12F1 35		9202 12F2 35	
9202 13F1 35		9202 13F2 35	
9202 14F1 35		9202 14F2 35	
9202 15F1 35		9202 15F2 35	

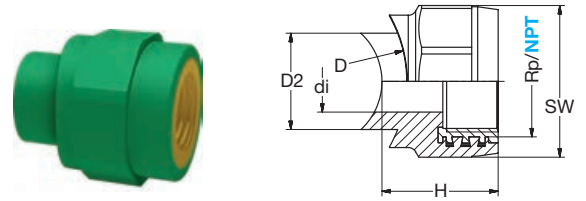
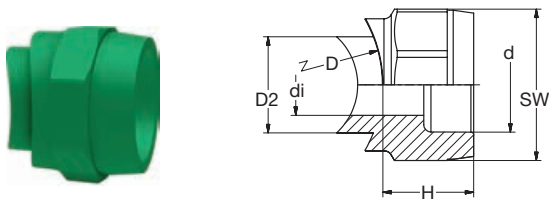

G 8130s PP-RCT Einschweißsattel Muffe grün  
PP-RCT Weld-in-saddle socket green

Teil / Item	D Rohr/Pipe x d [mm]	D2* [mm]	Di [mm]	H [mm]	SW [mm]	KG	VE1	VE2
7571 0906 11	40-50 x 20	25	15	29	38	0,024	10	120
7571 0907 11	40-50 x 25	25	15	29	38	0,021	10	120
7571 1106 11	63-125 x 20	25	15	29	38	0,025	10	120
7571 1107 11	63-125 x 25	25	15	29	38	0,022	10	120
7571 1108 11	63-125 x 32	32	20,5	35	51	0,035	10	60
7571 1209 11	75-125 x 40	40	25,5	38	63	0,083	1	30
7571 1310 11	90-125 x 50	50	32	39	70	0,098	1	24
7571 1411 11	110-125 x 63	63	40	45	85	0,163	1	18
7571 1706 11	160-250 x 20	25	15	29	38	0,027	10	120
7571 1707 11	160-250 x 25	25	15	29	38	0,024	10	120
7571 1708 11	160-250 x 32	32	20,5	35	51	0,037	10	80
7571 1709 11	160-250 x 40	40	25,5	38	63	0,082	1	30
7571 1710 11	160-250 x 50	50	32	39	70	0,097	1	24
7571 1711 11	160-250 x 63	63	40	45	85	0,162	1	18
7571 2308 11	315-630 x 32	32	20,5	35	51	0,086	10	50
7571 2309 11	315-630 x 40	40	25,5	38	63	0,093	1	30
7571 2310 11	315-630 x 50	50	32	39	70	0,097	1	24
7571 2311 11	315-630 x 63	63	40	45	85	0,161	1	18

G 8270s PP-RCT-RG Einschweißsattel IG-zyl grün  
PP-RCT-Bronze Weld-in-saddle female-thread-cyl green

Teil / Item	D Rohr/Pipe x Rp [mm x Inch]	D2* [mm]	di [mm]	H [mm]	SW [mm]	KG	VE1	VE2
7R71 0943 11	40-50 x 1/2	25	15	29	38	0,069	1	100
7R71 1143 11	63-125 x 1/2	25	15	29	38	0,07	1	100
7R71 1145 11	63-125 x 3/4	32	20,5	35	51	0,11	1	60
7R71 1246 11	75-125 x 1	40	25,5	38	63	0,17	1	-
7R71 1347 11	90-125 x 1 1/4	50	32	39	70	0,25	1	-
7R71 1348 11	90-125 x 1 1/2	50	34	39	70	0,22	1	-
7R71 1450 11	110-125 x 2	63	40	45	85	0,46	1	18
7R71 1743 11	160-250 x 1/2	25	15	29	38	0,07	10	100
7R71 1745 11	160-250 x 3/4	32	20,5	35	51	0,11	10	60
7R71 1746 11	160-250 x 1	40	25,5	38	63	0,17	1	-
7R71 1747 11	160-250 x 1 1/4	50	32	39	70	0,24	1	24
7R71 1748 11	160-250 x 1 1/2	50	34	39	70	0,24	1	24
7R71 1750 11	160-250 x 2	63	40	45	85	0,49	1	18
7R71 2345 11	315-630 x 3/4	32	20,5	35	51	0,24	1	30
7R71 2346 11	315-630 x 1	40	25,5	38	63	0,24	1	-
7R71 2347 11	315-630 x 1 1/4	50	32	39	70	0,25	1	30
7R71 2348 11	315-630 x 1 1/2	50	34	39	70	0,24	1	24
7R71 2350 11	315-630 x 2	63	40	45	85	0,48	1	18

NP 8270sB PP-RCT-EcoB Einschweißsattel IG-NPT grün  
PP-RCT-EcoB Weld-in-saddle female-thread-NPT green

Teil / Item	D Rohr/Pipe x NPT [mm x Inch]	D2* [mm]	di [mm]	H [mm]	SW [mm]	KG	VE1	VE2
7L71 0943 U1	40-50 x 1/2	25	15	29	38	0,060	1	100
7L71 1143 U1	63-125 x 1/2	25	15	29	38	0,060	1	100
7L71 1145 U1	63-125 x 3/4	32	20,5	35	51	0,105	1	60
7L71 1246 U1	75-125 x 1	40	25,5	38	63	0,138	1	-
7L71 1743 U1	160-250 x 1/2	25	15	29	38	0,062	10	100
7L71 1745 U1	160-250 x 3/4	32	20,5	35	51	0,105	10	60
7L71 1746 U1	160-250 x 1	40	25,5	38	63	0,138	1	-
7L71 2345 U1	315-630 x 3/4	32	20,5	35	51	0,105	1	30
7L71 2346 U1	315-630 x 1	40	25,5	38	63	0,135	1	-

D2 = Durchmesser Schweißstutzen / Bohrloch.  
D2 = Diameter welding stub / drill hole.

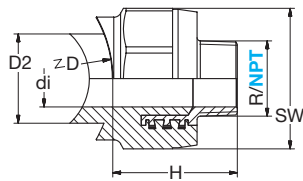

G 8243s PP-RCT-RG Einschweißsattel **AG-keg** grün  
 PP-RCT-Bronze Weld-in-saddle **male-thread-con** green

Teil / Item	D Rohr/Pipe x R [mm x Inch]	D2* [mm]	di [mm]	H [mm]	SW [mm]	KG	VE1	VE2
7R71 0973 11	40-50 x 1/2	25	15	42	38	0,088	1	80
7R71 1173 11	63-125 x 1/2	25	15	42	38	0,09	1	80
7R71 1175 11	63-125 x 3/4	32	20,5	49	51	0,13	1	50
7R71 1276 11	75-125 x 1	40	25,5	54	63	0,21	1	-
7R71 1377 11	90-125 x 1 1/4	50	32	59	70	0,34	1	-
7R71 1378 11	90-125 x 1 1/2	50	34	59	70	0,35	1	-
7R71 1480 11	110-125 x 2	63	40	68	85	0,65	1	12
7R71 1773 11	160-250 x 1/2	25	15	42	38	0,09	10	80
7R71 1775 11	160-250 x 3/4	32	20,5	49	51	0,13	10	50
7R71 1776 11	160-250 x 1	40	25,5	54	63	0,22	1	-
7R71 1777 11	160-250 x 1 1/4	50	32	59	70	0,33	1	18
7R71 1778 11	160-250 x 1 1/2	50	34	59	70	0,35	1	18
7R71 1780 11	160-250 x 2	63	40	68	85	0,73	1	12
7R71 2375 11	315-630 x 3/4	32	20,5	49	51	0,12	1	40
7R71 2376 11	315-630 x 1	40	25,5	54	63	0,24	1	-
7R71 2377 11	315-630 x 1 1/4	50	32	59	70	0,34	1	22
7R71 2378 11	315-630 x 1 1/2	50	34	59	70	0,35	1	18
7R71 2380 11	315-630 x 2	63	40	68	85	0,65	1	18

NP 8243sB PP-RCT-EcoB Einschweißsattel **AG-NPT** grün  
 PP-RCT-EcoB Weld-in-saddle **male-thread-NPT** green

Teil / Item	D Rohr/Pipe x R/NPT [mm x Inch]	D2* [mm]	di [mm]	H [mm]	SW [mm]	KG	VE1	VE2
7L71 0973 U1	40-50 x 1/2	25	15	42	38	0,075	1	80
7L71 1173 U1	63-125 x 1/2	25	15	42	38	0,073	1	80
7L71 1175 U1	63-125 x 3/4	32	20,5	49	51	0,116	1	50
7L71 1276 U1	75-125 x 1	40	25,5	54	63	0,170	1	-
7L71 1773 U1	160-250 x 1/2	25	15	42	38	0,078	10	80
7L71 1775 U1	160-250 x 3/4	32	20,5	49	51	0,116	10	50
7L71 1776 U1	160-250 x 1	40	25,5	54	63	0,171	1	-
7L71 2375 U1	315-630 x 3/4	32	20,5	49	51	0,115	1	40
7L71 2376 U1	315-630 x 1	40	25,5	54	63	0,169	1	-

D2 = Durchmesser Schweißstutzen / Bohrloch.  
 D2 = Diameter welding stub / drill hole.

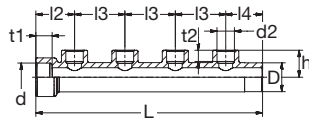

G 8240B PP-RCT Verteiler Muffen kaskadierbar grün  
PP-RCT Manifold socket cascadable green

Teil / Item	d/D - d2 x n [mm]	L [mm]	l2 [Zoll]	l3 [mm]	l4 [mm]	t1 [mm]	t2 [mm]	h [mm]	KG	VE1	VE2
7584 0806 11	32 - 20 x 4	245	43	56	37	18	14,5	30	0,13	1	20
7584 0807 11	32 - 25 x 4	250	43	56	41	18	16	35	0,15	1	30
7584 0907 11	40 - 25 x 4	248	43	56	41	20,5	16	38	0,21	1	20

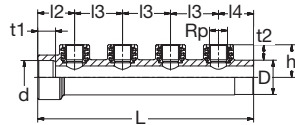

G 8240gB PP-RCT-RG Verteiler IG-zyl kaskadierbar grün  
PP-RCT-Bronze Manifold female-thread-cyl cascadable green

Teil / Item	d/D x Rp x n [mm]	L [mm]	l2 [Zoll]	l3 [mm]	l4 [mm]	t1 [mm]	t2 [mm]	h [mm]	KG	VE1	VE2
7R84 0843 11	32 x 1/2 x 4	250	43	56	41	18	14	35	0,35	1	40
7R84 0943 11	40 x 1/2 x 4	250	43	56	41	20,5	14	38	0,40	1	25
7R82 1144 11	63 x 3/4 x 2	434	148	204	82	27,5	15	59	0,74	1	15

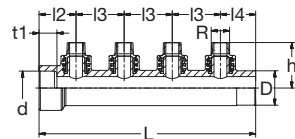

G 8241gB PP-RCT-RG Verteiler AG-keg kaskadierbar grün  
PP-RCT-Bronze Manifold male-thread-con cascadable green

Teil / Item	d/D x Rp x n [mm]	L [mm]	l2 [Zoll]	l3 [mm]	l4 [mm]	t1 [mm]	t2 [mm]	h [mm]	KG	VE1	VE2
7R84 0873 11	32 x 1/2 x 4	250	43	56	41	18	14	50	0,43	1	25
7R84 0973 11	40 x 1/2 x 4	250	43	56	41	20,5	14	53	0,47	1	20
7R82 1175 11	63 x 3/4 x 2	434	148	204	82	27,5	15	75	0,46	1	15

n = Anzahl der Abgänge • Number of outlets.

## 4.02.10 Kugelhähne • Ball valves

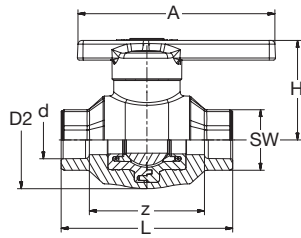

G 8850B PP-RCT Kugelhahn grün  
PP-RCT Ball valve green

Teil / Item	d [mm]	D2 [mm]	L [mm]	H [mm]	A [mm]	SW [mm]	z [mm]	KG	VE1	VE2
7911 0600 11	20	50	88	51	100	31	59,0	0,15	1	-
7911 0700 11	25	55	92	54	100	38	59,6	0,17	1	-
7911 0800 11	32	66	99	58	100	46	64,0	0,23	1	-
7911 0900 11	40	90	115	76	144	54	73,4	0,52	1	-
7911 1000 11	50	103,5	123,5	82	144	66	76,5	0,65	1	-
7911 1100 11	63	115,0	150	90	144	82	94,6	0,83	1	-

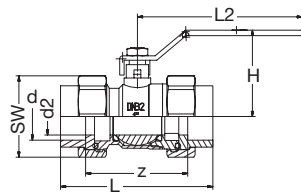

PP-RCT Kugelhahn-Ms verschraubt Runddichtring-EPDM grün  
PP-RCT Ball valve Brass with union-nuts O-Ring-gasket-EPDM green

Teil / Item	d [mm]	d2 [mm]	L [mm]	L2 [mm]	H [mm]	z [mm]	SW [mm]	KG	VE1	VE2
7MKV 0600 21	20	15	85	87	41	55	37	0,33	1	-
7MKV 0700 21	25	20	94	87	45	64	46	0,50	1	-
7MKV 0800 21	32	25	103	112	58	69	52	0,71	1	-

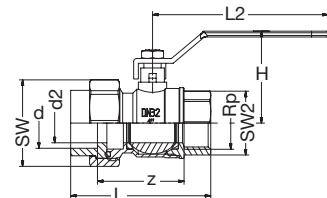

PP-RCT Ü-Kugelhahn-Ms IG-zyl verschraubt Runddichtring-EPDM grün  
PP-RCT Transition-Ball valve Brass female-thread-cyl with union-nuts O-Ring-gasket-EPDM green

Teil / Item	dx Rp [mm x Inch]	d2 [mm]	L [mm]	L2 [mm]	H [mm]	z [mm]	SW [mm]	SW2 [mm]	KG	VE1	VE2
7MKV 0643 21	20 x 1/2	15	71	87	41	42	37	26	0,23	1	-
7MKV 0745 21	25 x 3/4	20	80	87	45	50	46	32	0,39	1	-
7MKV 0846 21	32 x 1	25	89	112	58	54	52	38	0,59	1	-

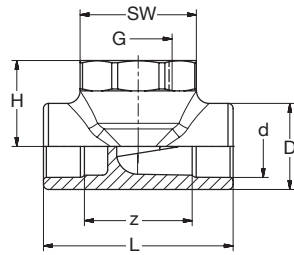

G 8599aB PP-RCT Ventil Geradsitz Unterteil IG-zyl grün  
PP-RCT Valve straight bottom part female-thread-cyl green

Teil / Item	d x G [mm]	D [mm]	L [mm]	H [mm]	z [mm]	SW [mm]	KG	VE1	VE2
7RG1 06U0 11	20 x 3/4	29	75	34	46	46	0,110	5	-
7RG1 07U0 11	25 x 3/4	34	75	34	43	46	0,117	5	-
7RG1 08U0 11	32 x 3/4	43	75	34	38	46	0,134	5	-

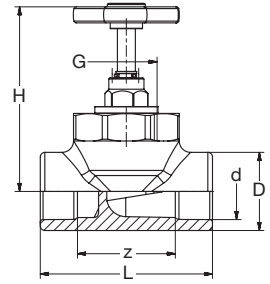

G 8599cB PP-RCT Ventil Geradsitz mit Handrad grün  
PP-RCT Valve straight with hand wheel green

Teil / Item	d x G [mm]	D [mm]	L [mm]	H [mm]	z [mm]	KG	VE1	VE2
7RG1 060H 11	20 x 3/4	34	75	69	46	0,29	1	-
7RG1 070H 11	25 x 3/4	34	75	69	43	0,29	1	-
7RG1 080H 11	32 x 3/4	43	75	69	39	0,32	1	-

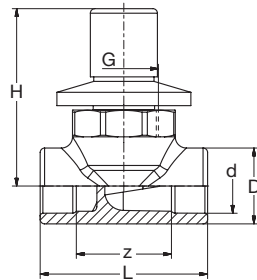

G 8599bB PP-RCT Ventil Geradsitz UP mit Drehgriff grün  
PP-RCT Valve straight concealed with handle bar green

Teil / Item	d x G [mm]	D [mm]	L [mm]	H [mm]	z [mm]	KG	VE1	VE2
7RG1 060G 11	20 x 3/4	29	75	112	46	0,330	1	-
7RG1 070G 11	25 x 3/4	34	75	112	43	0,332	1	-
7RG1 080G 11	32 x 3/4	43	75	112	38	0,320	1	-

Mit verchromter Rosette 70 mm.  
With chromed rosette 70 mm.

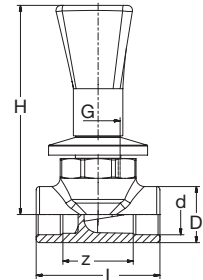

G 8599dB PP-RCT Ventil Geradsitz UP mit Flügelrad + Kappe grün  
PP-RCT Valve straight concealed with winged wheel + cap green

Teil / Item	d x G [mm]	D [mm]	L [mm]	H [mm]	z [mm]	KG	VE1	VE2
7RG1 060K 11	20 x 3/4	29	75	63	46	0,286	1	-
7RG1 070K 11	25 x 3/4	34	75	63	43	0,275	1	-
7RG1 080K 11	32 x 3/4	43	75	63	38	0,298	1	-

Mit verchromter Rosette 70 mm.  
With chromed rosette 70 mm.

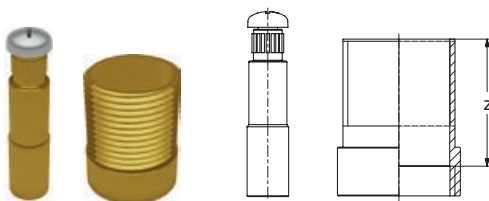

G 8599v Ventil Geradsitz UP Verlängerungsset 30mm  
Valve straight concealed prolongation-set 30mm

Teil / Item	L [mm]	KG	VE1	VE2
9902 0004 09	30	0,15	1	-

Bestehend aus: Gewindehülse, Achsverlängerung und Schraube.  
Consists of: threaded sleeve, axle extension and screw.

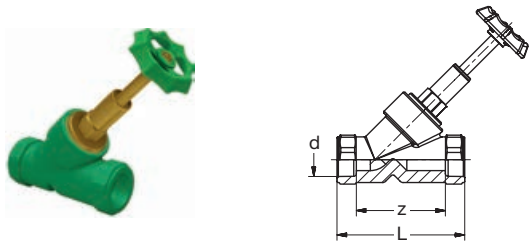

G 8700B PP-RCT-RG Ventil Schrägsitz mit Metallsitz grün  
G 8700/1B PP-RCT-Bronze Valve angle with metal seat green

Teil / Item	d [mm]	L [mm]	z [mm]	KG	VE1	VE2
7RS1 0600 11	20	115	86	0,31	1	-
7RS1 0700 11	25	115	83	0,31	1	-
7RS1 0800 11	32	120	84	0,49	1	-
7RS1 0900 11	40	145	104	0,73	1	-

**mit Rückflussverhinderer • with back-flow-preventor**

7RS1 060R 11	20	115	86	0,26	1	-
7RS1 070R 11	25	115	83	0,29	1	-
7RS1 080R 11	32	120	84	0,44	1	-
7RS1 090R 11	40	145	104	0,60	1	-

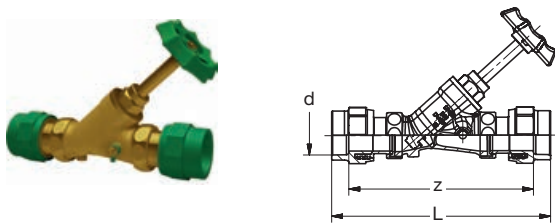

G 8600B PP-RCT-RG Ventil Schrägsitz-Ms verschraubt grün  
G 8600/1B PP-RCT-Bronze Valve angle Brass union-nuts green

Teil / Item	d [mm]	L [mm]	z [mm]	KG	VE1	VE2
-------------	--------	--------	--------	----	-----	-----

**mit Entleerung • with drainage**

7MSV 060E 11	20			0,65	1	-
7MSV 070E 11	25			0,94	1	-
7MSV 080E 11	32			1,50	1	-
7MSV 090E 11	40			2,30	1	-
7MSV 100E 11	50	298	251	2,82	1	-
7MSV 110E 11	63	347	292	4,33	1	-

**mit Rückflussverhinderer • with back-flow-preventor**

7MSV 060R 11	20			0,65	1	-
7MSV 070R 11	25			0,94	1	-
7MSV 080R 11	32			1,50	1	-
7MSV 090R 11	40			2,30	1	-
7MSV 100R 11	50	298	251	2,82	1	-
7MSV 110R 11	63	347	292	4,33	1	-

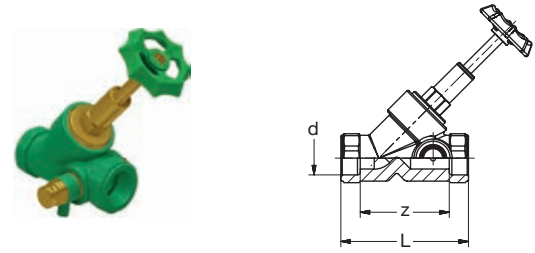

G 8800B PP-RCT-RG Ventil Schrägsitz mit Metallsitz + Entleerung + Prüfstopfen grün  
PP-RCT-Bronze Valve angle with metal seat + drainage + test-plug green

Teil / Item	d [mm]	L [mm]	z [mm]	KG	VE1	VE2
7RS1 060E 11	20	115	86	0,38	1	-
7RS1 070E 11	25	115	83	0,39	1	-
7RS1 080E 11	32	120	84	0,56	1	-
7RS1 090E 11	40	145	104	0,74	1	-

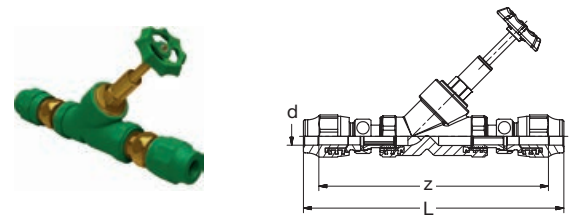

G 8655B PP-RCT-RG Ventil Schrägsitz mit Metallsitz verschraubt grün  
G 8655/1B PP-RCT-Bronze Valve angle with metal seat union-nuts green

Teil / Item	d [mm]	L [mm]	z [mm]	KG	VE1	VE2
-------------	--------	--------	--------	----	-----	-----

**mit Entleerung + Prüfstopfen • with drainage + test plug**

7RSV 0600 11	20	258	229	0,76	1	-
7RSV 0700 11	25	261	229	0,78	1	-
7RSV 0800 11	32	294	258	1,18	1	-
7RSV 0900 11	40	336	295	1,98	1	-

**mit Rückflussverhinderer • with back-flow-preventor**

7RSV 060R 11	20	258	229	0,57	1	-
7RSV 070R 11	25	261	229	0,58	1	-
7RSV 080R 11	32	294	258	1,18	1	-
7RSV 090R 11	40	336	295	1,96	1	-

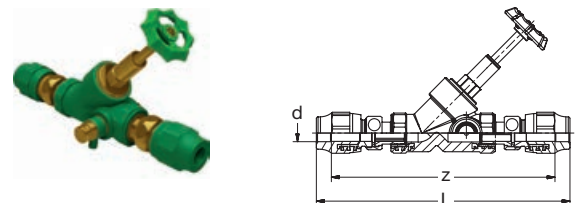

G 8650B PP-RCT-RG Ventil Schrägsitz mit Entleerung + Prüfstopfen verschraubt grün  
PP-RCT-Bronze Valve angle with drainage + test-plug and Union-nuts green

Teil / Item	d [mm]	L [mm]	z [mm]	KG	VE1	VE2
-------------	--------	--------	--------	----	-----	-----

7RSV 060E 11	20	258	229	0,53	1	-
7RSV 070E 11	25	261	229	0,77	1	-
7RSV 080E 11	32	294	258	1,09	1	-
7RSV 090E 11	40	336	295	1,94	1	-

## 4.03 Formteile Stumpf-Schweißen • Fittings butt-welding

### Beschreibung

Gespitzte Formteile, für die Heizelement-Stumpf-Schweißung und die Heizwendel-Muffen-Schweißung (nur lange Ausführung); ohne Verschwächungsbeiwerte.

### Werkstoff

PP-RCT (Polypropylen Random-Copolymer Temperature resistant) mit modifizierter Kristallstruktur (beta nukleiert) und erhöhter Temperaturbeständigkeit, Borealis RA7050, Farbe RAL 6024 Verkehrsgrün.

Das Material entspricht den Anforderungen der aktuellen KTW-Leitlinie des Umweltbundesamtes (UBA).

### Geometrische Eigenschaften

Außendurchmesser und Wanddicke entsprechend DIN EN ISO 15874.

Toleranzen bei den Z-Maßangaben sind abhängig von der Dimension. Bis d/D 160 = +/- 3 mm. Ab d/D 180 = +/- 10 mm.

### Betriebsdruck

Der Betriebsdruck richtet sich nach der SDR Klasse und dem eingesetzten Rohr.

### Ausführung

Geeignet für Heizelement-Stumpf-Schweißung und Heizwendel-Muffen-Schweißung nach DVS Richtlinie 2207. Schweiß-Geräte und Schweiß-Werkzeuge sollten der DVS Richtlinie 2208 entsprechen.

### Zertifizierung

B-R Formteile unterliegen regelmäßigen internen und externen Qualitätskontrollen. Die Formteile erfüllen die Anforderungen der DIN Certco Richtlinie ZP 10.25.1 und NSF14 + 61.

### Lieferung

Abgabe erfolgt nur in kompletten Verpackungseinheiten (VEs).

### Description

Injection moulded fittings, for butt-welding and electrofusion-socket-welding (only long type); without pressure reduction factors.

### Material

PP-RCT (Polypropylene Random-Copolymer Temperature resistant) with modified crystalline structure (beta nucleated) and increased temperature resistance, colour RAL 6024 traffic green.

The material complies with the requirements of the KTW guideline of the German Federal Environmental Agency (UBA).

### Geometric Properties

Outside Diameter and wall thickness according to DIN EN ISO 15874.

Tolerances of z-sizes depends on the dimension. Up to d/D 160 = +/- 3 mm and from d/D 180 = +/- 10 mm.

### Operating pressure

The operating pressure depends on the SDR class and the used pipe.

### Type

Suitable for butt-welding and electrofusion-socket-welding according to DVS technical code 2207. Welding equipment according to DVS technical code 2208.

### Certification

B-R fittings succumb frequent internal and external quality controls. The fittings fulfill the requirements of the DIN Certco guideline ZP 10.25.1 and NSF14 + 61.

### Delivery

Supply only in complete packing units (VEs).

## 4.03.01 Winkel • Elbows

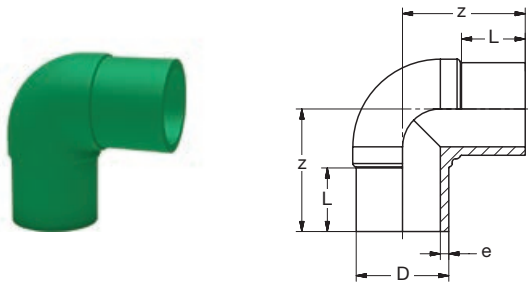

G 8090B PP-RCT Winkel 90° lang st **SDR11** grün  
PP-RCT Elbow 90° long butt **SDR11** green

Teil / Item	D [mm]	e [mm]	L [mm]	z [mm]	KG	VE1	VE2
7413 1790 11	160	14,6	117	210	3,0	1	-
7413 1990 11	200	18,2	128	250	5,4	1	-
7413 2190 11	250	22,7	180	307	9,5	1	-
7413 2390 11	315	28,6	192	393	17,7	1	-
7413 2490 11	355	32,2	170	411	28,3	1	-
7413 2590 11	400	36,3	187	470	39,6	1	-
7413 2690 11	450	40,9	204	527	57,0	1	-
7413 2790 11	500	45,4	222	562	75,6	1	-

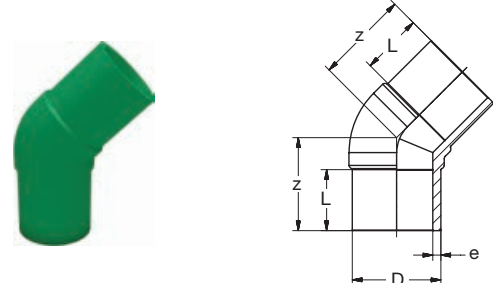

G 8041B PP-RCT Winkel 45° lang st **SDR11** grün  
PP-RCT Elbow 45° long butt **SDR11** green

Teil / Item	D [mm]	e [mm]	L [mm]	z [mm]	KG	VE1	VE2
7413 1745 11	160	14,6	113	169	2,4	1	3
7413 1945 11	200	18,2	127	201	4,4	1	-
7413 2145 11	250	22,7	155	217	8,0	1	-
7413 2345 11	315	28,6	161	280	14,9	1	-
7413 2445 11	355	32,2	170	320	21,9	1	-
7413 2545 11	400	36,3	187	350	30,1	1	-
7413 2645 11	450	40,9	204	383	41,4	1	-
7413 2745 11	500	45,4	220	410	54,9	1	-

G 80917B PP-RCT Winkel 90° lang st **SDR17** grün  
PP-RCT Elbow 90° long butt **SDR17** green

Teil / Item	D [mm]	e [mm]	L [mm]	z [mm]	KG	VE1	VE2
7414 1790 11	160	9,5	117	210	2,33	1	-
7414 1990 11	200	11,9	128	250	4,34	1	-
7414 2190 11	250	14,8	180	307	7,62	1	-

G 80417B PP-RCT Winkel 45° lang st **SDR17** grün  
PP-RCT Elbow 45° long butt **SDR17** green

Teil / Item	D [mm]	e [mm]	L [mm]	z [mm]	KG	VE1	VE2
7414 1745 11	160	9,5	113	169	1,97	1	3
7414 1945 11	200	11,9	127	201	3,62	1	-
7414 2145 11	250	14,8	155	217	6,12	1	-

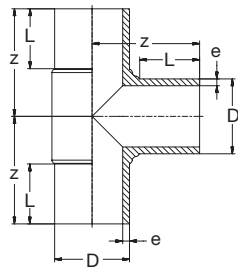

G 8130B PP-RCT T-Stück 90° lang st **SDR11** grün  
PP-RCT Tee 90° long butt **SDR11** green

Teil / Item	D [mm]	e [mm]	L [mm]	z [mm]	KG	VE1	VE2
7513 1790 11	160	14,6	124	225	4,01	1	-
7513 1990 11	200	18,2	127	251	7,30	1	-
7513 2190 11	250	22,7	148	314	13,8	1	-
7513 2390 11	315	28,6	165	357	27,6	1	-
7513 2490 11	355	32,2	170	392	34,7	1	-
7513 2590 11	400	36,3	187	435	50,0	1	-
7513 2690 11	450	40,9	204	480	70,0	1	-
7513 2790 11	500	45,4	220	523	90,0	1	-

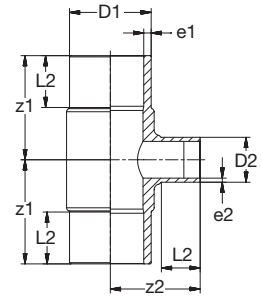

G 8130B PP-RCT T-Stück 90° red lang st **SDR11** grün  
PP-RCT Tee 90° red long butt **SDR11** green

Teil / Item	D1-D2 [mm]	e1 [mm]	e2 [mm]	L1 [mm]	L2 [mm]	z1 [mm]	z2 [mm]	KG	VE1	VE2
7523 1713 11	160-90	14,6	8,2	111	84	212	190	3,53	1	-
7523 1714 11	160-110	14,6	10,0	111	93	212	197	3,56	1	-
7523 1913 11	200-90	18,2	8,2	128	88	258	213	6,17	1	-
7523 1914 11	200-110	18,2	10,0	128	98	258	224	6,28	1	-
7523 1915 11	200-125	18,2	11,4	128	104	258	226	6,37	1	-
7523 1917 11	200-160	18,2	14,6	128	112	258	242	6,70	1	-

G 81317B PP-RCT T-Stück 90° lang st **SDR17** grün  
PP-RCT Tee 90° long butt **SDR17** green

Teil / Item	D [mm]	e [mm]	L [mm]	z [mm]	KG	VE1	VE2
7514 1790 11	160	9,5	124	225	3,84	1	-
7514 1990 11	200	11,9	127	251	6,65	1	-
7514 2190 11	250	14,8	148	314	13,4	1	-

G 81317B PP-RCT T-Stück 90° red lang st **SDR17** grün  
PP-RCT Tee 90° red long butt **SDR17** green

Teil / Item	D1-D2 [mm]	e1 [mm]	e2 [mm]	L1 [mm]	L2 [mm]	z1 [mm]	z2 [mm]	KG	VE1	VE2
7524 1713 11	160-90	9,5	5,4	111	84	212	190	2,92	1	-
7524 1913 11	200-90	11,9	5,4	128	88	258	213	5,22	1	-
7524 1914 11	200-110	11,9	6,6	128	98	258	224	5,25	1	-

### 4.03.03 Reduktionen, Kappen • Reducers, Caps

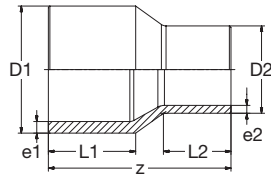

G 8243B PP-RCT Reduktion lang st **SDR7,4** grün  
PP-RCT Reducer long butt **SDR7,4** green

Teil / Item	D1-D2 [mm]	e1 [mm]	e2 [mm]	L1 [mm]	L2 [mm]	z [mm]	KG	VE1	VE2
7328 1514 11	125-110	17,1	15,1	100	85	225	1,03	1	9
7328 1917 21	200-160	27,4	21,9				4,20	1	-
7328 2119 21	250-200	34,2	27,4				6,20	1	-

G 82417B PP-RCT Reduktion lang st **SDR17** grün  
PP-RCT Reducer long butt **SDR17** green

Teil / Item	D1-D2 [mm]	e1 [mm]	e2 [mm]	L1 [mm]	L2 [mm]	z [mm]	KG	VE1	VE2
7324 1714 11	160-110	14,6	10,0	110	93	255	1,15	1	6
7324 1715 11	160-125	14,6	11,4	113	95	260	1,12	1	6
7324 1917 11	200-160	18,2	14,6	142	117	303	2,61	1	2
7324 2117 11	250-160	22,7	14,6	138	111	339	3,95	1	-
7324 2119 11	250-200	22,7	18,2	140	130	340	4,45	1	-
7324 2321 11	315-250	28,6	22,7	160	145	400	7,85	1	-

G 82417B PP-RCT Reduktion kurz st **SDR17** grün  
PP-RCT Reducer short butt **SDR17** green

Teil / Item	D1-D2 [mm]	e1 [mm]	e2 [mm]	L1 [mm]	L2 [mm]	z [mm]	KG	VE1	VE2
7326 1914 21	200-110	18,2	10,0				1,10	1	-

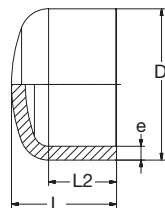

G 8301B PP-RCT Kappe lang st **SDR11** grün  
PP-RCT Cap long butt **SDR11** green

Teil / Item	D [mm]	e [mm]	L [mm]	L2 [mm]	KG	VE1	VE2
7343 1700 11	160	14,6	140	100	0,91	1	-
7343 1900 11	200	18,2	190	145	2,04	1	-
7343 2100 11	250	22,7	218	163	3,17	1	-
7343 2300 11	315	28,6	250	192	5,92	1	-
7343 2400 11	355	32,2	275	215	8,39	1	-
7343 2500 11	400	36,3	283	228	11,7	1	-
7343 2600 11	450	40,9	306	195	16,5	1	-
7343 2700 11	500	45,4	335	212	23,3	1	-

G 8243B PP-RCT Reduktion lang st **SDR11** grün  
PP-RCT Reducer long butt **SDR11** green

Teil / Item	D1-D2 [mm]	e1 [mm]	e2 [mm]	L1 [mm]	L2 [mm]	z [mm]	KG	VE1	VE2
7323 1714 11	160-110	14,6	10,0	110	93	255	1,15	1	6
7323 1715 11	160-125	14,6	11,4	113	95	260	1,12	1	6
7323 1914 21	200-110	18,2	10,0				1,10	1	-
7323 1917 11	200-160	18,2	14,6	142	117	303	2,61	1	2
7323 2117 11	250-160	22,7	14,6	138	111	339	3,95	1	-
7323 2119 11	250-200	22,7	18,2	140	130	340	4,45	1	-
7323 2321 11	315-250	28,6	22,7	160	145	400	7,85	1	-
7323 2421 11	355-250	32,2	22,7	177	150	425	10,1	1	-
7323 2423 11	355-315	32,2	28,6	177	173	425	11,9	1	-
7323 2523 11	400-315	36,3	28,6	190	165	460	14,8	1	-
7323 2524 11	400-355	36,3	32,2	190	185	463	16,2	1	-
7323 2623 11	450-315	40,9	28,6				18,9	1	-
7323 2624 11	450-355	40,9	32,2				20,5	1	-
7323 2625 11	450-400	40,9	36,3				22,3	1	-
7323 2724 11	500-355	45,4	32,2				26,2	1	-
7323 2725 11	500-400	45,4	36,3				28,1	1	-
7223 2712 11	500-450	45,4	40,9				29,9	1	-

G 8243B PP-RCT Reduktion kurz st **SDR11** grün  
PP-RCT Reducer short butt **SDR11** green

Teil / Item	D1-D2 [mm]	e1 [mm]	e2 [mm]	L1 [mm]	L2 [mm]	z [mm]	KG	VE1	VE2
7325 2319 21	315-200	28,6	18,2				2,80	1	-
7325 2415 21	355-125	32,2	11,4				6,50	1	-
7325 2417 21	355-160	32,2	14,6				6,50	1	-
7325 2519 21	400-200	36,3	18,2				1	-	-
7325 2521 21	400-250	36,3	22,7				7,00	1	-
7325 2619 21	450-200	40,9	18,2				7,80	1	-
7325 2621 21	450-250	40,9	22,7				7,00	1	-
7325 2719 21	500-200	45,4	18,2				10,0	1	-
7325 2721 21	500-250	45,4	22,7				10,0	1	-
7325 2723 21	500-315	45,4	28,6				18,2	1	-

## 4.03.04 Flanschverbindung • Flange connection

### Vorschweißbund (V-Bund) in gerillter Ausführung für den Einsatz von Flachdichtungen.

Weitere Informationen zu Flanschen und Dichtungen finden Sie unter 6. Zubehör.

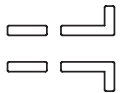

### Flange adaptor spigot grooved for the use of flat gaskets.

More information about flanges and gaskets see 6. Accessories.

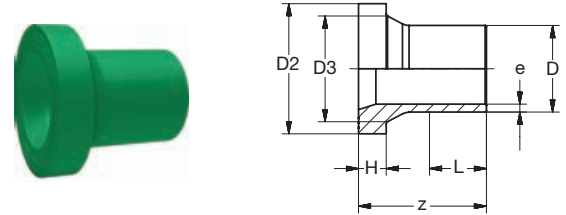
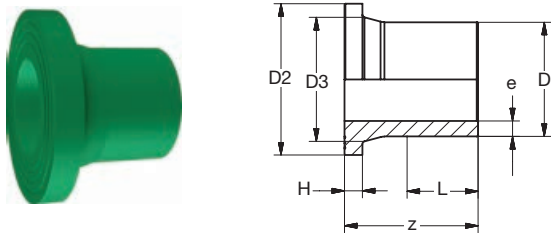

G 8791B PP-RCT V-Bund gerillt lang st **SDR11** grün  
PP-RCT Flange adaptor spigot grooved long butt **SDR11** green

Teil / Item	D [mm]	e [mm]	D2 [mm]	D3 [mm]	H [mm]	L [mm]	z [mm]	KG	VE1	VE2
7333 17F0 11	160	14,6	212	175	25	110	175	1,57	1	-
7333 19F0 11	200	18,2	268	232	32	127	205	3,90	1	-
7333 21F0 11	250	22,7	320	285	35	146	235	5,02	1	-
7333 23F0 11	315	28,6	372	337	36	185	262	7,40	1	-
7333 24F0 11	355	32,2	430	373	40	182	280	10,6	1	-
7333 25F0 11	400	36,3	482	427	45	192	315	15,2	1	-
7333 26F0 11	450	40,9	585	514	60	220	340	24,4	1	-
7333 27F0 11	500	45,4	585	530	60	234	344	36,0	1	-

G 8792B PP-RCT V-Bund Klappe gerillt lang st **SDR6** grün  
PP-RCT Flange adaptor valve spigot grooved long butt **SDR6** green

Teil / Item	D [mm]	e [mm]	D2 [mm]	D3 [mm]	H [mm]	L [mm]	z [mm]	KG	VE1	VE2
7337 14FK 11	110	18,3	158	125	32,0	100	170	1,00	1	-
7337 15FK 11	125*	20,8	188	155	40	104	185	1,35	1	-

\* Klappe und Zubehör = D140  
Valve and Accessories = D140

G 87917B PP-RCT V-Bund gerillt lang st **SDR17** grün  
PP-RCT Flange adaptor spigot grooved long butt **SDR17** green

Teil / Item	D [mm]	e [mm]	D2 [mm]	D3 [mm]	H [mm]	L [mm]	z [mm]	KG	VE1	VE2
7334 17F0 11	160	9,5	212	175	25	110	175	1,49	1	-
7334 19F0 11	200	11,9	268	232	32	127	205	2,90	1	-
7334 21F0 11	250	14,8	320	285	35	146	235	4,74	1	-
7334 23F0 11	315	18,7	372	337	36	185	262	7,40	1	-

**Zubehör Flanschverbindung V-Bund PP-RCT  
Accessories Flange Connection spigot PP-RCT**

 Losflansch  
Flange loose

D [mm]	DN [mm]	PP-St			PP-GGG	PP-St
		DIN/EN			ANSI	
		PN10/16	PN10	PN16	150 lbs	
110	100	9143 14E1 15			9153 14A2 25	9143 14A2 38
140	125	9143 16E1 15				
160	150	9143 17E1 15				
200	200		9143 19E2 15	9143 19E3 35	9153 17A2 25	9143 17A2 38
250	250		9143 21E2 15	9143 21E3 35	9153 19A2 25	9143 19A2 38
315	300		9143 23E2 15	9143 23E3 35	9153 21A2 25	9143 21A2 38
355	350		9143 24E2 15	9143 24E3 35	9153 23A2 25	9143 23A2 38
400	400		9143 25E2 15	9143 25E3 35		9143 24A2 38
450	450		9143 26E2 35			
500	500		9143 27E2 35			9143 25A2 38
						9143 27A2 38

 Blindflansch  
Flange blind

D [mm]	DN [mm]	PP-St		
		DIN/EN		ANSI
		PN10/16	PN10	150 lbs
110	100	9144 14E1 35		9144 14A2 38
140	125	9144 16E1 35		
160	150	9144 17E1 35		9144 17A2 38
200	200		9144 19E2 35	9144 19A2 38
250	250		9144 21E2 35	9144 21A2 38
315	300		9144 23E2 35	9144 23A2 38
355	350		9144 24E2 35	
400	400		9144 25E2 35	

 Flachdichtring mit Stahl-Einlage  
Flat gasket with steel-inlay

D [mm]	DN [mm]	EPDM-St	NBR-St
		Wasser/Water	Gas/Gas
		SDR11	SDR11
110	100	9203 14F1 35	9203 14F2 35
140	125	9203 16F1 35	9203 16F2 35
160	150	9203 17F1 35	9203 17F2 35
180	150	9203 18F1 35	9203 18F2 35
200	200	9203 19F1 35	9203 19F2 35
225	200	9203 20F1 35	9203 20F2 35
250	250	9203 21F1 35	9203 21F2 35
280	250	9203 22F1 35	9203 22F2 35
315	300	9203 23F1 35	9203 23F2 35
355	350	9203 24F1 35	9203 24F2 35
400	400	9203 25F1 35	9203 25F2 35
450	450	9203 26F1 35	9203 26F2 35
500	500	9203 27F1 35	9203 27F2 35

**PP-RCT E-Muffe**

**PP-RCT E-Socket**

**Beschreibung**

PP-RCT Heizwendel Schweißmuffe, gespritzt, SDR7,4 – 17, monofilare, d20 – 500

**Werkstoff**

PP-RCT (Polypropylen Random-Copolymer Temperature-resistant) mit modifizierter Kristallstruktur (beta nukleiert) und erhöhter Temperaturbeständigkeit, Borealis RA7050, Farbe RAL 6024 Verkehrsgrün.  
Das Material entspricht den Anforderungen der aktuellen KTW-Leitlinie des Umweltbundesamtes (UBA).

**Geometrische Eigenschaften**

Innendurchmesser und Wanddicke entsprechend DIN EN ISO 15874.  
Toleranzen bei den Z-Maßangaben sind abhängig von der Dimension. Bis d/D 160 = +/- 3 mm. Ab d/D 180 = +/- 10 mm.

**Betriebsdruck**

Entsprechend der SDR-Klasse des Rohres / der Muffe. Anwendungsklasse nach DIN EN ISO 15874: siehe nachfolgende Tabelle.

**Ausführung**

Geeignet für Heizwendel-Muffen-Schweißung nach DVS Richtlinie 2207. Schweiß-Geräte und Schweiß-Werkzeuge sollten der DVS Richtlinie 2208 entsprechen.

**Description**

PP-RCT Electrofusion socket, injection moulded, SDR7,4 – 17, monofilare, d20 - 500

**Material**

PP-RCT (Polypropylene Random-Copolymer Temperature-resistant) with modified crystalline structure (beta nucleated) and increased temperature resistance, Borealis RA7050, colour RAL 6024 traffic green.  
The material complies with the requirements of the KTW guideline of the German Federal Environmental Agency (UBA).

**Geometric Properties**

Inside diameter and wall thickness according to DIN EN ISO 15874.  
Tolerances of z-sizes depends on the dimension. Up to d/D 160 = +/- 3 mm and from d/D 180 = +/- 10 mm.

**Working pressure**

According to the SDR-class of the pipe / socket. Application class according to DIN EN ISO 15874: see following table.

**Type**

Suitable for electrofusion-socket-welding according to DVS technical code 2207. Welding equipment according to DVS technical code 2208.

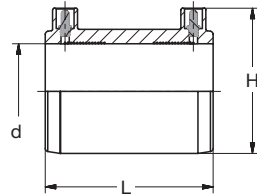

G 8271B PP-RCT E-Muffe grün  
PP-RCT E-Socket green

Druck • Pressure      Schweißparameter • Welding parameter

Teil / Item	d [mm]	L [mm]	H [mm]	SDR	KG	VE1	VE2	Schweißparameter • Welding parameter				
								15874-2: Class 1 [bar]	R (23°C) [Ohm]	RMS [Volt]	Schweißzeit [sec]	Abkühlzeit [min]
7HM2 0600 21	20	70	52	7,4	0,04	1	-	10	0,76	11	65	10
7HM2 0700 21	25	70	57	7,4	0,05	1	-	10	0,76	13	55	10
7HM2 0800 21	32	80	65	7,4	0,07	1	-	10	1,25	20	55	10
7HM2 0900 21	40	90	74	7,4	0,10	1	-	10	1,90	24	105	10
7HM2 1000 21	50	100	85	7,4	0,16	1	-	10	1,41	24	150	15
7HM2 1100 21	63	110	97	7,4	0,26	1	-	10	0,85	24	145	15
7HM2 1200 21	75	120	114	7,4	0,41	1	-	10	0,79	24	165	20
7HM2 1300 21	90	130	130	7,4	0,51	1	-	10	0,76	24	210	20
7HM2 1400 21	110	140	152	7,4	0,80	1	-	10	0,57	24	250	20
7HM2 1500 21	125	151	168	7,4	0,95	1	-	10	1,16	40	180	20
7HM2 1700 21	160	176	205	7,4	1,30	1	-	10	0,84	40	270	30
7HM3 1900 21	200	187	245	9	1,90	1	-	8 *	0,56	40	270	30
7HM3 2100 21	250	243	315	9	4,50	1	-	8 *	0,55	40	480	30
7HM3 2300 21	315	280	375	9	10,8	1	-	8 *	0,52	40	600	30
7HM4 2400 21	355	315	435	11	11,8	1	-	8 *	0,50	40	600	30
7HM6 2500 21	400	355	482	17	14,5	1	-	8 *	0,55	42	800	30
7HM5 2600 21	450	350	534	13,6	18,7	1	-	8 *	0,67	44	800	40
7HM5 2700 21	500	360	593	13,6		1	-	8 *				

\* in Anlehnung an • according to DIN EN ISO 15874-2

Kunststoffrohre und Formteile der Linie PP-INDUSTRIAL weisen generell alle Vorteile auf, die sich seit Jahrzehnten in allen Bereichen der industriellen Anwendung bewährt haben. Vor allem die ausgezeichnete Korrosionsbeständigkeit bietet die Gewähr für eine langlebige und beständige Gebrauchsdauer. Charakteristisch sind die hohe chemische Beständigkeit und die guten Langzeiteigenschaften gegenüber vielen Medien.

### Eigenschaften

- Hohe chemische Beständigkeit
- Hohe Korrosionsbeständigkeit
- Hervorragende Verarbeitbarkeit

### Werkstoff

PP (Polypropylen) mit hohem Molekulargewicht und hoch wärmestabilisiert, RAL 7032 Kieselgrau.

### Verbindungstechnik

- Heizelement-Stumpf-Schweißung
- Heizelement-Muffen-Schweißung
- Heizwendel-Muffen-Schweißung
- Flanschverbindung



## 5 PP-INDUSTRIAL

Plastic pipes and fittings in the line PP-INDUSTRIAL generally have all of the advantages, which have been approved and tested for decades in all areas of industrial applications. Particularly the outstanding resistance of corrosion guarantees a long-lasting and durable service life. Advantages are a high resistance to chemicals and good long-term properties compared to many other media are characteristic.

### Properties

- High chemical resistance
- High corrosion resistance
- Excellent processing capability

### Material

PP (Polypropylene) with a high molecular weight and high heat stabilisation, RAL 7032 pebble grey.

### Joining technology

- Butt-welding
- Socket-welding
- Electrofusion socket-welding
- Flange connection



## 5.01 Rohre • Pipes

5.01.01 Rohre einlagig  
Pipes single-layer **IND 4**



5.01.02 Rohre mehrlagig  
Pipes multi-layer **IND 6**

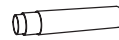

## 5.02 Formteile Muffen-Schweißen Fittings socket-welding

5.02.01 Winkel • Elbows **IND 7**

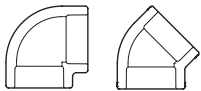

5.02.02 T-Stücke + Abzweige  
Tee's + Branches **IND 8**

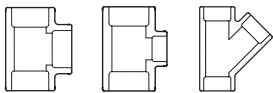

5.02.03 Reduktionen, Muffen, Kappen  
Reducers, Sockets, Caps **IND 9**

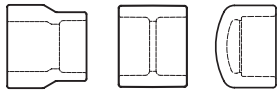

5.02.04 Verschraubungen • Unions **IND 10**



5.02.05 Flanschverbindung Muffe  
Flange connection socket **IND 11**

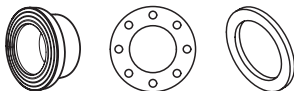

5.02.06 Kugelhähne • Ball Valves **IND 12**

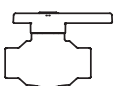

## 5.03 Formteile Stumpf-Schweißen Fittings butt-welding

5.03.01 Bögen + Winkel  
Bends + Elbows **IND 13**

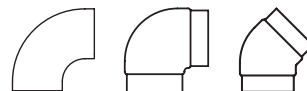

5.03.02 T-Stücke • Tee's **IND 14**

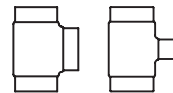

5.03.03 Reduktionen • Reducers **IND 15**



5.03.04 Übergänge • Transitions **IND 16**

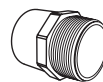

5.03.05 Verschraubungen  
Unions **IND 17**

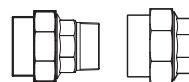

5.03.06 Flanschverbindung  
Flange connection **IND 19**

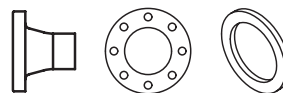

5.04 Armaturen • Valves **IND 21**

**5.01.01 Rohre einlagig • Pipes single-layer**
**PP-INDUSTRIALTEC Druckrohr SDR11 grau 5m**
**PP-INDUSTRIALTEC Pressure Pipe SDR11 grey 5m**
**Beschreibung**

PP-R Druckrohr, SDR11.

**Werkstoff**

PP-R (Polypropylen Random-copolymer), Borealis RA130E, mit hohem Molekulargewicht und hoch wärmostabilisiert, RAL 7032 Kieselgrau.

Das Material entspricht den Anforderungen der aktuellen KTW-Leitlinie des Umweltbundesamtes (UBA).

**Geometrische Eigenschaften und Nenndrücke**

Außendurchmesser und Wanddicke nach DIN 8077 und DIN EN ISO 15494.

**Zertifizierung**

B-R Rohre unterliegen regelmäßigen internen Qualitätskontrollen.

**Lieferung**

In 5 m Stangen und abgepackt in Bunden oder einzelverpackt. Alle Rohre/Bunde sind in schwarzer UV-Schutz-Schlauchfolie verpackt. Abgabe erfolgt nur in kompletten Verpackungseinheiten (VE's).

**Description**

PP-R Pressure Pipe, SDR11

**Material**

PP-R (Polypropylene Random-copolymer), Borealis RA130E, with a high molecular weight and high heat stabilisation, RAL 7032 pebble grey.

The material complies with the requirements of the KTW-guideline of the German Federal Environmental Agency (UBA).

**Geometric Properties and Nominal Pressure**

Outside diameter and wall thickness according to DIN 8077 and DIN EN ISO 15494.

**Certification**

B-R pipes succumb frequent internal quality controls.

**Delivery**

In 5 m rods and packed in bundles or individual. All pipes/bundles are packed in black UV-protection-foil. Supply only in complete packing units (VE's).

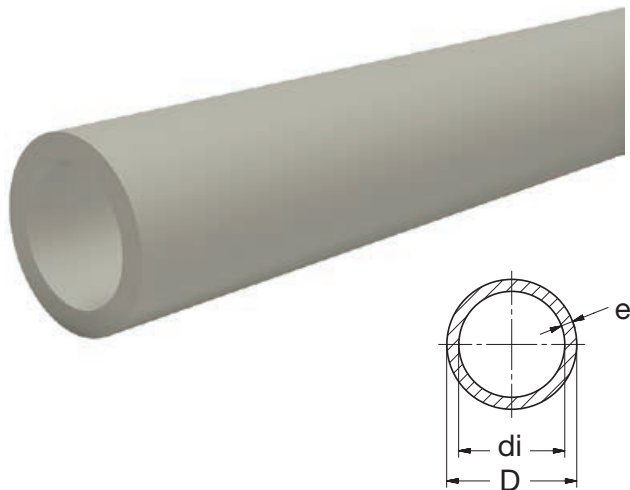
 BG 8100 PP-INDUSTRIALTEC Druckrohr SDR11 grau 5m  
 PP-INDUSTRIALTEC Pressure Pipe SDR11 grey 5m

Teil / Item	D [mm]	e [mm]	DN [mm]	di [mm]	SDR	L [m]	KG [m]	VE1 [m]	VE2 [m]
5114 0650 18	20	1,9	15	16,2	11	5	0,11	125	-
5114 0750 18	25	2,3	20	20,4	11	5	0,16	125	-
5114 0850 18	32	2,9	25	26,2	11	5	0,26	75	-
5114 0950 18	40	3,7	32	32,6	11	5	0,41	50	-
5114 1050 18	50	4,6	40	40,8	11	5	0,64	25	-
5114 1150 18	63	5,8	50	51,4	11	5	1,01	25	-
5114 1250 18	75	6,8	-	61,4	11	5	1,41	10	-
5114 1350 18	90	8,2	65	73,6	11	5	2,03	10	-
5114 1450 18	110	10,0	80	90,0	11	5	3,01	10	-
5114 1550 18	125	11,4	100	102,2	11	5	3,91	5	-
5114 1650 18	140	12,7	-	114,6	11	5	4,87	5	-
5114 1750 18	160	14,6	125	130,8	11	5	6,38	5	-
5114 1850 18	180	16,4	-	147,2	11	5	8,07	5	-
5114 1950 18	200	18,2	160	163,6	11	5	9,95	5	-
5114 2050 18	225	20,5	-	184,0	11	5	12,6	5	-
5114 2150 18	250	22,7	200	204,6	11	5	15,5	5	-
5114 2250 18	280	25,4	-	229,2	11	5	19,4	5	-
5114 2350 18	315	28,6	250	257,8	11	5	24,6	5	-

**PP-INDUSTRIALTEC-CT Druckrohr SDR11 grau 5m**
**PP-INDUSTRIALTEC-CT Pressure Pipe SDR11 grey 5m**
**Beschreibung**

PP-RCT Druckrohr, SDR11, mit einer bis zu 60% höheren Druckbelastbarkeit gegenüber Druckrohr aus PP-R.

**Werkstoff**

PP-RCT (Polypropylene Random-copolymer Crystalline-structure Temperature-resistant), Borealis RA7050LG, mit hohem Molekulargewicht und hoch wärmostabilisiert, RAL 7032 Kieselgrau.

Das Material entspricht den Anforderungen der aktuellen KTW-Leitlinie des Umweltbundesamtes (UBA).

**Geometrische Eigenschaften und Nenndrücke**

Außendurchmesser und Wanddicke nach DIN 8077 und DIN EN ISO 15494.

**Zertifizierung**

B-R Rohre unterliegen regelmäßigen internen und externen Qualitätskontrollen.

**Lieferung**

In 5 m Stangen und abgepackt in Bündeln oder einzelverpackt. Alle Rohre/Bündel sind in schwarzer UV-Schutz-Schlauchfolie verpackt. Abgabe erfolgt nur in kompletten Verpackungseinheiten (VE's).

**Description**

PP-RCT Pressure Pipe, SDR11, with a 60% higher pressure rate compared to PP-R pressure pipes.

**Material**

PP-RCT (Polypropylene Random-copolymer Crystalline-structure Temperature-resistant), Borealis RA7050LG, with a high molecular weight and high heat stabilisation, RAL 7032 pebble grey.

The material complies with the requirements of the KTW-guideline of the German Federal Environmental Agency (UBA).

**Geometric Properties and Nominal Pressure**

Outside diameter and wall thickness according to DIN 8077 and DIN EN ISO 15494.

**Certification**

B-R pipes succumb frequent internal and external quality controls.

**Delivery**

In 5 m rods and packed in bundles or individual. All pipes/bundles are packed in black UV-protection-foil. Supply only in complete packing units (VE's).

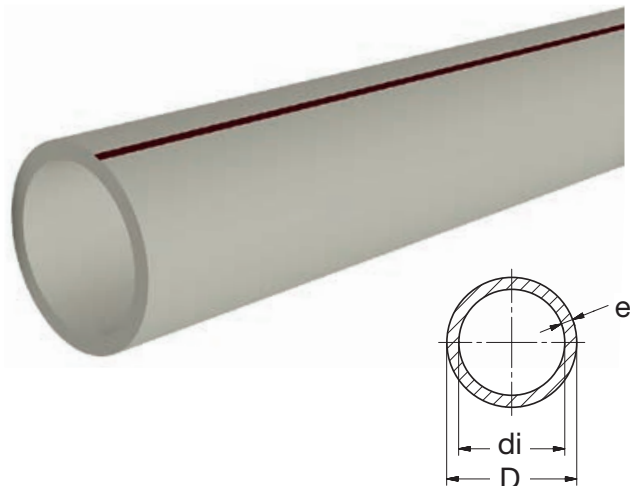
**PP-INDUSTRIALTEC-CT Druckrohr SDR11 grau 5m**
**PP-INDUSTRIALTEC-CT Pressure Pipe SDR11 grey 5m**

Teil / Item	D [mm]	e [mm]	DN [mm]	di [mm]	SDR	L [m]	kg [m]	VE1 [m]	VE2 [m]
7114 0650 18	20	1,9	15	16,2	11	5	0,11	125	-
7114 0750 18	25	2,3	20	20,4	11	5	0,16	125	-
7114 0850 18	32	2,9	25	26,2	11	5	0,26	75	-
7114 0950 18	40	3,7	32	32,6	11	5	0,41	50	-
7114 1050 18	50	4,6	40	40,8	11	5	0,64	25	-
7114 1150 18	63	5,8	50	51,4	11	5	1,01	25	-
7114 1250 18	75	6,8	-	61,4	11	5	1,41	10	-
7114 1350 18	90	8,2	65	73,6	11	5	2,03	10	-
7114 1450 18	110	10,0	80	90,0	11	5	3,01	10	-
7114 1550 18	125	11,4	100	102,2	11	5	3,91	5	-
7114 1650 18	140	12,7	-	114,6	11	5	4,87	5	-
7114 1750 18	160	14,6	125	130,8	11	5	6,38	5	-
7114 1850 18	180	16,4	-	147,2	11	5	8,07	5	-
7114 1950 18	200	18,2	160	163,6	11	5	9,95	5	-
7114 2050 18	225	20,5	-	184,0	11	5	12,6	5	-
7114 2150 18	250	22,7	200	204,6	11	5	15,5	5	-
7114 2250 18	280	25,4	-	229,2	11	5	19,4	5	-
7114 2350 18	315	28,6	250	257,8	11	5	24,6	5	-

**PP-INDUSTRIALTEC-CTplus Druckrohr SDR11 grau 5m**
**PP-INDUSTRIALTEC-CTplus Pressure Pipe SDR11 grey 5m**
**Beschreibung**

PP-RCT Druckrohr, SDR11, mit einer bis zu 60% höheren Druckbelastbarkeit gegenüber Druckrohr aus PP-R, plus einer Faser-Mittelschicht zur Reduzierung der axialen Längenausdehnung um bis zu Faktor 4 gegenüber einlagigen Rohren.

**Werkstoff**

PP-RCT (Polypropylene Random-copolymer Crystalline-structure Temperature-resistant), Borealis RA7050LG, mit hohem Molekulargewicht und hoch wärmostabilisiert, RAL 7032 Kieselgrau.

Das Material entspricht den Anforderungen der aktuellen KTW-Leitlinie des Umweltbundesamtes (UBA).

**Geometrische Eigenschaften**

Außendurchmesser und Wanddicke nach DIN 8077 und DIN EN ISO 15494.

**Zertifizierung**

B-R Rohre unterliegen regelmäßigen internen und externen Qualitätskontrollen.

**Lieferung**

In 5 m Stangen und abgepackt in Bündeln oder einzelverpackt. Alle Rohre/Bünde sind in schwarzer UV-Schutz-Schlauchfolie verpackt. Abgabe erfolgt nur in kompletten Verpackungseinheiten (VE's).

**Description**

PP-RCT Pressure Pipe, SDR11, with a 60% higher pressure rate compared to PP-R pressure pipes, plus a fiber-middle-layer for reducing the axial elongation by up to a factor of 4 compared to single-layered pipes.

**Material**

PP (Polypropylene Random-copolymer Crystalline-structure Temperature-resistant), Borealis RA7050LG, with a high molecular weight and high heat stabilisation, RAL 7032 pebble grey.

The material complies with the requirements of the KTW guideline of the German Federal Environmental Agency (UBA).

**Geometric Properties**

Outside diameter and wall thicknesses according to DIN 8077 and DIN EN ISO 15494.

**Certification**

B-R pipes succumb frequent internal and external quality controls.

**Delivery**

In 5 m rods and packed in bundles or individual. All pipes/bundles are packed in black UV-protection-foil. Supply only in complete packing units (VE's).

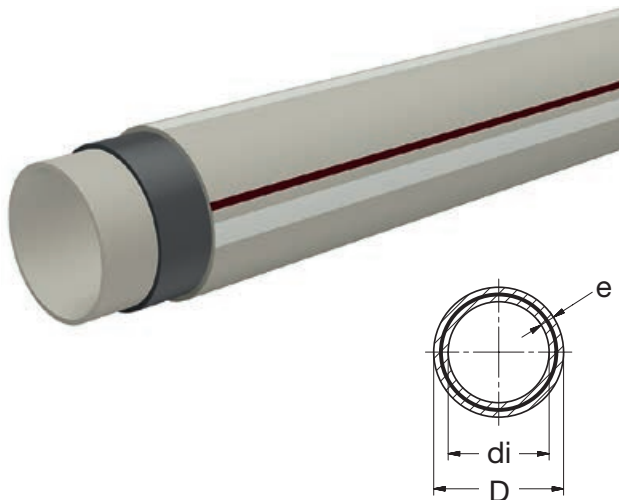
**PP-INDUSTRIALTEC-CTplus Druckrohr SDR11 grau 5m**
**PP-INDUSTRIALTEC-CTplus Pressure Pipe SDR11 grey 5m**

Teil / Item	D [mm]	e [mm]	DN [mm]	di [mm]	SDR	L [m]	kg [m]	VE1 [m]	VE2 [m]
7F12 0650 18	20	2,8	-	14,4	7,4	5	0,15	125	-
7F12 0750 18	25	3,5	15	18,0	7,4	5	0,23	125	-
7F13 0850 18	32	3,6	25	24,8	9	5	0,31	75	-
7F14 0950 18	40	3,7	32	32,6	11	5	0,41	50	-
7F14 1050 18	50	4,6	40	40,8	11	5	0,64	25	-
7F14 1150 18	63	5,8	50	51,4	11	5	1,01	25	-
7F14 1250 18	75	6,8	-	61,4	11	5	1,41	10	-
7F14 1350 18	90	8,2	65	73,6	11	5	2,03	10	-
7F14 1450 18	110	10,0	80	90,0	11	5	3,01	10	-
7F14 1550 18	125	11,4	100	102,2	11	5	3,91	5	-
7F14 1650 18	140	12,7	-	114,6	11	5	4,87	5	-
7F14 1750 18	160	14,6	125	130,8	11	5	6,38	5	-
7F14 1850 18	180	16,4	-	147,2	11	5	8,07	5	-
7F14 1950 18	200	18,2	160	163,6	11	5	9,95	5	-
7F14 2050 18	225	20,5	-	184,0	11	5	12,6	5	-
7F14 2150 18	250	22,7	200	204,6	11	5	15,5	5	-
7F14 2250 18	280	25,4	-	229,2	11	5	19,4	5	-
7F14 2350 18	315	28,6	250	257,8	11	5	24,6	5	-

**PP-INDUSTRIAL Formteile mit Schweißmuffen grau**  
 gespritzt, für die Heizelement-Muffen-Schweißung

**PP-INDUSTRIAL Fittings with welding sockets grey**  
 injection moulded, for socket-welding

**Werkstoff**

Polypropylen, RAL 7032 Kieselgrau.

**Geometrische Eigenschaften**

Außendurchmesser und Wanddicke in Anlehnung an DIN EN ISO 15494 (Formteile) und DIN EN ISO 15494/DIN 8077 (Rohre).

Toleranzen bei den Z-Maßangaben sind abhängig von der Dimension. Bis d/D 160 = +/- 3 mm. Ab d/D 180 = +/- 10 mm.

**Ausführung**

Geeignet für Heizelement-Muffen-Schweißung nach DVS Richtlinie 2207.

Schweiß-Geräte und Schweiß-Werkzeuge sollten der DVS Richtlinie 2208 entsprechen.

**Material**

Polypropylene, RAL 7032 pebble grey.

**Geometric Properties**

Outside diameter and wall thickness according to DIN EN ISO 15494 (Fittings) and DIN EN ISO 15494/DIN 8077 (Pipes).

Tolerances of z-sizes depends on the dimension.

Up to d/D 160 = +/- 3 mm and from d/D 180 = +/- 10 mm.

**Type**

Suitable for socket-welding according to DVS technical code 2207. Welding equipment according to DVS technical code 2208.

### 5.02.01 Winkel • Elbows

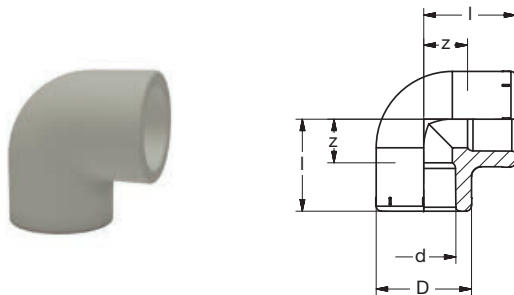

BG 8090 PP-INDUSTRIAL Winkel 90° grau  
 PP-INDUSTRIAL Elbow 90° grey

Teil / Item	d [mm]	D [mm]	l [mm]	z [mm]	KG	VE1	VE2
5411 0690 18	20	29	28	13	0,019	10	120
5411 0790 18	25	34	32	16	0,025	10	80
5411 0890 18	32	43	38	20	0,047	10	80
5411 0990 18	40	52	44	23	0,073	5	50
5411 1090 18	50	65	52	28	0,14	10	60
5411 1190 18	63	84	62	34	0,27	4	32
5411 1290 18	75	101	71	41	0,44	2	18
5411 1390 18	90	120	83	50	0,79	2	12
5411 1490 18	110	148	99	62	1,30	1	3

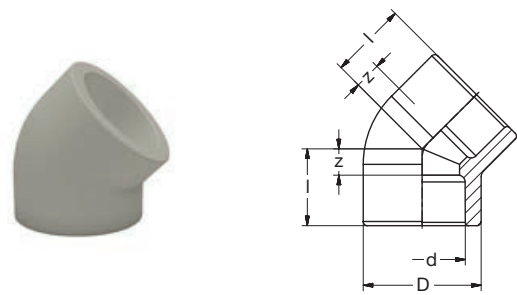

BG 8041 PP-INDUSTRIAL Winkel 45° grau  
 PP-INDUSTRIAL Elbow 45° grey

Teil / Item	d [mm]	D [mm]	l [mm]	z [mm]	KG	VE1	VE2
5411 0645 18	20	29	21	6	0,014	10	150
5411 0745 18	25	34	24	8	0,019	10	90
5411 0845 18	32	43	28	10	0,034	10	50
5411 0945 18	40	52	32	11	0,056	5	30
5411 1045 18	50	65	37	13	0,10	5	45
5411 1145 18	63	82	44	16	0,21	2	40
5411 1245 18	75	99	50	20	0,32	2	24
5411 1345 18	90	120	58	25	0,58	1	10
5411 1445 18	110	148	69	32	0,98	1	4

## 5.02.02 T-Stücke + Abzweige • Tee's + Branches

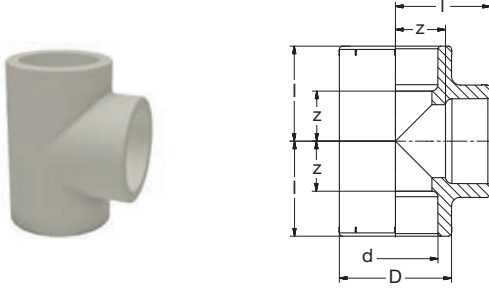

BG 8130 PP-INDUSTRIAL T-Stück 90° grau  
PP-INDUSTRIAL Tee 90° grey

Teil / Item	d [mm]	D [mm]	l [mm]	z [mm]	KG	VE1	VE2
5511 0690 18	20	29	28	13	0,023	10	
5511 0790 18	25	34	32	16	0,034	10	
5511 0890 18	32	43	38	20	0,060	10	
5511 0990 18	40	52	44	23	0,090	10	
5511 1090 18	50	65	52	28	0,17	10	
5511 1190 18	63	84	62	34	0,34	2	
5511 1290 18	75	100	71	41	0,54	2	
5511 1390 18	90	120	83	50	0,95	2	
5511 1490 18	110	148	99	62	1,56	2	

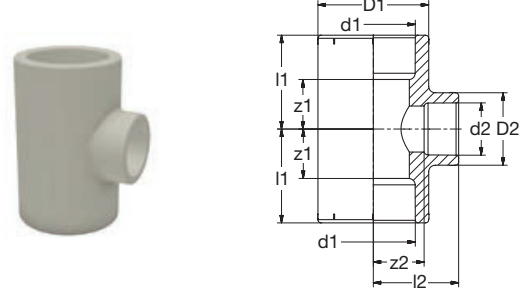

BG 8130 red. PP-INDUSTRIAL T-Stück 90° red grau  
PP-INDUSTRIAL Tee 90° red grey

Teil / Item	d1 - d2 [mm]	D1 [mm]	D2 [mm]	l1 [mm]	l2 [mm]	z1 [mm]	z2 [mm]	KG	VE1	VE2
5521 0706 18	25-20	34	29	32	32	16	17	0,035	10	
5521 0806 18	32-20	43	29	38	36	20	21	0,060	10	
5521 0807 18	32-25	43	34	38	36	20	22	0,060	10	
5521 0906 18	40-20	52	43	44	39	24	24	0,083	10	
5521 0907 18	40-25	52	43	44	40	23	24	0,086	10	
5521 0908 18	40-32	52	43	44	40	23	22	0,091	10	
5521 1007 18	50-25	65	43	52	46	28	30	0,16	10	
5521 1008 18	50-32	65	43	52	46	28	28	0,16	10	
5521 1009 18	50-40	85	85	62	62	39	35	0,16	10	
5521 1107 18	63-25	85	43	62	62	35	46	0,31	2	
5521 1108 18	63-32	85	43	62	62	35	44	0,31	2	
5521 1109 18	63-40	85	85	62	62	35	42	0,32	2	
5521 1110 18	63-50	85	85	62	62	35	39	0,32	2	
5521 1208 18	75-32	100	43	71	71	41	53	0,50	2	
5521 1209 18	75-40	100	65	71	71	41	51	0,50	2	
5521 1210 18	75-50	100	65	71	71	41	48	0,51	2	
5521 1211 18	75-63	100	101	71	71	41	44	0,52	2	
5521 1311 18	90-63	85	83	83	50	50	53	0,91	2	
5521 1312 18	90-75	120	100	83	83	50	53	0,91	2	

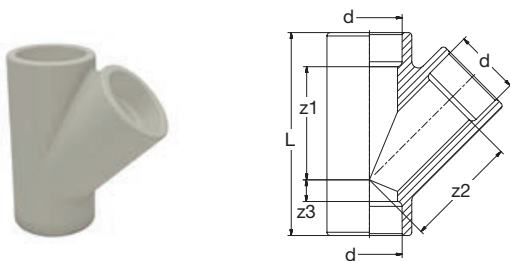

PP-INDUSTRIAL Abzweig 45° 20°C/1.0MPa grau  
PP-INDUSTRIAL Branch 45° 20°C/1.0MPa grey

Teil / Item	d [mm]	L [mm]	z1 [mm]	z2 [mm]	z3 [mm]	KG	VE1	VE2
5511 0845 18	32	89	40	41	11	0,062	10	
5511 0945 18	40	122	65	64	16	0,15	10	
5511 1045 18	50	131	67	67	18	0,23	10	
5511 1145 18	63	169	91	89	23	0,50	2	

## 5.02.03 Reduktionen, Muffen, Kappen • Reducers, Sockets, Caps

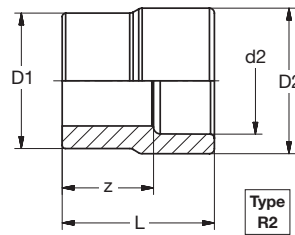
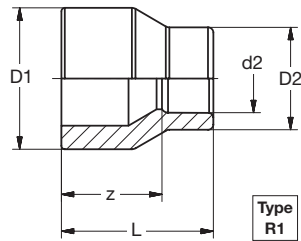

BG 8243 PP-INDUSTRIAL Reduktion grau  
PP-INDUSTRIAL Reducer grey

Teil / Item	D1-d2 [mm]	Type R1 R2	D2 [mm]	L [mm]	z [mm]	KG	VE1	VE2
5321 0706 18	25-20	•	29	36	22	0,012	10	
5321 0806 18	32-20	•	29	37	23	0,015	10	
5321 0807 18	32-25	•	34	39	23	0,017	10	
5321 0906 18	40-20	•	34	43	28	0,023	10	
5321 0907 18	40-25	•	34	43	27	0,023	10	
5321 0908 18	40-32	•	43	45	27	0,029	10	
5321 1006 18	50-20	•	43	51	36	0,043	10	
5321 1007 18	50-25	•	43	51	35	0,043	10	
5321 1008 18	50-32	•	43	51	33	0,045	10	
5321 1009 18	50-40	•	52	53	33	0,055	10	
5321 1106 18	63-20	•	34	56	42	0,079	5	
5321 1107 18	63-25	•	34	56	40	0,076	5	
5321 1108 18	63-32	•	43	58	40	0,076	5	
5321 1109 18	63-40	•	52	60	40	0,084	5	
5321 1110 18	63-50	•	65	63	40	0,091	5	
5321 1210 18	75-50	•	65	67	44	0,12	2	
5321 1211 18	75-63	•	80	71	44	0,15	2	
5321 1309 18	90-50	•	65	74	51	0,15	2	
5321 1310 18	90-63	•	80	78	51	0,17	2	
5321 1311 18	90-75	•	99	81	51	0,23	2	
5321 1411 18	110-63	•	85	87	60	0,32	2	
5321 1412 18	110-75	•	100	90	60	0,37	2	
5342 1413 18	110-90	•	120	93	61	0,45	2	

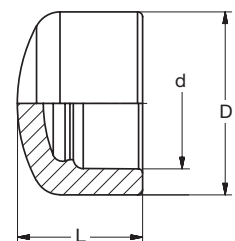
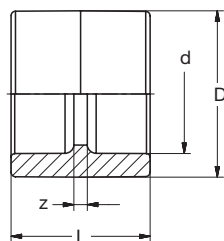

BG 8270 PP-INDUSTRIAL Muffe grau  
PP-INDUSTRIAL Socket grey

Teil / Item	d [mm]	D [mm]	L [mm]	z [mm]	KG	VE1	VE2
5311 0600 18	20	29	34	5	0,010	10	
5311 0700 18	25	34	37	5	0,015	10	
5311 0800 18	32	43	41	5	0,026	10	
5311 0900 18	40	52	46	5	0,047	10	
5311 1000 18	50	65	52	5	0,070	10	
5311 1100 18	63	84	60	5	0,13	2	
5311 1200 18	75	101	65	5	0,20	2	
5311 1300 18	90	120	76	10	0,35	2	
5311 1400 18	110	148	80	5	0,57	2	

BG 8301 PP-INDUSTRIAL Kappe grau  
PP-INDUSTRIAL Cap grey

Teil / Item	d [mm]	D [mm]	L [mm]	KG	VE1	VE2
5341 0690 18	20	29	25	0,009	10	
5341 0790 18	25	34	28	0,013	10	
5341 0890 18	32	43	32	0,021	10	
5341 0990 18	40	52	36	0,033	10	
5341 1090 18	50	65	41	0,057	10	
5341 1190 18	63	79	48	0,090	2	
5341 1290 18	75	99	54	0,18	2	
5341 1390 18	90	120	66	0,35	2	
5341 1490 18	110	148	79	0,59	2	

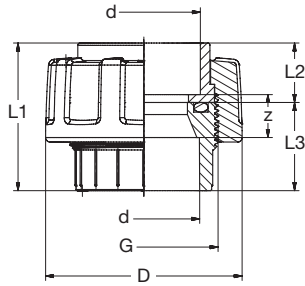

BG 8330A PP-INDUSTRIAL Verschraubung Runddichtring-EPDM grau  
 PP-INDUSTRIAL Union O-Ring-gasket-EPDM grey

Teil / Item	d [mm]	D [mm]	G [Inch]	L1 [mm]	L2 [mm]	L3 [mm]	z [mm]	KG	VE1	VE2
5351 0600 38	20	46	1	44,0	17,5	26	15	0,039	1	150
5351 0700 38	25	56	1 1/4	47,5	19,0	28	15	0,061	1	125
5351 0800 38	32	66	1 1/2	51,5	21,0	30	15	0,091	1	100
5351 0900 38	40	79	2	58,0	23,5	34	17	0,14	1	60
5351 1000 38	50	87	2 1/4	66,0	26,5	39	19	0,17	1	40
5351 1100 38	63	107	2 3/4	78,5	30,5	47	23	0,28	1	30

Einzelteile • Spare parts

d [mm]	Einlegeteil Insert-part	Schraubteil Screw-part	Überwurfmutter Union-nut	Runddichtring-EPDM O-Ring-gasket-EPDM
20	5351 06E0 18	5351 06S0 18	5351 06U0 18	9205 46R1 35
25	5351 07E0 18	5351 07S0 18	5351 07U0 18	9201 07R1 35
32	5351 08E0 18	5351 08S0 18	5351 08U0 18	9205 48R1 35
40	5351 09E0 18	5351 09S0 18	5351 09U0 18	9205 50R1 35
50	5351 10E0 18	5351 10S0 18	5351 10U0 18	9205 51R1 35
63	5351 11E0 18	5351 11S0 18	5351 11U0 18	9205 54R1 35

## 5.02.05 Flanschverbindung Muffe • Flange connection socket

### Bundbuchse (B-Buchse) in gerillter Ausführung für den Einsatz von Flachdichtungen.

Weitere Informationen zu Flanschen und Dichtungen finden Sie unter 6. Zubehör.

### Flange adaptor socket in grooved design for the use of flat-gaskets.

More information about flanges and gaskets see 6. Accessories.

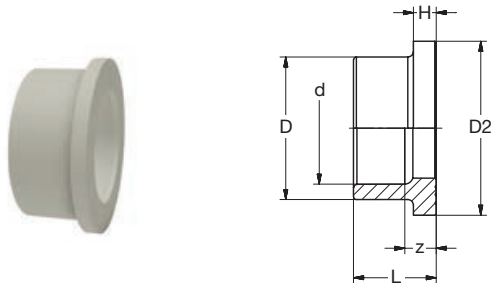

BG 8790 PP-INDUSTRIAL Bundbuchse gerillt grau  
PP-INDUSTRIAL Flange adaptor socket grooved grey

Teil / Item	d [mm]	D [mm]	D2 [mm]	L [mm]	H [mm]	z [mm]	KG	VE1	VE2
5331 09F0 18	40	61	50	29	8	9	0,027	2	
5331 10F0 18	50	74	61	27	8	4	0,043	2	
5331 11F0 18	63	102	76	40	17	13	0,11	2	
5331 12F0 18	75	122	90	38	19	8	0,16	2	
5331 13F0 18	90	137	108	45	21	12	0,25	2	
5331 14F0 18	110	158	131	50	21	13	0,30	2	



### Zubehör Flanschverbindung B-Buchse PP-INDUSTRIAL Accessories Flange connection socket PP-INDUSTRIAL



Losflansch  
Flange loose



Blindflansch  
Flange blind



Flachdichtring mit Stahl-Einlage  
Flat-gasket with steel-inlay

d [mm]	DN [mm]	PP-St	
		DIN/EN	ANSI
40	32	9141 09E1 15	9141 09A2 38
50	40	9141 10E1 15	9141 10A2 38
63	50	9141 11E1 15	9151 11A2 25
75	65	9141 12E1 15	9141 12A2 38
90	80	9142 13E1 15	9141 13A2 38
110	100	9142 14E1 15	9152 14A2 25

PP-St	
DIN/EN	ANSI
9144 09E1 35	9144 09A2 38
9144 10E1 35	9144 10A2 38
9144 11E1 35	9144 11A2 38
9144 12E1 35	9144 12A2 38
9144 13E1 35	9144 13A2 38
9144 14E1 35	9144 14A2 38

EPDM-St		NBR-St	
Wasser/Water		Gas/Gas	
PN10			
9202 09F1 35		9202 09F2 35	
9202 10F1 35		9202 10F2 35	
9202 11F1 35		9202 11F2 35	
9202 12F1 35		9202 12F2 35	
9202 13F1 35		9202 13F2 35	
9202 14F1 35		9202 14F2 35	

## 5.02.06 Kugelhähne • Ball Valves

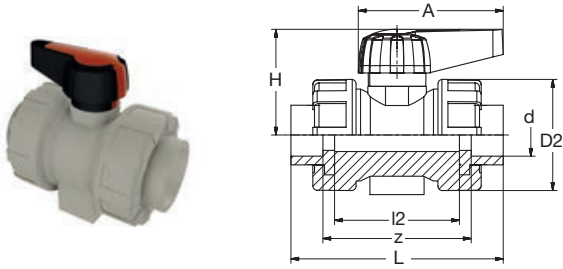

BG 8852 PP-INDUSTRIAL Kugelhahn verschraubt grau  
 PP-INDUSTRIAL Ball valve with union-nuts grey

Teil / Item	d [mm]	D2 [mm]	L [mm]	l2 [mm]	H [mm]	A [mm]	z [mm]	KG	VE1	VE2
591V 06R1 38	20	50,5	96	56,5	48	66,5	67	0,12	1	
591V 07R1 38	25	59	109	65	57	81,5	77	0,19	1	
591V 08R1 38	32	70,5	119	71	65	81,5	83	0,28	1	
591V 09R1 38	40	86	141	85,5	83,5	91,5	100	0,44	1	
591V 10R1 38	50	99,5	153	89	89,5	91,5	106	0,54	1	
591V 11R1 38	63	126	172	101	115	143	117	0,93	1	

mit Runddichtring-EPDM und PTFE-Kugelabdichtung.  
 with O-Ring-gasket-EPDM and PTFE-Ball-valve-sealing.

### PP-INDUSTRIAL Formteile mit Schweißenden SDR11 grau

gespritzt, für die Heizelement-Stumpf-Schweißung

### PP-INDUSTRIAL Fittings with spigots SDR11 grey

injection moulded, for butt-welding

#### Werkstoff

Polypropylen, RAL 7032 Kieselgrau.

#### Geometrische Eigenschaften

Außendurchmesser und Wanddicke in Anlehnung an DIN EN ISO 15494 (Formteile) und DIN EN ISO 15494/DIN 8077 (Rohre).

Toleranzen bei den Z-Maßangaben sind abhängig von der Dimension. Bis d/D 160 = +/- 3 mm. Ab d/D 180 = +/- 10 mm.

#### Ausführung

Geeignet für Heizelement-Stumpfschweißung nach DVS Richtlinie 2207. Schweiß-Geräte und Schweiß-Werkzeuge sollten der DVS Richtlinie 2208 entsprechen.

#### Material

Polypropylene, RAL 7032 pebble grey.

#### Geometric Properties

Outside diameter and wall thickness according to DIN EN ISO 15494 (Fittings) and DIN EN ISO 15494/DIN 8077 (Pipes).

Tolerances of z-sizes depends on the dimension.

Up to d/D 160 = +/- 3 mm and from d/D 180 = +/- 10 mm.

#### Type

Suitable for butt-welding according to DVS technical code 2207. Welding equipment according to DVS technical code 2208.

### 5.03.01 Bögen + Winkel • Bends + Elbows

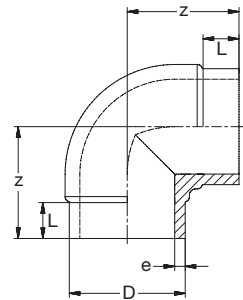
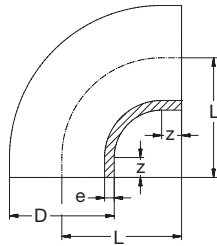

BG 80001 PP-INDUSTRIAL Bogen 90° kurz st **SDR11** grau  
PP-INDUSTRIAL Bend 90° short butt **SDR11** grey

Teil / Item	D [mm]	e [mm]	L [mm]	z [mm]	KG	VE1	VE2
5425 0790 28	25	2,3	5	32	0,009	10	140
5425 0890 28	32	3,0	5	40	0,017	10	80
5425 0990 28	40	3,7	7	51	0,036	10	40
5425 1090 28	50	4,6	7	62	0,066	5	40
5425 1190 28	63	5,8	8	77	0,12	5	50
5425 1290 28	75	6,9	10	85	0,21	2	26
5425 1390 28	90	8,2	10	100	0,36	2	16
5425 1490 28	110	10,0	10	120	0,62	2	8
5425 1590 28	125	11,4	15	140	0,95	1	6
5425 1690 28	140	12,7	15	155	1,30	1	4
5425 1790 28	160	14,6	15	175	1,87	1	3
5425 1890 28	180	16,4	15	195	2,77	1	2
5425 1990 28	200	18,2	15	215	3,60	1	-
5425 2090 28	225	20,5	20	245	5,29	1	-
5425 2190 28	250	22,7	25	275	7,21	1	-
5425 2290 28	280	25,4	30	310	10,0	1	-
5425 2390 28	315	28,6	35	350	14,0	1	-

PP-INDUSTRIAL Winkel 90° kurz st **SDR11** grau  
PP-INDUSTRIAL Elbow 90° short butt **SDR11** grey

Teil / Item	D [mm]	e [mm]	L [mm]	z [mm]	KG	VE1	VE2
5415 0790 18	25	2,3	12	36	0,014	5	180
5415 0890 18	32	3,0	14	39	0,026	5	130

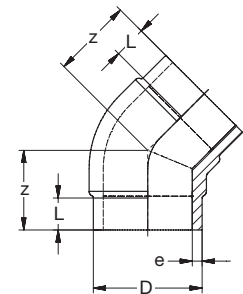

PP-INDUSTRIAL Winkel 45° kurz st **SDR11** grau  
PP-INDUSTRIAL Elbow 45° short butt **SDR11** grey

Teil / Item	D [mm]	e [mm]	L [mm]	z [mm]	KG	VE1	VE2
5415 0745 18	25	2,3	12	21	0,01	10	300
5415 0845 18	32	3,0	14	30	0,02	10	300
5415 1345 18	90	8,2	28	66	0,35	2	20
5415 1445 18	110	10,0	34	79	0,54	2	12

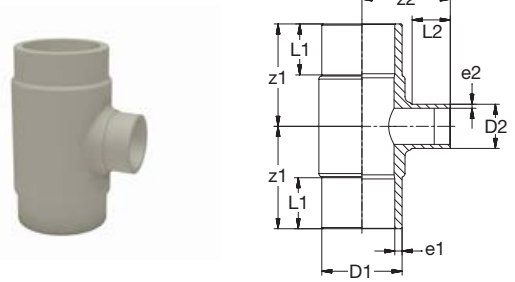
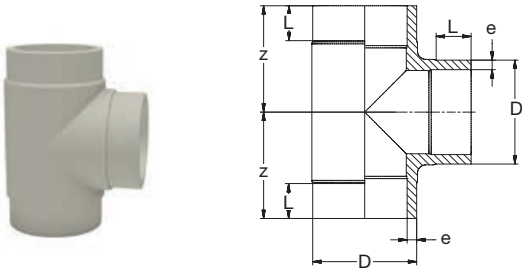

BG 82001 PP-INDUSTRIAL T-Stück 90° kurz st **SDR11** grau  
 PP-INDUSTRIAL Tee 90° short butt **SDR11** grey

Teil / Item	D [mm]	e [mm]	L [mm]	z [mm]	KG	VE1	VE2
5515 0790 18	25	2,3	12	33	0,025	1	
5515 0890 18	32	3,0	14	37	0,040	1	
5515 0990 18	40	3,7	16	42	0,070	1	
5515 1090 18	50	4,6	18	51	0,14	1	
5515 1190 18	63	5,8	22	67	0,22	1	
5515 1290 18	75	6,9	25	75	0,36	1	
5515 1390 28	90	8,2	23	100	0,65	1	
5515 1490 28	110	10,0	43	120	1,04	1	
5515 1590 28	125	11,4	26	125	1,48	1	
5515 1690 28	140	12,7	32	140	2,06	1	
5515 1790 28	160	14,6	40	160	2,95	1	
5515 1890 28	180	16,4	73	195	4,66	1	
5515 1990 28	200	18,2	64	215	6,47	1	
5515 2090 28	225	20,5	72	245	9,22	1	
5515 2190 28	250	22,8	86	275	12,7	1	
5515 2290 28	280	25,5	105	310	18,2	1	
5515 2390 28	315	28,6	111	350	27,7	1	

PP-INDUSTRIAL T-Stück 90° red kurz st **SDR11** grau  
 PP-INDUSTRIAL Tee 90° red short butt **SDR11** grey

Teil / Item	D1-D2 [mm]	e1 [mm]	e2 [mm]	L1 [mm]	L2 [mm]	z1 [mm]	z2 [mm]	KG	VE1	VE2
5525 1108 18	63-32	5,8	3,0	22	15	67	69	0,19	2	6
5525 1411 18	110-63	10,0	5,8	48	32	120	105	0,90	2	6
5525 1413 18	110-90	10,0	8,2	48	38	120	115	0,97	2	6
5525 1714 18	160-110	14,6	10,0	56	38	160	145	2,81	1	-
5525 2014 18	225-110	20,5	10,0	89	88	220	264	7,07	1	-
5525 2015 18	225-125	20,5	11,4	79	32	185	205	6,39	1	-
5525 2017 18	225-160	20,5	14,6	89	60	235	200	7,21	1	-

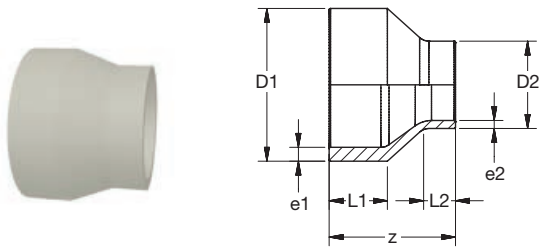

BG 89101 PP-INDUSTRIAL Reduktion kurz st **SDR11** grau  
 PP-INDUSTRIAL Reducer short butt **SDR11** grey

Teil / Item	D1-D2 [mm]	e1 [mm]	e2 [mm]	L1 [mm]	L2 [mm]	z [mm]	KG	VE1	VE2
5325 0807 18	<b>32-25</b>	3,0	2,3	16	14	38	0,010	10	120
5325 0907 18	<b>40-25</b>	3,7	2,3	19	14	47	0,016	10	120
5325 0908 18	<b>40-32</b>	3,7	3,0	19	15	39	0,016	10	40
5325 1008 18	<b>50-32</b>	4,6	3,0	18	14	44	0,029	10	200
5325 1009 18	<b>50-40</b>	4,6	3,7	20	19	46	0,029	10	200
5325 1109 28	<b>63-40</b>	5,8	3,7	25	24	60	0,04	5	120
5325 1110 28	<b>63-50</b>	5,8	4,6	25	27	60	0,05	5	140
5325 1210 28	<b>75-50</b>	6,9	4,6	30	28	70	0,07	2	18
5325 1211 28	<b>75-63</b>	6,9	5,8	30	33	70	0,08	2	20
5325 1310 28	<b>90-50</b>	8,2	4,6	35	28	80	0,10	2	16
5325 1311 28	<b>90-63</b>	8,2	5,8	35	32	80	0,10	2	60
5325 1312 28	<b>90-75</b>	8,2	6,9	35	36	80	0,20	2	60
5325 1411 28	<b>110-63</b>	10,0	5,8	35	35	90	0,20	2	30
5325 1412 28	<b>110-75</b>	10,0	6,9	35	38	90	0,20	2	8
5325 1413 28	<b>110-90</b>	10,0	8,2	35	43	90	0,20	2	24
5325 1512 28	<b>125-75</b>	11,4	6,9	40	39	100	0,30	2	8
5325 1513 28	<b>125-90</b>	11,4	8,2	40	43	100	0,30	2	24
5325 1514 28	<b>125-110</b>	11,4	10,0	40	51	100	0,40	2	16
5325 1613 28	<b>140-90</b>	12,7	8,2	50	39	110	0,50	2	8
5325 1614 28	<b>140-110</b>	12,7	10,0	50	45	110	0,50	2	8
5325 1615 28	<b>140-125</b>	12,7	11,4	50	51	110	0,50	2	8
5325 1713 28	<b>160-90</b>	14,6	8,2	55	40	120	0,70	2	8
5325 1714 28	<b>160-110</b>	14,6	10,0	55	44	120	0,70	2	8
5325 1813 28	<b>180-90</b>	16,4	8,2	60	44	130	0,90	1	8
5325 1816 28	<b>180-140</b>	16,4	12,7	60	50	130	0,90	1	8
5325 1817 28	<b>180-160</b>	16,4	14,6	60	58	130	1,00	1	12
5325 1917 28	<b>200-160</b>	18,2	14,6	60	54	140	1,30	1	8
5325 1918 28	<b>200-180</b>	18,2	16,4	60	63	140	1,30	1	10
5325 2017 28	<b>225-160</b>	20,5	14,8	65	58	160	1,80	1	2
5325 2019 28	<b>225-200</b>	20,5	18,2	65	73	160	1,90	1	3
5325 2117 28	<b>250-160</b>	22,8	14,6	75	63	180	2,50	1	2
5325 2119 28	<b>250-200</b>	22,8	18,2	75	72	180	2,50	1	2
5325 2120 28	<b>250-225</b>	22,8	20,5	75	83	180	2,60	1	2
5325 2219 28	<b>280-200</b>	25,4	18,2	85	72	200	3,60	1	3
5325 2220 28	<b>280-225</b>	25,4	20,5	85	80	200	3,70	1	3
5325 2221 28	<b>280-250</b>	25,4	22,7	85	90	200	3,80	1	5
5325 2320 28	<b>315-225</b>	28,6	20,5	95	88	230	5,20	1	2
5325 2321 28	<b>315-250</b>	28,6	22,7	95	95	230	5,30	1	3
5325 2322 28	<b>315-280</b>	28,6	25,5	95	107	230	5,40	1	4

## 5.03.04 Übergänge • Transitions

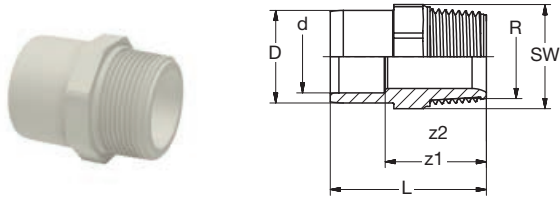

BG 89107 PP-INDUSTRIAL Übergang kurz AG-keg st **SDR11** grau  
 PP-INDUSTRIAL Transition short male-thread-con butt **SDR11** grey

Teil / Item	D x R [mm x Inch]	Thread	L [mm]	z [mm]	SW [mm]	kg	VE1	VE2
5615 0773 18	25 x 1/2	m	45	29	30	0,017	1	10
5615 0775 18	25 x 3/4	m	47	31	32	0,019	1	10
5615 0875 18	32 x 3/4	m	50	31	32	0,026	1	10
5615 0876 18	32 x 1	m	54	35	36	0,031	1	10
5615 0976 18	40 x 1	m	58	36	46	0,044	1	10
5615 0977 18	40 x 1 1/4	m	60	38	46	0,049	1	10
5615 1077 18	50 x 1 1/4	m	65	39	55	0,069	1	10
5615 1078 18	50 x 1 1/2	m	66	40	55	0,075	1	10
5615 1178 18	63 x 1 1/2	m	73	42	65	0,116	1	10
5615 1180 18	63 x 2	m	78	47	65	0,133	1	5

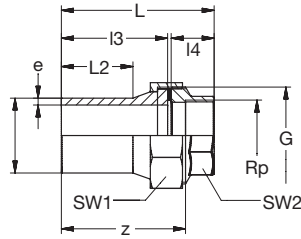

PP-INDUSTRIAL-V2A Ü-Verschraubung lang IG-zyl Flachdichtring-EPDM 20°C/1.0MPa st **SDR11** grau

PP-INDUSTRIAL-Stainless steel Transition-Union long female-thread-cyl flat-gasket-EPDM 20°C/1.0MPa butt **SDR11** grey

Teil / Item	D x Rp [mm x Inch]	e [mm]	G [Inch]	L [mm]	L2 [mm]	l3 [mm]	l4 [mm]	z [mm]	SW1 [mm]	SW2 [mm]	KG	VE1	VE2
5V53 0745 28	25 x 3/4	2,3	1 1/4	82	36	56	23	67	47	32	0,23	1	-
5V53 0846 28	32 x 1	3,0	1 1/2	94	42	65	26	77	52	38	0,28	1	-
5V53 0947 28	40 x 1 1/4	3,7	2	102	45	71	28	83	66	47	0,45	1	-
5V53 1048 18	50 x 1 1/2	4,6	2 1/4	113	52	81	29	94	72	53	0,61	1	-
5V53 1150 18	63 x 2	5,8	2 3/4	126	57	89	34	102	87	65	1,07	1	-
5V53 1253 18	75 x 2 1/2	6,9	3 1/2	179	71	130	46	152	109	82	1,67	1	-
5V53 1355 28	90 x 3	8,2	4	205	76	150	52	175	123	96	2,29	1	-
5V53 1357 28	90 x 4	8,2	5	219	76	164	60	180	150	123	3,10	1	-
5V53 1457 28	110 x 4	10,0	5	233	88	170	60	197	150	123	3,56	1	-

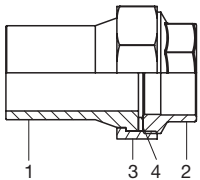

Rohrverschraubung PP-INDUSTRIAL-V2A mit Flachdichtung und Anschluss für Metallgewinde

1. PP Einlegeteil
2. V2A Einschraubteil
3. V2A Überwurfmutter
4. Flachdichtring-EPDM

Union PP-INDUSTRIAL-Stainless steel with flat gasket and connection for metal thread

1. PP Insert-part
2. Stainless steel Screw-part
3. Stainless steel Union-nut
4. Flat-gasket-EPDM

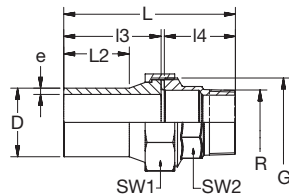

PP-INDUSTRIAL-V2A Ü-Verschraubung lang AG-keg Flachdichtring-EPDM 20°C/1.0MPa st **SDR11** grau

PP-INDUSTRIAL-Stainless steel Transition-Union long male-thread-con flat-gasket-EPDM 20°C/1.0MPa butt **SDR11** grey

Teil / Item	D x R [mm x Inch]	e [mm]	G [Inch]	L [mm]	L2 [mm]	l3 [mm]	l4 [mm]	SW1 [mm]	SW2 [mm]	KG	VE1	VE2
5V53 0775 28	25 x 3/4	2,3	1 1/4	109	36	56	50	47	27	0,26	1	-
5V53 0876 28	32 x 1	3,0	1 1/2	122	42	65	54	52	34	0,38	1	-
5V53 0977 28	40 x 1 1/4	3,7	2	128	45	71	54	66	43	0,59	1	-
5V53 1078 18	50 x 1 1/2	4,6	2 1/4	146	52	81	62	72	50	0,77	1	-
5V53 1180 18	63 x 2	5,8	2 3/4	161	57	89	69	87	61	1,19	1	-
5V53 1283 18	75 x 2 1/2	6,9	3 1/2	152	71	130	78	109	82	2,02	1	-
5V53 1385 28	90 x 3	8,2	4	240	76	150	87	123	96	2,61	1	-
5V53 1387 28	90 x 4	8,2	5	257	76	164	100	150	124	3,90	1	-
5V53 1487 28	110 x 4	10,0	5	273	88	170	100	150	124	4,44	1	-

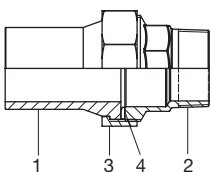

Rohrverschraubung PP-INDUSTRIAL-V2A mit Flachdichtung und Anschluss für Metallgewinde

1. PP Einlegeteil
2. V2A Einschraubteil
3. V2A Überwurfmutter
4. Flachdichtring-EPDM

Union PP-INDUSTRIAL-Stainless steel with flat gasket and connection for metal thread

1. PP Insert-part
2. Stainless steel Screw-part
3. Stainless steel Union-nut
4. Flat-gasket-EPDM

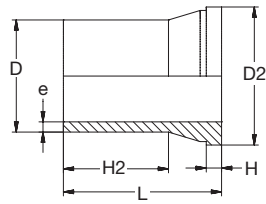

PP-INDUSTRIAL Verschraubung Einlegeteil lang st **SDR11** grau

PP-INDUSTRIAL Union Insert-part long butt **SDR11** grey

Teil / Item	D [mm]	e [mm]	D2 [mm]	L [mm]	L2 [mm]	H [mm]	KG	VE1	VE2
5353 07E0 38	25	2,3	39	87	66	6	0,023	1	-
5353 08E0 38	32	3,0	45	95	66	7	0,036	1	-
5353 09E0 38	40	3,7	57	97	66	8	0,062	1	-
5353 10E0 18	50	4,6	62	115	80	8	0,10	1	-
5353 11E0 18	63	5,8	78	125	85	9	0,17	1	-
5353 12E0 18	75	6,9	97	130	90	12	0,26	1	-
5353 13E0 18	90	8,2	109	144	103	13	0,38	1	-
5353 14E0 18	110	10,0	135	158	105	13	0,62	1	-

## 5.03.06 Flanschverbindung • Flange connection

### Vorschweißbund (V-Bund) kurz in gerillter Ausführung für den Einsatz von Flachdichtungen.

Weitere Informationen zu Flanschen und Dichtungen finden Sie unter 6. Zubehör.

### Flange adaptor spigot short in grooved design for the use of flat-gaskets.

More information about flanges and gaskets see 6. Accessories.

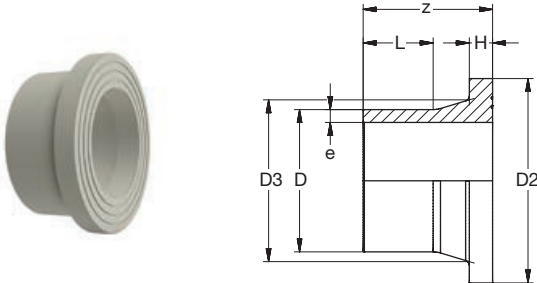
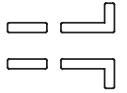

BG 88001

PP-INDUSTRIAL V-Bund kurz gerillt st **SDR11** grau

PP-INDUSTRIAL Flange adaptor spigot short grooved butt **SRD11** grey

Teil / Item	D [mm]	e [mm]	D2 [mm]	D3 [mm]	H [mm]	L min [mm]	z [mm]	kg	VE1	VE2
5335 07F0 18	25	2,3	58	33	9	18	35	0,031	10	170
5335 08F0 18	32	3,0	68	40	10	18	35	0,043	10	140
5335 09F0 18	40	3,7	78	50	11	18	40	0,064	10	150
5335 10F0 18	50	4,6	88	61	12	18	60	0,095	10	90
5335 11F0 18	63	5,8	102	75	14	18	78	0,16	2	12
5335 12F0 18	75	6,9	122	89	16	28	78	0,25	2	36
5335 13F0 18	90	8,2	138	105	17	29	88	0,35	2	24
5335 14F0 18	110	10,0	158	125	18	41	100	0,54	2	12
5335 15F0 18	125	11,4	158	132	25	48	110	0,66	2	10
5335 16F0 18	140	12,7	188	155	25	54	116	0,97	1	8
5335 17F0 18	160	14,6	212	175	25	55	127	1,25	1	6
5335 18F0 18	180	16,4	212	180	30	60	138	1,46	1	4
5335 19F0 18	200	18,2	268	232	32	67	145	2,48	1	3
5335 20F0 18	225	20,5	268	235	32	72	148	2,52	1	3
5335 21F0 18	250	22,7	320	285	35	77	158	3,86	1	2
5335 22F0 18	280	25,4	320	291	35	81	180	4,29	1	2
5335 23F0 18	315	28,6	370	335	35	95	188	6,00	1	-

**Zubehör Flanschverbindung V-Bund PP-INDUSTRIAL  
Accessories Flange Connection spigot PP-INDUSTRIAL**

 Losflansch  
Flange loose

D [mm]	DN [mm]	PP-St		PP-GGG	PP-St
		DIN/EN		ANSI	
		PN10/16	PN10	150 lbs	
25	20	9141 07E1 15			9141 07A2 38
32	25	9141 08E1 15			9141 08A2 38
40	32	9141 09E1 15			9141 09A2 38
50	40	9141 10E1 15			9141 10A2 38
63	50	9141 11E1 15		9151 11A2 25	
75	65	9141 12E1 15			9141 12A2 38
90	80	9143 13E1 15		9153 13A2 25	
110	100	9143 14E1 15		9153 14A2 25	
125	100	9143 15E1 15			9143 14A2 38
140	125	9143 16E1 15			
160	150	9143 17E1 15		9153 17A2 25	
180	150	9143 18E1 15		9153 18A2 35	
200	200		9143 19E2 15	9143 19E3 35	9153 19A2 25
225	200		9143 20E2 15	9143 20E3 35	9153 19A2 25
250	250		9143 21E2 15	9143 21E3 35	9153 21A2 25
280	250		9143 22E2 15	9143 22E3 35	
315	300		9143 23E2 15	9143 23E3 35	9153 23A2 25

 Blindflansch  
Flange blind

D [mm]	DN [mm]	PP-St		PP-St
		DIN/EN		ANSI
		PN10/16	PN10	150 lbs
25	20	9144 07E1 35		9144 07A2 38
32	25	9144 08E1 35		9144 08A2 38
40	32	9144 09E1 35		9144 09A2 38
50	40	9144 10E1 35		9144 10A2 38
63	50	9144 11E1 35		9144 11A2 38
75	65	9144 12E1 35		9144 12A2 38
90	80	9144 13E1 35		9144 13A2 38
110	100	9144 14E1 35		9144 14A2 38
125	100	9144 14E1 35		
140	125	9144 16E1 35		
160	150	9144 17E1 35		9144 17A2 38
180	150	9144 17E1 35		
200	200		9144 19E2 35	9144 19A2 38
225	200		9144 19E2 35	
250	250		9144 21E2 35	9144 21A2 38
280	250		9144 21E2 35	
315	300		9144 23E2 35	9144 23A2 38

 Flachdichtung mit Stahl-Einlage  
Flat gasket with steel-inlay

D [mm]	DN [mm]	EPDM-St	NBR-St
		Wasser/Water	Gas/Gas
		SDR11	SDR11
25	20	9203 07F1 35	9203 07F2 35
32	25	9203 08F1 35	9203 08F2 35
40	32	9203 09F1 35	9203 09F2 35
50	40	9203 10F1 35	9203 10F2 35
63	50	9203 11F1 35	9203 11F2 35
75	65	9203 12F1 35	9203 12F2 35
90	80	9203 13F1 35	9203 13F2 35
110	100	9203 14F1 35	9203 14F2 35
125	100	9203 15F1 35	9203 15F2 35
140	125	9203 16F1 35	9203 16F2 35
160	150	9203 17F1 35	9203 17F2 35
180	150	9203 18F1 35	9203 18F2 35
200	200	9203 19F1 35	9203 19F2 35
225	200	9203 20F1 35	9203 20F2 35
250	250	9203 21F1 35	9203 21F2 35
280	250	9203 22F1 35	9203 22F2 35
315	300	9203 23F1 35	9203 23F2 35

**PP-INDUSTRIAL Ventil Schrägsitz mit Handrad Dichtung-EPDM/FKM grau**
**PP-INDUSTRIAL Valve angle with hand wheel sealing-EPDM/FKM grey**

DN 15 - 50

Schrägsitzventile aus PP sind besonders geeignet als Absperr- und Sicherheitsorgane an Behältern, Rohrleitungen und Pumpenanlagen, insbesondere wo aggressive Medien abzusperrten und zu fördern sind. Die Entstehung von Druckschlägen wird durch das langsame Öffnen der Armatur (Spindelführung) verhindert. Eingesetzt werden diese beispielsweise in der Chemischen Industrie, der Wasser/Abwassertechnik, in Beizanlagen und Abluftreinigungsanlagen.

Inclined-seat valves are made of PP. They are safety devices on containers, pipelines, and pumping plants, particularly when aggressive media have to be controlled. Inclined-seat valves cause almost no water hammer when they are opened. Applications include the chemical industry, pickling plants, exhaust air decontamination plants, and water/waste water processing plants.



Flanschanschluß nach DIN 2501 - PN10  
Flange connection acc. DIN 2501 - PN10



Verschraubung mit Schweißstumpf  
Union with butt-welding spigot



Verschraubung mit Schweißmuffe  
Union with welding-socket

D [mm]	DN [mm]	DN [Inch]	PN [bar]	KG	EPDM		FKM (FPM)		KG	EPDM		FKM (FPM)		KG	EPDM		FKM (FPM)	
					Teil / Item	Teil / Item	Teil / Item	Teil / Item		Teil / Item	Teil / Item	Teil / Item	Teil / Item					
20	15	1/2	10	0,40	593F 061H 38	593F 063H 38	0,23	5933 061H 38	5933 063H 38	0,22	5931 061H 38	5931 063H 38	0,22	5931 061H 38	5931 063H 38	0,26	5931 071H 38	5931 073H 38
25	20	3/4	10	0,46	593F 071H 38	593F 073H 38	0,27	5933 071H 38	5933 073H 38	0,26	5931 071H 38	5931 073H 38	0,26	5931 071H 38	5931 073H 38	0,26	5931 071H 38	5931 073H 38
32	25	1	10	0,62	593F 081H 38	593F 083H 38	0,36	5933 081H 38	5933 083H 38	0,34	5931 081H 38	5931 083H 38	0,34	5931 081H 38	5931 083H 38	0,34	5931 081H 38	5931 083H 38
40	32	1 1/4	10	1,03	593F 091H 38	593F 093H 38	0,60	5933 091H 38	5933 093H 38	0,56	5931 091H 38	5931 093H 38	0,56	5931 091H 38	5931 093H 38	0,56	5931 091H 38	5931 093H 38
50	40	1 1/2	10	1,38	593F 101H 38	593F 103H 38	0,85	5933 101H 38	5933 103H 38	0,77	5931 101H 38	5931 103H 38	0,77	5931 101H 38	5931 103H 38	0,77	5931 101H 38	5931 103H 38
63	50	2	10	2,00	593F 111H 38	593F 113H 38	1,37	5933 111H 38	5933 113H 38	1,26	5931 111H 38	5931 113H 38	1,26	5931 111H 38	5931 113H 38	1,26	5931 111H 38	5931 113H 38

**PP-INDUSTRIAL Ventil Schrägsitz Rückschlag Dichtung-EPDM/FKM grau**
**PP-INDUSTRIAL Valve angle Non-return sealing-EPDM/FKM grey**

DN 15 - 50

Die Schrägsitz Rückschlagventile aus PP zeichnen sich durch ihre Zuverlässigkeit und ihre lagenunabhängige Funktionsweise aus. Diese Funktion und gleichzeitig einfache Wartungsmöglichkeit garantiert ein hohes Maß an Prozesssicherheit.

The Non-return Valves made of PP show their strength with remarkable reliability. The valves work in either vertical or horizontal position. Because of its position-independent function and the simple maintenance process, the valve grants a high degree of process reliability.



Flanschanschluß nach DIN 2501 - PN10  
Flange connection acc. DIN 2501 - PN10



Verschraubung mit Schweißstumpf  
Union with butt-welding spigot



Verschraubung mit Schweißmuffe  
Union with welding-socket

D [mm]	DN [mm]	DN [Inch]	PN [bar]	KG	EPDM		FKM (FPM)		KG	EPDM		FKM (FPM)		KG	EPDM		FKM (FPM)	
					Teil / Item	Teil / Item	Teil / Item	Teil / Item		Teil / Item	Teil / Item	Teil / Item	Teil / Item					
20	15	1/2	10	0,32	593F 061R 38	593F 063R 38	0,23	5933 061R 38	5933 063R 38	0,22	5931 061R 38	5931 063R 38	0,22	5931 061R 38	5931 063R 38	0,26	5931 071R 38	5931 073R 38
25	20	3/4	10	0,40	593F 071R 38	593F 073R 38	0,27	5933 071R 38	5933 073R 38	0,26	5931 071R 38	5931 073R 38	0,26	5931 071R 38	5931 073R 38	0,26	5931 071R 38	5931 073R 38
32	25	1	10	0,62	593F 081R 38	593F 083R 38	0,36	5933 081R 38	5933 083R 38	0,34	5931 081R 38	5931 083R 38	0,34	5931 081R 38	5931 083R 38	0,34	5931 081R 38	5931 083R 38
40	32	1 1/4	10	1,03	593F 091R 38	593F 093R 38	0,60	5933 091R 38	5933 093R 38	0,56	5931 091R 38	5931 093R 38	0,56	5931 091R 38	5931 093R 38	0,56	5931 091R 38	5931 093R 38
50	40	1 1/2	10	1,38	593F 101R 38	593F 103R 38	0,85	5933 101R 38	5933 103R 38	0,77	5931 101R 38	5931 103R 38	0,77	5931 101R 38	5931 103R 38	0,77	5931 101R 38	5931 103R 38
63	50	2	10	2,00	593F 111R 38	593F 113R 38	1,37	5933 111R 38	5933 113R 38	1,26	5931 111R 38	5931 113R 38	1,26	5931 111R 38	5931 113R 38	1,26	5931 111R 38	5931 113R 38

**PP-INDUSTRIAL Schmutzfänger Dichtung-EPDM/FKM grau**
**PP-INDUSTRIAL Dirt traps sealing-EPDM/FKM grey**

DN 15 - 50

Um Armaturen, Sensoren und Pumpen gegen Verschmutzung zu schützen wird der Einsatz von Schmutzfängern aus PP empfohlen. Dies stellt eine lange Lebensdauer und Betriebssicherheit der Komponenten sicher.

To protect valves, sensors and pumps from pollutants, we recommended the use of Strainers made of PP. This ensures reliable operation and extended service life for your components.



Flanschschluß nach DIN 2501 - PN10  
Flange connection acc. DIN 2501 - PN10



Verschraubung mit Schweißstumpf  
Union with butt-welding spigots



Verschraubung mit Schweißmuffen  
Union with welding-sockets

D [mm]	DN [mm]	DN [Inch]	PN [bar]	KG	EPDM		FKM (FPM)		KG	EPDM		FKM (FPM)		KG	EPDM		FKM (FPM)	
					Teil / Item	Teil / Item	Teil / Item	Teil / Item		Teil / Item	Teil / Item	Teil / Item	Teil / Item					
20	15	1/2	10	0,30	593F 061S 38	593F 062S 38	0,13	5933 061S 38	5933 062S 38	0,12	5931 061S 38	5931 062S 38						
25	20	1	10	0,37	593F 071S 38	593F 072S 38	0,17	5933 071S 38	5933 072S 38	0,16	5931 071S 38	5931 072S 38						
32	25	1	10	0,50	593F 081S 38	593F 082S 38	0,24	5933 081S 38	5933 082S 38	0,22	5931 081S 38	5931 082S 38						
40	32	1 1/4	10	0,83	593F 091S 38	593F 092S 38	0,40	5933 091S 38	5933 092S 38	0,36	5931 091S 38	5931 092S 38						
50	40	1 1/2	10	1,10	593F 101S 38	593F 102S 38	0,60	5933 101S 38	5933 102S 38	0,51	5931 101S 38	5931 102S 38						
63	50	2	10	1,50	593F 111S 38	593F 112S 38	0,95	5933 111S 38	5933 112S 38	0,85	5931 111S 38	5931 112S 38						

**PP-INDUSTRIAL Absperrklappen Dichtung-EPDM/FKM grau**
**PP-INDUSTRIAL Butterfly shut-off valves sealing-EPDM/FKM grey**

DN 65 - 300

Absperrklappen aus PP sind dichtschießende Armaturen. Sie werden überall dort eingesetzt, wo große Mengen flüssiger Medien sicher transportiert werden, wie z.B. in der Wasseraufbereitung oder in der chemischen Industrie. Unsere Klappen sind modular aufgebaut und ermöglichen Ihnen jederzeit einen Austausch einzelner Systemteile, das alles schnell, einfach und ohne großen Aufwand. Maximal zulässige Betriebstemperatur PP: 80°C.

The plastic shut-off valves made of PP are leakage free. They can be used wherever large volumes of liquids need to be conveyed safely and reliably, e.g. water treatment or in chemical process industries. Our valves modular design principle allows you to exchange individual system components, fast, easily and at very little expense and effort. Max. operating temperature PP: 80°C.



mit freiem Wellenende  
with free shaft end



mit Handrad + Schneckengetriebe  
with hand-wheel + worm gear



mit Handhebel + Feststellvorrichtung  
with manual lever + fixing device

D [mm]	DN [mm]	DN [Inch]	PN [bar]	KG	EPDM		FKM (FPM)		KG	EPDM		FKM (FPM)		KG	EPDM		FKM (FPM)	
					Teil / Item	Teil / Item	Teil / Item	Teil / Item		Teil / Item	Teil / Item	Teil / Item	Teil / Item					
75	65	2 1/2	10	0,90	595F 121W 38	595F 123W 38	3,10	595F 121S 38	595F 123S 38	1,10	595F 121H 38	595F 123H 38						
90	80	3	10	1,00	595F 131W 38	595F 133W 38	3,30	595F 131S 38	595F 133S 38	1,20	595F 131H 38	595F 133H 38						
110	100	4	10	1,50	595F 141W 38	595F 143W 38	3,80	595F 141S 38	595F 143S 38	1,80	595F 141H 38	595F 143H 38						
160	150	6	8	2,80	595F 171W 38	595F 173W 38	5,00	595F 171S 38	595F 173S 38	3,00	595F 171H 38	595F 173H 38						
225	200	8	6	3,90	595F 201W 38	595F 203W 38	6,20	595F 201S 38	595F 203S 38	4,80	595F 201H 38	595F 203H 38						
280	250	10	6	6,50	595F 221W 38	595F 223W 38	13,50	595F 221S 38	595F 223S 38									
315	300	12	5	11,50	595F 231W 38	595F 233W 38	18,50	595F 231S 38	595F 233S 38									

# 6 Zubehör • Accessories

## 6.01 Flansche • Flanges

6.01.01 Losflansche DIN-EN  
Flanges DIN-EN **ZUB 2**

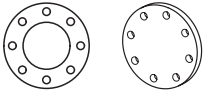

6.01.02 Losflansche ANSI  
Flanges ANSI **ZUB 5**

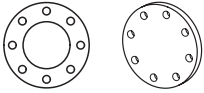

6.01.03 Sonder-Flanschverbindung  
Special Flange connection **ZUB 7**



## 6.02 Dichtungen • Gaskets

6.02.01 Runddichtringe  
O-Ring-Gaskets **ZUB 9**



6.02.02 Flachdichtringe  
Flat-Gaskets **ZUB 9**



6.02.03 Flachdichtringe mit Stahleinlage  
Flat-Gaskets with Steel-inlay **ZUB 10**



6.03 Clipse und Schellen  
Clips and clamps **ZUB 11**

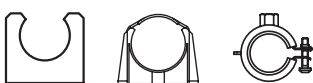

6.04 Montagematerial  
Mounting material **ZUB 13**

## 6.05 Werkzeuge • Installations tools

6.05.01 Schneiden • Cutting **ZUB 14**

6.05.02 Reinigen • Cleaning **ZUB 18**

6.05.03 Kleben • Bonding **ZUB 18**

6.05.04 Heizelement-Muffen-Schweißen  
Socket welding **ZUB 19**

6.05.05 Heizelement-Stumpf-Schweißen  
Butt welding **ZUB 22**

6.05.06 Heizwendel-Muffen-Schweißen  
Electrofusion-socket welding **ZUB 29**

6.05.07 Einschweißsättel  
Weld-in-saddles **ZUB 34**

6.05.08 Schälwerkzeuge Stabitec  
Peeling tools Stabitec **ZUB 36**



6.05.09 Reparatursets • Repair sets **ZUB 36**

6.05.10 Verschiedenes • Miscellaneous **ZUB 37**

6.06 Armaturen • Valves **ZUB 38**



## 6.01 Flansche • Flanges

Bei den Flanschverbindungen finden sich Symbole, die erkennen lassen, welche Rohr-Verbindungs-Formteile mit den Flanschringen benutzt werden können.

-  Bundbuchse
-  Vorschweißbund
-  Bundbuchse + Vorschweißbund

„PN gebohrt“ bedeutet, dass das Lochbild für die Schrauben der angegebenen Druckstufe entspricht.

For the flange connections, there are symbols which indicate which pipe connection fitting with the flange rings can be used.



-  Flange adaptor socket
-  Flange adaptor spigot
-  Flange adaptor socket + spigot

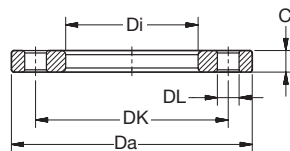

„PN drilled“ means that the hole pattern for the screws corresponds to the indicated pressure step.

### 6.01.01 Losflansche DIN-EN • Flanges DIN-EN



621.70.00 PVC-U Losflansch DIN-EN grau  
PVC-U Backing flange DIN-EN grey

Teil / Item	d [mm]	BB 	VB 	PN [bar] gebohrt drilled	DN [mm]	Da [mm]	Di [mm]	C [mm]	nL [mm]	DL [mm]	DK [mm]	 kg	VE1	VE2
9131 05E1 32	16	•	•	10/16	10	90	23	12	4	14	60	0,08	5	-
9131 06E1 32	20	•	•	10/16	15	95	28	12	4	14	65	0,09	5	-
9131 07E1 32	25	•	•	10/16	20	105	34	14	4	14	75	0,12	5	-
9131 08E1 12	32	•	•	10/16	25	115	42	15	4	14	85	0,14	5	-
9131 09E1 12	40	•	•	10/16	32	140	51	15	4	18	100	0,20	5	-
9131 10E1 12	50	•	•	10/16	40	150	62	16	4	18	110	0,24	5	-
9131 11E1 12	63	•	•	10/16	50	165	78	18	4	18	125	0,31	5	-
9131 12E1 12	75	•	•	10/16	65	185	92	19	4	18	145	0,40	5	-
9132 13E1 12	90	•		10/16	80	200	110	20	8	18	160	0,48	5	-
9132 14E1 12	110	•		10/16	100	220	133	22	8	18	180	0,60	5	-
9132 16E1 12	140	•		10/16	125	250	167	26	8	18	210	0,74	5	-
9132 17E1 12	160	•		10/16	150	285	190	28	8	22	240	1,05	5	-
9132 20E2 32	225	•		10	200	340	250	30	8	22	295	1,67	5	-
9132 21E2 32	250	•		10	250	370	277	36	8	22	325	1,80	1	-
9132 22E2 32	280	•		10	250	399	307	32	12	22	350	1,84	1	-
9132 23E2 32	315	•		10	300	450	345	34	12	22	400	2,45	1	-

-  BB = Bundbuchse • Flange adaptor socket
-  VB = Vorschweißbund • Flange adaptor spigot

## 6.01.01 Losflansche DIN-EN • Flanges DIN-EN

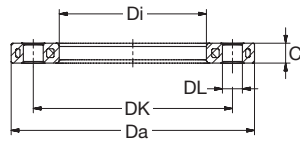

620 (73/74/75) (00/16) PP-St Losflansch DIN-EN schwarz  
PP-St Backing flange DIN-EN black

Teil / Item	d [mm]	BB	VB	PN [bar] gebohrt drilled	DN [mm]	Da [mm]	Di [mm]	C [mm]	nL [mm]	DL [mm]	DK [mm]	KG	VE1	VE2
9141 06E1 35	20	•	•	10/16	15	95	28	14	4	12	65	0,24	1	-
9141 07E1 15	25	•	•	10/16	20	105	34	14	4	14	75	0,33	1	-
9141 08E1 15	32	•	•	10/16	25	115	42	14	4	14	85	0,46	1	-
9141 09E1 15	40	•	•	10/16	32	140	51	16	4	18	100	0,67	1	-
9141 10E1 15	50	•	•	10/16	40	150	62	18	4	18	110	0,77	1	-
9141 11E1 15	63	•	•	10/16	50	165	78	18	4	18	125	0,88	1	-
9141 12E1 15	75	•	•	10/16	65	185	92	18	4	18	145	1,14	1	-
9142 13E1 15	90	•		10/16	80	200	110	18	8	18	160	0,32	1	-
9142 14E1 15	110	•		10/16	100	220	133	18	8	18	180	1,21	1	-
9142 15E1 15	125	•		10/16	100	220	149	18	8	18	180	1,08	1	-
9142 16E1 15	140	•		10/16	125	250	167	18	8	24	210	1,82	1	-
9142 17E1 15	160	•		10/16	150	285	190	22	8	24	240	2,70	1	-
9142 20E2 15	225	•		10	200	340	250	24	8	24	295	3,00	1	-
9143 13E1 15	90		•	10/16	80	200	108	18	8	18	160	1,10	1	-
9143 14E1 15	110		•	10/16	100	220	128	18	8	18	180	1,24	1	-
9143 15E1 15	125		•	10/16	100	220	135	18	8	18	180	1,21	1	-
9143 16E1 15	140		•	10/16	125	250	158	24	8	18	210	1,86	1	-
9143 17E1 15	160		•	10/16	150	285	178	24	8	22	240	2,75	1	-
9143 18E1 15	180		•	10/16	150	285	188	24	8	22	240	2,70	1	-
9143 19E2 15	200		•	10	200	340	235	24	8	22	295	3,77	1	-
9143 20E2 15	225		•	10	200	340	238	24	8	22	295	3,74	1	-
9143 21E2 15	250		•	10	250	406	288	31	12	22	350	6,04	1	-
9143 22E2 15	280		•	10	250	406	294	34	12	22	350	5,51	1	-
9143 23E2 15	315		•	10	300	460	338	34	12	22	400	9,25	1	-
9143 24E2 15	355		•	10	350	520	376	39	16	22	460	14,7	1	-
9143 25E2 15	400		•	10	400	580	430	43	16	26	515	16,8	1	-
9143 26E2 35	450		•	10	500	675	517	54	20	26	620	24,5	1	-
9143 27E2 35	500		•	10	500	675	533	54	20	26	620	24,4	1	-
9143 28E2 35	560		•	10	600	796	618	64	20	30	725	33,5	1	-
9143 29E2 35	630		•	10	600	800	645	58	20	30	725	32,4	1	-
9143 19E3 35	200		•	16	200	340	235	26	12	22	295	2,84	1	-
9143 20E3 35	225		•	16	200	340	238	26	12	22	295	2,80	1	-
9143 21E3 35	250		•	16	250	404	280	32	12	22	355	6,90	1	-
9143 22E3 35	280		•	16	250	404	290	32	12	22	355	6,80	1	-
9143 23E3 35	315		•	16	300	474	340	34	12	22	410	8,10	1	-
9143 24E3 35	355		•	16	315	530	377	50	16	26	474	16,7	1	-
9143 25E3 35	400		•	16	355	590	430	54	16	30	533	17,0	1	-

BB = Bundbuchse • Flange adaptor socket  
 VB = Vorschweißbund • Flange adaptor spigot

## 6.01.01 Losflansche DIN-EN • Flanges DIN-EN

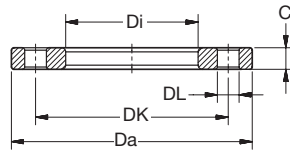

621.71.00 St Losflansch beschichtet VB DIN-EN schwarz  
 St Backing flange coated for flange adaptor spigot DIN-EN black

Teil / Item	d [mm]	PN [bar] gebohrt drilled	DN [mm]	Da [mm]	Di [mm]	C [mm]	nL [mm]	DL [mm]	DK [mm]	KG	VE1	VE2
9113 30E2 05	710	10	700	895	740	40	24	30	840	42,0	1	-
9113 31E2 05	800	10	800	1015	843	44	24	33	950	48,0	1	-
9113 32E2 05	900	10	900	1115	947	44	28	33	1050	59,0	1	-
9113 33E2 05	1000	10	1000	1230	1050	44	28	36	1160	70,0	1	-

VB = Vorschweißbund • Flange adaptor spigot

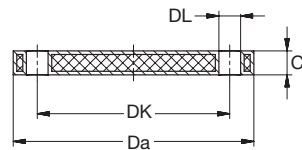

620.78.00 PP-St Blindflansch DIN-EN schwarz  
 PP-St Flange blind DIN-EN black

Teil / Item	d [mm]	PN [bar] gebohrt drilled	DN [mm]	Da [mm]	C [mm]	nL [mm]	DL [mm]	DK [mm]	KG	VE1	VE2
9144 07E1 35	25	10/16	20	105	12	4	14	75	0,38	1	-
9144 08E1 35	32	10/16	25	115	16	4	14	85	0,52	1	-
9144 09E1 35	40	10/16	32	140	16	4	18	100	0,80	1	-
9144 10E1 35	50	10/16	40	150	16	4	18	110	0,92	1	-
9144 11E1 35	63	10/16	50	165	16	4	18	125	1,16	1	-
9144 12E1 35	75	10/16	65	185	18	4	18	145	1,60	1	-
9144 13E1 35	90	10/16	80	200	20	8	18	160	2,26	1	-
9144 14E1 35	110/125	10/16	100	220	20	8	18	180	2,33	1	-
9144 16E1 35	140	10/16	125	250	24	8	18	210	3,88	1	-
9144 17E1 35	160/180	10/16	150	285	24	8	22	240	5,02	1	-
9144 19E2 35	200/225	10	200	340	24	8	22	295	7,60	1	-
9144 21E2 35	250/280	10	250	409	30	12	22	350	15,3	1	-
9144 23E2 35	315	10	300	463	34	12	22	400	25,7	1	-
9144 24E2 35	355	10	350	515	42	16	22	460	40,0	1	-
9144 25E2 35	400	10	400	574	46	16	27	515	50,4	1	-

## 6.01.02 Losflansche ANSI • Flanges ANSI

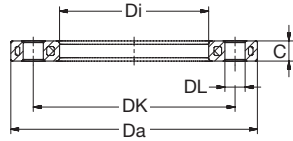

PP-St Losflansch ANSI kieselgrau  
PP-St Backing flange ANSI pebble grey

Teil / Item	d [mm]	BB	VB	PN [lbs]	DN [Inch]	Da [mm]	Di [mm]	C [mm]	nL [mm]	DL [mm]	DK [mm]		VE1	VE2
9141 06A2 38	20	•	•	150	1/2	95	28	12	4	16	60		1	60
9141 07A2 38	25	•	•	150	3/4	102	34	12	4	16	70		1	50
9141 08A2 38	32	•	•	150	1	114	42	16	4	16	79		1	30
9141 09A2 38	40	•	•	150	1 1/4	130	51	16	4	16	89		1	22
9141 10A2 38	50	•	•	150	1 1/2	133	62	16	4	16	98		1	21
9141 12A2 38	75	•	•	150	2 1/2	184	92	18	4	20	140		1	15
9141 13A2 38	90	•	•	150	3	194	111	18	4	20	152		1	15
9143 14A2 38	110/125	•*	•	150	4	229	133	18	8	20	190		1	12
9143 17A2 38	160	•	•	150	6	283	178	24	8	22	241		1	7
9143 19A2 38	200/225	•	•	150	8	345	236	24	8	22	298		1	5
9143 21A2 38	250	•	•	150	10	412	288	27	12	25	362		1	28
9143 23A2 38	315	•	•	150	12	487	338	32	12	25	432		1	20
9143 24A2 38	355	•	•	150	14	540	375,5	38	12	28,6	476	17,93	1	-
9143 25A2 38	400	•	•	150	16								1	-
9143 27A2 38	500	•	•	150	20								1	-

\*nur d110 • only d110

BB = Bundbuchse • Flange adaptor socket  
 VB = Vorschweißbund • Flange adaptor spigot

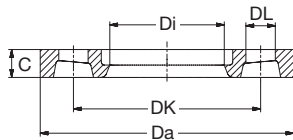

PP-GGG Losflansch ANSI Deltaflex schwarz  
PP-GGG Backing flange ANSI Deltaflex black

Teil / Item	d [mm]	BB	VB	PN [lbs]	DN [Inch]	Da [mm]	Di [mm]	C [mm]	nL [mm]	DL [mm]	DK [mm]		VE1	VE2
9151 11A2 25	63	•	•	150	2	164	78	18	4	19	121	0,80	1	-
9152 14A2 25	110	•	•	150	4							1,80	1	-
9153 13A2 25	90	•	•	150	3	196	108	19	4	19	153	1,00	1	-
9153 14A2 25	110	•	•	150	4	237	128	25	8	19	191	1,80	1	-
9153 17A2 25	160	•	•	150	6	297	178	30	8	22	242	3,30	1	-
9153 18A2 25	180	•	•	150	6	297	188	30	8	22	241,5	3,20	1	-
9153 19A2 25	200/225	•	•	150	8	354	238	34	8	22	299	5,10	1	-
9153 21A2 25	250	•	•	150	10	425	288	38	12	26	362	6,90	1	-
9153 23A2 25	315	•	•	150	12	497	338	51	12	26	432	12,8	1	-

BB = Bundbuchse • Flange adaptor socket  
 VB = Vorschweißbund • Flange adaptor spigot

## 6.01.02 Losflansche ANSI • Flanges ANSI

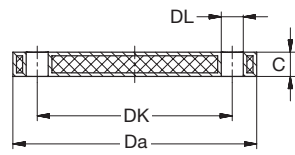

PP-St Blindflansch ANSI kieselgrau

PP-St Flange blind ANSI pebble grey

Teil / Item	d [mm]	PN [lbs]	DN [Inch]	Da [mm]	C [mm]	nL [mm]	DL [mm]	DK [mm]	KG	VE1	VE2
9144 06A2 38	20	150	1/2	95	12	4	16	60	1	60	
9144 07A2 38	25	150	3/4	102	12	4	16	70	1	40	
9144 08A2 38	32	150	1	114	16	4	16	79	1	30	
9144 09A2 38	40	150	1 1/4	130	16	4	16	89	1	20	
9144 10A2 38	50	150	1 1/2	133	16	4	16	98	1	15	
9144 11A2 38	63	150	2	162	18	4	20	121	1	14	
9144 12A2 38	75	150	2 1/2	181	18	4	20	140	1	15	
9144 13A2 38	90	150	3	194	18	4	20	152	1	10	
9144 14A2 38	110	150	4	229	18	8	20	190	1	10	
9144 17A2 38	160	150	6	283	24	8	22	241	1	5	
9144 19A2 38	200	150	8	345	24	8	22	298	1	5	
9144 21A2 38	250	150	10	412	27	12	25	362	1	-	
9144 23A2 38	315	150	12	487	34	12	25	432	1	-	

**PE100 Sonder-Flanschverbindung lang**

**PE100 Special flange connection long**

**Ausführung**

Langes Schweißende; für Heizelement-Stumpf-Schweißen und E-Muffen-Schweißen geeignet. Gebohrt nach DIN EN 1092-1. Standardmäßig mit EPDM-Runddichtring, SDR11/17 und PN10/16.

Mit kunststoffbeschichtetem Sphäroguss- oder Stahlflansch. Ausführung abhängig von der SDR-Klasse und DN/D-Kombination.

**Optional**

Flansche aus Edelstahl; Flansche aus verzinktem Stahl; flachdichtend ohne Nut und ohne O-Ring; PN25 gebohrt; mit Langloch.

Für Gasleitungen mit glatter Dichtfläche oder NBR-Dichtung lieferbar.

**Anwendung**

Direkter Anschluss an Armaturen ohne Reduzierung der Nennweite (DN).

**Besonderheiten**

- Besonders stabil
- Strömungsgünstig
- Reduzierter Totraum
- Integrierte O-Ring-Dichtung
- Klappe der Armatur ist frei beweglich

**Type**

Long welding end; for the use of butt-welding electrofusion socket-welding. Drilled according to DIN EN 1092-1. By default inclusive EPDM-O-Ring, SDR11/17 and PN10/16.

With ductile cast iron or steel backing rings, plastic coated. Type depending on the SDR-Class and on the combination of DN/D.

**Optional**

Stainless steel backing rings; hot dipped galvanized backing rings; flat sealing surface without flute or O-Ring; PN25 drilled; with slotted holes.

Available for gas pipes with flat surface or NBR-Gaskets.

**Application**

For direct connection to valves according to nominal diameter (DN).

**Special features**

- Extra stable
- Streamlined
- Reduced dead space
- Integrated O-ring seal
- Disc of the valve is free to move

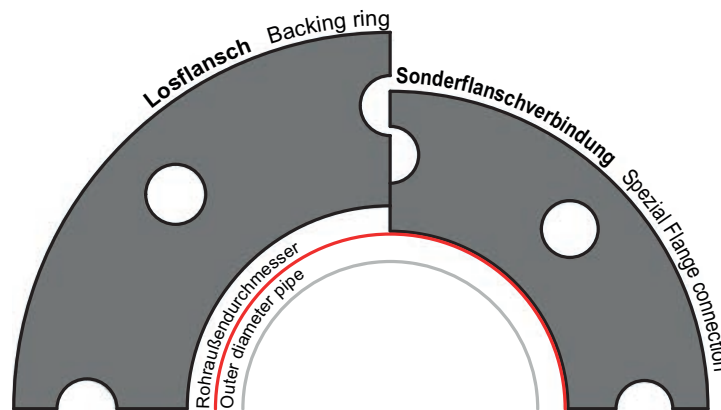

25.75.01.103 PE100 Sonder-Flanschverbindung lang **SDR11** schwarz  
 PE100 Special flange connection long **SDR11** black

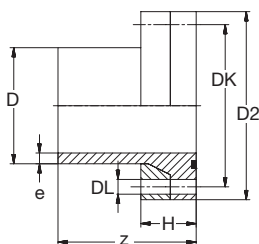

Teil / Item	D [mm]	PN gebohrt drilled	DN [mm]	e [mm]	D2 [mm]	Z [mm]	H [mm]	nL [mm]	DL [mm]	DK [mm]			VE1	VE2
9115 13E1 39	90	10/16	65	8,2	185	150	40	4	18	145	M16	3,50	1	-
9115 14E1 39	110	10/16	80	10,0	200	155	40	8	18	160	M16	4,50	1	-
9115 16E1 39	140	10/16	100	12,7	220	180	45	8	18	180	M16	5,00	1	-
9115 17E1 39	160	10/16	125	14,6	250	190	45	8	18	210	M16	6,50	1	-
9115 18E1 39	180	10/16	125	16,4	250	195	45	8	18	210	M16	6,50	1	-
9115 19E1 39	200	10/16	150	18,2	285	205	50	8	22	240	M20	8,00	1	-
9115 21E3 39	250	16	200	22,8	340	245	65	12	22	295	M20	13,0	1	-
9115 23E3 39	315	16	250	28,7	405	275	65	12	26	355	M24	20,0	1	-
9115 24E3 39	355	16	300	32,3	460	275	65	12	26	410	M24	26,0	1	-
9115 25E3 39	400	16	350	36,4	520	330	95	16	26	470	M24	39,0	1	-
9115 26E3 39	450	16	400	41,1	580	340	105	16	30	525	M27	52,5	1	-
9115 27E3 39	500	16	500	45,4	565	600	92	16	30	525	M27	63,5	1	-
9115 28E3 39	560	16	500	51,0	715	395	105	20	33	650	M30	83,0	1	-
9115 29E3 39	630	16	500	57,2	715	255	105	20	33	650	M30	95,5	1	-
9115 21E2 39	250	10	200	22,8	340	240	60	8	22	295	M20	12,0	1	-
9115 23E2 39	315	10	250	28,7	395	270	60	12	22	350	M20	17,0	1	-
9115 24E2 39	355	10	300	32,3	445	270	60	12	22	400	M20	22,0	1	-
9115 25E2 39	400	10	350	36,4	505	325	90	16	22	460	M20	30,0	1	-
9115 26E2 39	450	10	400	41,1	565	335	100	16	26	515	M24	39,0	1	-
9115 27E2 39	500	10	400	45,4	565	590	81	16	26	515	M24	50,0	1	-
9115 28E2 39	560	10	500	51,0	670	370	100	20	26	620	M24	58,0	1	-
9115 29E2 39	630	10	500	57,2	670	255	100	20	26	620	M24	117,0	1	-

PE100 Sonder-Flanschverbindung lang **SDR17** schwarz  
 PE100 Special flange connection long **SDR17** black

Teil / Item	D [mm]	PN gebohrt drilled	DN [mm]	e [mm]	D2 [mm]	Z [mm]	H [mm]	nL [mm]	DL [mm]	DK [mm]			VE1	VE2
9116 13E1 39	90	10/16	65	8,2	185	150	40	4	18	145	M16	3,50	1	-
9116 14E1 39	110	10/16	80	10,0	200	155	40	8	18	160	M16	4,50	1	-
9116 16E1 39	140	10/16	100	12,7	220	180	45	8	18	180	M16	5,00	1	-
9116 17E1 39	160	10/16	125	14,6	250	190	45	8	18	210	M16	6,50	1	-
9116 18E1 39	180	10/16	125	16,4	250	195	45	8	18	210	M16	6,50	1	-
9116 19E1 39	200	10/16	150	18,2	285	205	50	8	22	240	M20	8,00	1	-
9116 21E3 39	250	16	200	22,8	268	350	64	12	22	295	M20	13,0	1	-
9116 23E3 39	315	16	250	28,7	315	380	72	12	26	355	M24	20,0	1	-
9116 24E3 39	355	16	300	32,3	275	360	74	12	26	410	M24	26,0	1	-
9116 25E3 39	400	16	350	36,4	380	430	89	16	26	470	M24	39,0	1	-
9116 26E3 39	450	16	400	41,1	560	430	92	16	30	525	M27	52,5	1	-
9116 27E3 39	500	16	500	45,4	565	600	92	16	30	525	M27	63,5	1	-
9116 28E3 39	560	16	500	51,0	400	440	98	20	33	650	M30	83,0	1	-
9116 29E3 39	630	16	500	57,2	610	620	98	20	33	650	M30	95,5	1	-
9116 21E2 39	250	10	200	22,8	340	240	60	8	22	295	M20	12,0	1	-
9116 23E2 39	315	10	250	28,7	395	270	60	12	22	350	M20	17,0	1	-
9116 24E2 39	355	10	300	32,3	445	270	60	12	22	400	M20	22,0	1	-
9116 25E2 39	400	10	350	36,4	505	325	90	16	22	460	M20	30,0	1	-
9116 26E2 39	450	10	400	41,1	565	335	100	16	26	515	M24	39,0	1	-
9116 27E2 39	500	10	400	45,4	565	570	81	16	26	515	M24	50,0	1	-
9116 28E2 39	560	10	500	51,0	670	370	100	20	26	620	M24	58,0	1	-
9116 29E2 39	630	10	500	57,2	670	255	100	20	26	620	M24	117,0	1	-

6.02.01 Runddichtringe • O-Ring-gaskets

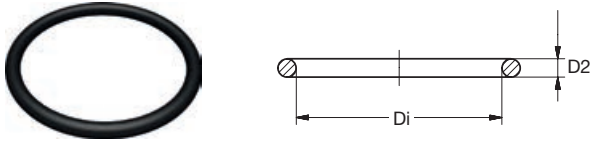

Runddichtring für Bundbuchsen mit O-Ring-Kammer schwarz  
O-Ring gasket for flange adaptor socket with O-Ring chamber black

Teil / Item EPDM	Teil / Item FKM (FPM)	d [mm]	Di [mm]	D2 [mm]	KG	VE1	VE2
Wasser/water							
9201 05R1 35	9201 05R3 35	16	18,6	3,53	0,001	10	-
9201 06R1 35	9201 06R3 35	20	23,3	3,53	0,001	10	-
9201 07R1 35	9201 07R3 35	25	28,1	3,53	0,002	10	-
9201 08R1 35	9201 08R3 35	32	36,0	3,53	0,003	10	-
9201 09R1 35	9201 09R3 35	40	43,9	3,53	0,004	10	-
9201 10R1 35	9201 10R3 35	50	53,4	5,33	0,01	10	-
9201 11R1 35	9201 11R3 35	63	69,3	5,33	0,01	10	-
9201 12R1 35	9201 12R3 35	75	81,9	5,33	0,01	10	-
9201 13R1 35	9201 13R3 35	90	101,0	5,33	0,01	10	-
9201 14R1 35	9201 14R3 35	110	120,0	6,99	0,03	10	-
9201 16R1 35	9201 16R3 35	140	151,7	6,99	0,06	10	-
9201 17R1 35	9201 17R3 35	160	177,1	6,99	0,07	10	-
9201 20R1 35	9201 20R3 35	225	240,7	6,99	0,08	10	-

Runddichtring für Verschraubungen schwarz Runddichtring  
O-Ring gasket for unions black

Teil / Item EPDM	Teil / Item FKM (FPM)	G [Inch]	Di [mm]	D2 [mm]	KG	VE1	VE2
Wasser/water							
9205 44R1 35	9205 44R3 35	5/8	12,37	2,62	0,001	10	-
9205 45R1 35	9205 45R3 35	3/4	15,55	2,62	0,001	10	-
9205 46R1 35	9205 46R3 35	1	20,22	3,53	0,001	10	-
9201 07R1 35	9201 07R3 35	1 1/4	28,10	3,53	0,002	10	-
9205 48R1 35	9205 48R3 35	1 1/2	32,92	3,53	0,002	10	-
9205 50R1 35	9205 50R3 35	2	40,64	5,33	0,003	10	-
9205 51R1 35	9205 51R3 35	2 1/4	47,00	5,33	0,004	10	-
9205 54R1 35	9205 54R3 35	2 3/4	59,70	5,33	0,005	10	-
9205 56R1 35	9205 56R3 35	3 1/2	75,56	5,33	0,01	10	-
9205 57R1 35	9205 57R3 35	4	91,45	5,33	0,01	10	-
9205 58R1 35	9205 58R3 35	5	113,66	5,33	0,01	10	-

6.02.02 Flachdichtringe • Flat-gaskets

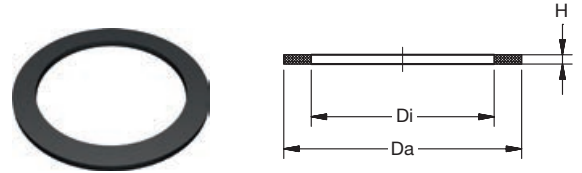

Flachdichtring für Bundbuchsen schwarz  
Gasket flat for flange adaptor socket black

Teil / Item EPDM	d [mm]	Da [mm]	Di [mm]	H [mm]	KG	VE1	VE2
Wasser/water							
9201 05F1 35	16	27	16	2	0,001	10	-
9201 06F1 35	20	32	20	2	0,001	10	-
9201 07F1 35	25	39	25	2	0,002	10	-
9201 08F1 35	32	48	32	2	0,003	10	-
9201 09F1 35	40	59	40	3	0,004	10	-
9201 10F1 35	50	71	50	3	0,01	10	-
9201 11F1 35	63	88	63	3	0,01	10	-
9201 12F1 35	75	104	75	3	0,01	10	-
9201 13F1 35	90	123	90	3	0,02	10	-
9201 14F1 35	110	148	110	4	0,03	10	-
9201 16F1 35	140	186	140	4	0,05	10	-
9201 17F1 35	160	211	160	4	0,07	10	-
9201 20F1 35	225	272	225	4	0,15	10	-

Flachdichtring für Verschraubungen schwarz  
Gasket flat for unions black

Teil / Item EPDM	G [Inch]	Da [mm]	Di [mm]	H [mm]	KG	VE1	VE2
Wasser/water							
9205 45F1 35	3/4	24	17	3	0,001	10	-
9205 46F1 35	1	30	21	3	0,002	10	-
9205 47F1 35	1 1/4	38	27	3	0,004	10	-
9205 48F1 35	1 1/2	44	32	3	0,004	10	-
9205 49F1 35	1 3/4	50	40	3	0,01	10	-
9205 50F1 35	2	55	42	3	0,01	10	-
9205 51F1 35	2 1/4	62	46	3	0,01	10	-
9205 52F1 35	2 3/8	66	52	3	0,01	10	-
9205 54F1 35	2 3/4 *	78	60	3	0,01	10	-
9205 84F1 35	2 3/4 **	78	63	3	0,01	10	-
9205 56F1 35	3 1/2	97	75	3	0,01	10	-
9205 57F1 35	4	110	88	3	0,02	10	-
9205 58F1 35	5	135	110	3	0,02	10	-

\* PVC-U/PE100

\*\* PP

## 6.02.03 Flachdichtringe mit Stahleinlage • Flat-Gaskets with steel-inlay

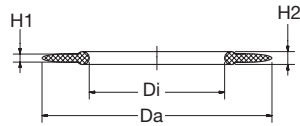

Flachdichtring mit Stahleinlage für **Bundbuchsen** gerillt schwarz  
Gasket ring flat with steel-inlay for **flange adaptor socket grooved** black

Teil / Item	Teil / Item	d	Da	Di	H1/H2	KG	VE1	VE2
EPDM	NBR	[mm]	[mm]	[mm]	[mm]			
Wasser/water	Gas/gas							
9202 05F1 35	9202 05F2 35	16	46	16	3/4	0,01	10	-
9202 06F1 35	9202 06F2 35	20	51	20	3/4	0,01	10	-
9202 07F1 35	9202 07F2 35	25	61	25	3/4	0,01	10	-
9202 08F1 35	9202 08F2 35	32	71	32	3/4	0,02	10	-
9202 09F1 35	9202 09F2 35	40	82	40	3/4	0,02	10	-
9202 10F1 35	9202 10F2 35	50	92	50	3/4	0,02	10	-
9202 11F1 35	9202 11F2 35	63	107	63	4/5	0,04	10	-
9202 12F1 35	9202 12F2 35	75	127	75	4/5	0,05	10	-
9202 13F1 35	9202 13F2 35	90	142	90	4/5	0,06	10	-
9202 14F1 35	9202 14F2 35	110	162	110	5/6	0,09	10	-
9202 15F1 35	9202 15F2 35	125	162	105	5/6	0,12	10	-
9202 16F1 35	9202 16F2 35	140	192	140	5/6	0,11	10	-
9202 17F1 35	9202 17F2 35	160	218	160	6/8	0,15	10	-
9202 19F1 35	9202 19F2 35	200	273	200	6/8	0,26	10	-
9202 20F1 35	9202 20F2 35	225	273	225	6/8	0,18	10	-
9202 21F1 35	9202 21F2 35	250	328	250	6/8	0,42	10	-
9202 22F1 35	9202 22F2 35	280	328	280	6/8	0,21	10	-
9202 23F1 35	9202 23F2 35	315	378	315	6/8	0,34	10	-

Flachdichtring mit Stahleinlage für **V-Bunde SDR11** gerillt + flach schwarz  
Gasket ring flat with steel-inlay for **flange adaptor socket SDR11** grooved + flat black

Teil / Item	Teil / Item	D	Da	Di	H1/H2	KG	VE1	VE2
EPDM	NBR	[mm]	[mm]	[mm]	[mm]			
Wasser/water	Gas/gas							
9203 07F1 35	9203 07F2 35	25	61	22	3/4	0,01	10	-
9203 08F1 35	9203 08F2 35	32	71	28	3/4	0,02	10	-
9203 09F1 35	9203 09F2 35	40	82	34	3/4	0,03	10	-
9203 10F1 35	9203 10F2 35	50	92	42	3/4	0,03	10	-
9203 11F1 35	9203 11F2 35	63	107	53	4/5	0,05	10	-
9203 12F1 35	9203 12F2 35	75	127	63	4/5	0,06	10	-
9203 13F1 35	9203 13F2 35	90	152	76	4/5	0,07	10	-
9203 14F1 35	9203 14F2 35	110	162	93	5/6	0,12	10	-
9203 15F1 35	9203 15F2 35	125	162	105	5/6	0,11	10	-
9203 16F1 35	9203 16F2 35	140	192	117	5/6	0,15	10	-
9203 17F1 35	9203 17F2 35	160	218	135	6/8	0,21	10	-
9203 18F1 35	9203 18F2 35	180	218	151	6/8	0,23	10	-
9203 19F1 35	9203 19F2 35	200	273	168	6/8	0,41	10	-
9203 20F1 35	9203 20F2 35	225	273	188	6/8	0,39	10	-
9203 21F1 35	9203 21F2 35	250	328	208	6/8	0,54	10	-
9203 22F1 35	9203 22F2 35	280	328	233	6/8	0,50	10	-
9203 23F1 35	9203 23F2 35	315	378	262	6/8	0,06	10	-
9203 24F1 35	9203 24F2 35	355	435	294	6/8		10	-
9203 25F1 35	9203 25F2 35	400	489	331	6/8		10	-
9203 26F1 35	9203 26F2 35	450	594	372	7/10		10	-
9203 27F1 35	9203 27F2 35	500	594	413	7/10		10	-
9203 28F1 35	9203 28F2 35	560	695	451	7/10		10	-
9203 29F1 35	9203 29F2 35	630	695	507	7/10		10	-

Flachdichtring mit Stahleinlage für **V-Bunde SDR17** gerillt + flach schwarz  
Gasket ring flat with steel-inlay for **flange adaptor socket SDR17** grooved + flat black

Teil / Item	Teil / Item	D	Da	Di	H1/H2	KG	VE1	VE2
EPDM	NBR	[mm]	[mm]	[mm]	[mm]			
Wasser/water	Gas/gas							
9204 12F1 35	9204 12F2 35	75	127	69	4/5	0,06	10	-
9204 13F1 35	9204 13F2 35	90	142	84	4/5	0,07	10	-
9204 14F1 35	9204 14F2 35	110	162	100	5/6	0,11	10	-
9204 15F1 35	9204 15F2 35	125	162	114	5/6	0,09	10	-
9204 16F1 35	9204 16F2 35	140	192	127	5/6	0,12	10	-
9204 17F1 35	9204 17F2 35	160	218	146	6/8	0,24	10	-
9204 18F1 35	9204 18F2 35	180	218	164	6/8	0,15	10	-
9204 19F1 35	9204 19F2 35	200	273	181	6/8	0,39	10	-
9204 20F1 35	9204 20F2 35	225	273	203	6/8	0,26	10	-
9204 21F1 35	9204 21F2 35	250	328	226	6/8	0,53	10	-
9204 22F1 35	9204 22F2 35	280	328	252	6/8	0,41	10	-
9204 23F1 35	9204 23F2 35	315	378	283	6/8	0,77	10	-
9204 24F1 35	9204 24F2 35	355	435	319	6/8	0,77	10	-
9204 25F1 35	9204 25F2 35	400	489	359	6/8		10	-
9204 26F1 35	9204 26F2 35	450	594	403	7/10		10	-
9204 27F1 35	9204 27F2 35	500	594	447	7/10		10	-
9204 28F1 35	9204 28F2 35	560	695	494	7/10		10	-
9204 29F1 35	9204 29F2 35	630	695	555	7/10		10	-

## 6.03 Clipse + Schellen • Clips + Clamps

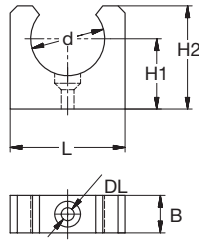

65.00.114 Rohrclip schwarz  
Pipe clip black

Teil / Item	d [mm]	L [mm]	B [mm]	H1 [mm]	H2 [mm]	DL [mm]	nL [mm]	KG	VE1	VE2
9301 0500 35	16	32	16	24	32	5	1	0,006	10	-
9301 0600 15	20	32	16	25	34	5	1	0,008	10	-
9301 0700 15	25	41	17	26	35	6	1	0,011	10	-
9301 0800 15	32	49	16	30	44	6	1	0,016	10	-

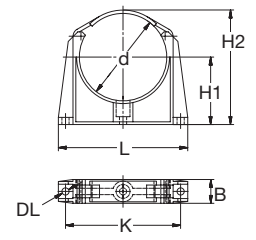
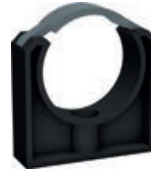

65.00.115 Rohrclip mit Bügel schwarz  
Pipe clip with bracket black

Teil / Item	d [mm]	L [mm]	B [mm]	H1 [mm]	H2 [mm]	K [mm]	DL [mm]	nL [mm]	KG	VE1	VE2
9301 090B 35	40	58	25	43	68	-	7	1	0,03	10	-
9301 100B 35	50	69	25	47	77	-	7	1	0,03	10	-
9301 110B 35	63	84	25	57	93	-	9	1	0,04	10	-
9301 120B 35	75	125	30	64	107	109	9	3	0,09	10	-
9301 130B 35	90	143	30	73	124	125	9	3	0,11	10	-
9301 140B 35	110	163	30	85	146	145	9	3	0,14	10	-
9301 150B 35	125	183	39	117	187	165	9	3	0,23	10	-
9301 160B 35	140	199	40	132	207	181	9	3	0,28	10	-
9301 170B 35	160	220	40	150	235	202	9	3	0,33	10	-

## 6.03 Clipse + Schellen • Clips + Clamps

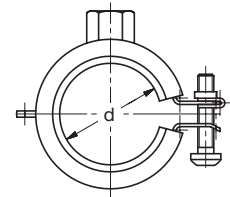
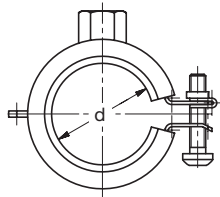

8500 Rohrschelle STANDARD mit Gummieinlage **grün**  
Pipe clamp STANDARD with rubber insert **green**

Teil / Item	d [mm]	Größe/Size [mm]	Schrauben Screws	Anschluß Connection	KG	VE1	VE2
9302 0500 31	16	15 - 19	1	M8	0,046	10	100
9302 0600 31	20	21 - 23	1	M8	0,052	10	100
9302 0700 31	25	26 - 28	1	M8	0,060	10	100
9302 0800 31	32	32 - 35	1	M8	0,064	10	75
9302 0900 31	40	40 - 43	1	M8	0,08	10	50
9302 1000 31	50	48 - 53	2	M8	0,11	10	50
9302 1100 31	63	63 - 67	1	M8/10	0,12	10	50
9302 1200 31	75	75 - 80	2	M8/10	0,14	10	25
9302 1300 31	90	89 - 91	2	M8/10	0,19	10	25

8500 Rohrschelle STANDARD mit Gummieinlage **schwarz**  
Pipe clamp STANDARD with rubber insert **black**

Teil / Item	d [mm]	Größe/Size [mm]	Schrauben Screws	Anschluß Connection	KG	VE1	VE2
9302 1400 35	110	108 - 116	2	M8/10	0,3	10	25
9302 1500 35	125	121 - 127	2	M8/10	0,33	10	25
9302 1700 35	160	160	2	M8/10	0,35	10	-
9302 1900 35	200	200	2	M8/10	0,37	1	-
9302 2100 35	250	250	2	M8/10	0,52	1	-

Für Kaltwasseranwendungen • For cold-water applications.  
Nicht für Polypropylen • Not for Polypropylene

### Rohrschelle SPEZIAL mit Gummieinlage grau Pipe clamp SPECIAL with rubber inlay grey

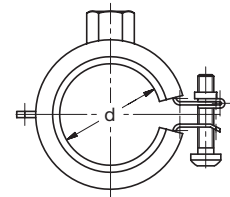

#### Ausführung

Speziell für PP-Leitungssysteme entwickelte Schelle, die in ihrem Durchmesser perfekt auf die Außendurchmesser der B-R Röhre abgestimmt ist und somit optimal die Funktion als Gleit- und Festpunktschelle erfüllt. Die Umstellung erfolgt denkbar einfach durch herausnehmen oder hinzufügen von Distanzscheiben.  
Weichmacherfrei, so dass keine Einflüsse gegenüber dem Kunststoffrohr auftreten.

#### Anwendung

Geeignet für Normalrohre, Röhre mit Faser-Mittelschicht und Röhre mit Aluminium-Außenschicht (STABITEC).  
Für Kalt- und Warmwasseranwendungen.

#### Type

Specially designed for PP pipe systems. The diameter is perfectly matched to the outer diameters of the B-R pipes and therefore optimally fulfills the function as a sliding and fixed point clamp. The conversion is easily made by removing or adding spacers.  
Plasticizer-free, so that no influences occur against the plastic tube.

#### Application

Useable for normal pipes, pipes with fiber-layer and pipes with outer Aluminium-layer (STABITEC).  
For cold- and hot-water applications.

Rohrschelle PP-SPEZIAL mit Gummieinlage **grau**  
Pipe clamp PP-SPECIAL with rubber insert **grey**

Teil / Item	d [mm]	Schrauben Screws	Anschluß Connection	KG	VE1	VE2
9302 0500 22	16	2	M8/10	0,046	10	-
9302 0600 22	20	2	M8/10	0,052	10	-
9302 0700 22	25	2	M8/10	0,060	10	-
9302 0800 22	32	2	M8/10	0,064	10	-
9302 0900 22	40	2	M8/10	0,080	10	-
9302 1000 22	50	2	M8/10	0,11	10	-
9302 1100 22	63	2	M8/10	0,12	10	-
9302 1200 22	75	2	M8/10	0,14	10	-
9302 1300 22	90	2	M8/10	0,19	10	-
9302 1400 22	110	2	M8/10	0,30	10	-
9302 1500 22	125	2	M8/10	0,33	10	-

## 6.04 Montagematerial • Mounting material

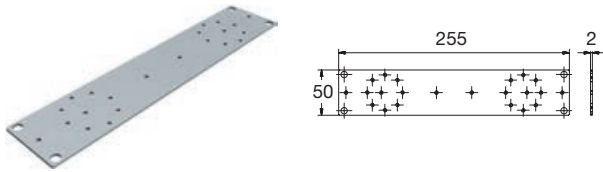

8502 Montageplatte Armaturen St-verzinkt  
Mounting plate valves galvanized steel

Teil / Item	L [mm]	B [mm]	H [mm]	KG	VE1	VE2
9401 0001 09	255	50	2	0,18		

Für Armaturen-Stichmaße 76, 100, 153 und 200mm.  
For valve tap measurements 76, 100, 153 and 200mm.

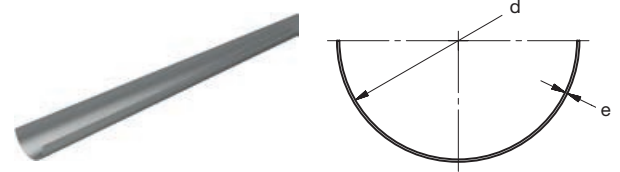

8501 Tragschale für Rohre St-verzinkt  
Support semi-tube for pipes galvanized steel

Teil / Item	d [mm]	e [mm]	L [m]	KG	VE1	VE2
9403 0730 09	25 *	0,6	3	0,60	1	-
9403 0830 09	32	0,6	3	0,77	1	-
9403 0930 09	40	0,6	3	0,95	1	-
9403 1030 09	50	0,6	3	1,14	1	-
9403 1130 09	63	0,6	3	1,50	1	-
9403 1230 09	75	0,6	3	1,80	1	-
9403 1330 09	90	0,6	3	2,05	1	-
9403 1430 09	110	0,6	3	2,35	1	-

\* Für Rohre D16-25 • for pipes D16-25.

Optische Mängel sind durch unsachgemäße Lagerung nicht zu vermeiden.  
Visual defects can not be avoided by incorrect storage.

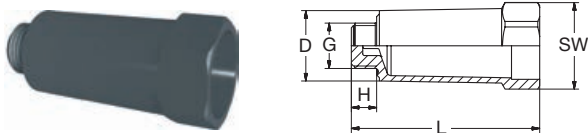

9900 Abpresszapfen AG-zyl mit NBR-Runddichtring  
Wall inlet plug male-thread-cyl with NBR-O-Ring gasket

Teil / Item	G [Inch]	grau grey	blau Blue	rot red	D [mm]	L [mm]	H [mm]	SW [mm]	KG	VE1	VE2
9402 0001 12	3/8	•			29	87	10	32	0,038	10	-
9402 0002 12	1/2	•			33	87	10	36	0,037	10	-
9402 0003 12	3/4	•			40	91	14	41	0,060	10	-
9402 0004 12	1/2	•			33	87	10	36	0,036	10	-
9402 0005 12	3/4	•			40	91	14	41	0,050	10	-
9402 0006 12	1/2	•			33	87	10	36	0,035	10	-
9402 0007 12	3/4	•			40	91	14	41	0,050	10	-

Ersatzdichtung • Replacement gasket

9402 0008 05	3/8	O-Ring NBR D15 x 3,0							0,001	10	-
9402 0009 05	1/2	O-Ring NBR D19,2 x 3,0							0,001	10	-
9402 0010 05	3/4	O-Ring NBR D25 x 3,0							0,002	10	-

**6.05.01 Schneiden • Cutting**
**HST Rohrabschneider**
**HST Pipe cutter**

**Beschreibung**

Alle Rohrabschneider bestechen durch höchste Stabilität und Servicefreundlichkeit. Sie verfügen über einen im Gehäuse integrierten, herausnehmbaren Entgrater und ihr ergonomisch optimierter Handgriff sorgt für einfache Bedienbarkeit.

**Merkmale**

- Gehärtete PTFE beschichtetes Schneidrad
- „Made in Solingen/Germany“
- Hochfestes Gehäuse aus Aluminium Druckguss
- Im Gehäuse integrierter Entgrater

**Description**

All pipe cutters are characterized by the highest stability and serviceability. They have a removable deburrer integrated in the housing and their ergonomically optimized handle ensures easy operation.

**Features**

- Cured PTFE coated cutting wheel
- „Made in Solingen / Germany“
- High-strength aluminum die-cast body
- Integrated deburrer in the housing

Technische Änderungen vorbehalten • Specifications subject to change without notice.

Teil / Item	Beschreibung	Description	KG	VE1	VE2
9501 0009 30	HST Rohrabschneider weiß Größe 1, 6-76mm für Wandstärken bis 8,6mm, mit integriertem Entgrater	HST Pipe cutter white size 1, 6-76mm for wall thicknesses up to - 8,6mm, with integrated deburring tool	0,90	1	-
9501 0010 30	HST Rohrabschneider weiß Größe 2, 50-127mm für Wandstärken bis 19,8mm, mit integriertem Entgrater	HST Pipe cutter white size 2, 50-127mm for wall thicknesses up to - 19,8mm, with integrated deburring tool	2,70	1	-
9501 0011 30	HST Rohrabschneider weiß Größe 3, 100-170mm für Wandstärken bis 19,8mm, mit integriertem Entgrater	HST Pipe cutter white size 3, 100-170mm for wall thicknesses up to - 19,8mm, with integrated deburring tool		1	-

Teil / Item	Ersatzteile	Spare parts	KG	VE1	VE2
9501 0012 30	HST Schneidrad 30 x 6,2 für Rohrabschneider Gr.1	HST Cutting wheel 30 x 6,2 for pipe cutter size 1	0,01	1	-
9501 0013 30	HST Schneidrad 35 x 11 für Rohrabschneider Gr.2+3	HST Cutting wheel 35 x 11 for pipe cutter size 2+3	0,01	1	-
9501 0014 30	HST Schneidrad 45 x 11 für Rohrabschneider Gr.2+3	HST Cutting wheel 45 x 11 for pipe cutter size 2+3	0,01	1	-
9501 0015 30	HST Schneidrad 51 x 11 für Rohrabschneider Gr.2+3	HST Cutting wheel 51 x 11 for pipe cutter size 2+3	0,01		
9501 0016 30	HST Schneidrad 67 x 11 für Rohrabschneider Gr.2+3	HST Cutting wheel 67 x 11 for pipe cutter size 2+3	0,01	1	-
				1	-
9501 0017 30	HST Schneidrad-Ersatzbolzen für Rohrabschneider Gr.1	HST Cutting wheel replacement bolt for pipe cutter size 1	0,08		
9501 0018 30	HST Schneidrad-Ersatzbolzen für Rohrabschneider Gr.2+3	HST Cutting wheel replacement bolt for pipe cutter size 2+3	0,08	1	-
9501 0019 30	HST Ersatzentgrater für Rohrabschneider Gr.1-3	HST Replacement deburring tool for pipe cutter size 1-3	0,17	1	-



Teil / Item	Beschreibung	Description	KG	VE1	VE2
9501 0001 30	HSTCUT 35 Kunststoffrohr-Schere weiß 0-35mm	HSTCUT 35 Plastic pipe scissor white 0-35mm	0,32	1	-
9501 0002 30	HSTCUT 35 Ersatzklinge	HSTCUT 35 Replacement blade	0,15	1	-
9501 0003 30	HSTCUT 42 Kunststoffrohr-Schere weiß 0-42mm	HSTCUT 42 Plastic pipe scissor white 0-42mm	0,40	1	-
9501 0004 30	HSTCUT 42 Ersatzklinge	HSTCUT 42 Replacement blade	0,15	1	-
9501 0005 30	HSTCUT 50 Kunststoffrohr-Schere weiß 0-50mm	HSTCUT 50 Plastic pipe scissor white 0-50mm	0,51	1	-
9501 0006 30	HSTCUT 50 Ersatzklinge	HSTCUT 50 Replacement blade	0,15	1	-
9501 0007 30	HSTCUT 63 Kunststoffrohr-Schere weiß 0-63mm	HSTCUT 63 Plastic pipe scissor white 0-63mm	0,64	1	-
9501 0008 30	HSTCUT 63 Ersatzklinge	HSTCUT 63 Replacement blade	0,15	1	-



**ROLLER SmartCut**

**ROLLER Akku-SmartCut**

**Beschreibung**

Handlicher, superleichter robuster Elektro-/Akku-Rohrabschneider für Kunststoff- und Verbundrohre von D10 bis 40mm.

**Merkmale**

- Zum rechtwinkligen und schnellen Trennen von Rohren
- Superhandlich, mobil, superleicht, Gewicht nur 1,9 bzw 2,1kg in der Akkuversion.
- Einfach zu bedienen, keine Einstellarbeiten erforderlich
- Stabile, verwindungsfreie Aluminiumkonstruktion für rechtwinkligen Schnitt.
- Optimal eingestellte Trenngeschwindigkeit (130 min<sup>-1</sup>) für schnelles und ruhiges Trennen.
- Robustes wartungsfreies Getriebe, präzis kugel- und nadelgelagert, für lange Lebensdauer.
- Elektroversion: Bewährter, durchzugsstarker Gleichstrommotor 230V, 130W, mit Sicherheits-Tippschalter.
- Akkuversion: mit 10,8V Li-Ion Akku und 1,3 Ah Kapazität für extrem lange Laufzeit. Überhitzungs- und Überladeschutz. Schnell-Ladegerät für kurze Ladezeiten. Kein Memory-Effekt für maximale Akkuleistung.

**Description**

Handy, ultra light, robust (cordless) pipe cutter for plastic and composite pipes from D10 to 40mm.

**Features**

- For right-angled and fast cutting of pipes.
- Ultra handy, mobile, ultra light, drive unit only 1,9 respectively 2,1 kg for the accu-version.
- Easy to operate, no setting work necessary.
- Strong, distorsion-free aluminium structure for right angle cutting.
- Optimally set cutting speed (130 rpm) for fast, quiet cutting.
- Robust, maintenance-free gear, precision ball and needle bearing, for long life.
- 230V-version: Proven, powerful 230V 130W DC motor, with safety switch.
- Accu-version: with 10,8V Li-Ion accu and 1,3 Ah capacity for for extremely long running. Overheating and overloading protection. Rapid charger for short charging times. No memory effect for maximum battery performance.

Technische Änderungen vorbehalten • Specifications subject to change without notice.



Teil / Item	Beschreibung	Description
9501 0020 30	<b>ROLLER SmartCut - 230V Basic</b> Antriebsmaschine mit Rohrauflagen, Einmaulschlüssel SW8, ohne Schneidrad, in Tragetasche.	Drive unit with pipe rests, single open ended wrench size 8, without cutting wheel, in carrying bag.
9501 0021 30	<b>ROLLER Akku-SmartCut - 10,8V Basic</b> Antriebsmaschine mit Rohrauflagen, Akku Li-Ion 10,8V, 1,3Ah, Schnellladegerät, Einmaulschlüssel SW8, ohne Schneidrad, in Tragetasche.	Drive unit with pipe rests, Li-Ion 10,8V, 1,3Ah, rapid charger, single open ended wrench size 8, without cutting wheel, in carrying bag.
9501 0022 30	<b>ROLLER Schneidrad V</b> für Kunststoff- und Verbundrohre.	<b>ROLLER cutting wheel V</b> for plastic and multi-layer-composite-pipes.
	<b>Zubehör</b>	<b>Accessories</b>
9501 0023 30	Akku Li-Ion 10,8V, 1,3 Ah	Accu Li-Ion 10,8V, 1,3Ah
9501 0024 30	Schnellladegerät, 230V, 65W	Rapid charger, 230V, 65W
9501 0025 30	Tragetasche	Carrying bag

ZUBEHÖR



**ROLLER Disc 100**

**Beschreibung**

Kompakte, mobile Rohrtrennmaschine zum schnellen rechtwinkligen Trennen von Kunststoff- und Verbundrohren von D40 bis 110mm.

**Merkmale**

- Zum rechtwinkligen und schnellen Trennen von Rohren
- Einfach zu bedienen, keine Einstellarbeiten, kein Werkzeug erforderlich
- Stabile, verwindungsfreie Gusskonstruktion für rechtwinkligen Schnitt. Leichtes Trennen der Rohre durch speziell ausgebildetes Schneidrad.
- Mit 4 stabilen kugelgelagerten Laufrollen aus gehärtetem Präzisions-Stahlrohr für reibungsarmes drehen der zu trennenden Rohre.
- Optimal eingestellte Trenngeschwindigkeit (115 min<sup>-1</sup>) für schnelles ruhiges Trennen.
- Robustes, wartungsfreies Getriebe mit hohem Wirkungsgrad.
- Bewährter, durchzugsstarker 1200W Motor mit Sicherheits-Fußschalter.
- Geringes Gewicht, leicht tragbar, nur 16,8 kg.

**Description**

Compact, lightweight, robust pipe cutting machine for fast and right-angled cutting of plastic and composite pipes from D10 to 40mm.

**Features**

- For right-angled and fast cutting of pipes.
- Easy to operate, no setting work, no tools necessary.
- Strong, distortion-free cast structure for right angle cutting. Easy cutting of the pipes by specially designed cutter wheel.
- With 4 strong, hardened precision tubular steel running rollers for low-friction-rotation of the pipes.
- Optimally set cutting speed (115 rpm) for fast, quiet cutting.
- Robust, maintenance-free gear with high efficiency.
- Proven, powerful 1200W motor with safety foot switch.
- Low weight, easily portable, only 16,8 kg.

Technische Änderungen vorbehalten • Specifications subject to change without notice.

Teil / Item	Beschreibung	Description
9501 0026 30	<b>ROLLER Disc 100 Basic</b> Antriebsmaschine mit Laufrollen aus gehärtetem Präzisions-Stahlrohr, Sicherheits-Fußschalter, Ringschlüssel, ohne Schneidrad.	Drive unit with with running rollers of hardened precision tubular steel, safety foot switch, ring spanner, without cutting wheel.
9501 0028 30	<b>ROLLER Schneidrad V, s 10</b> für Kunststoff- und Verbundrohre, Wanddicke s ≤ 10mm.	<b>ROLLER cutting wheel V, s 10</b> for plastic and multi-layer-composite-pipes, wall thickness s ≤ 10mm.



**ROLLER Disc 225**

**Beschreibung**

Kompakte, mobile Rohrtrennmaschine zum schnellen rechtwinkligen Trennen von Kunststoff- und Verbundrohren von D40 bis 225mm.

**Merkmale**

- Zum rechtwinkligen und schnellen Trennen von Rohren
- Einfach zu bedienen, keine Einstellarbeiten, kein Werkzeug erforderlich
- Stabile, verwindungsfreie Gusskonstruktion für rechtwinkligen Schnitt. Leichtes Trennen der Rohre durch speziell ausgebildetes Schneidrad.
- Mit 4 stabilen kugelgelagerten Laufrollen aus gehärtetem Präzisions-Stahlrohr für reibungsarmes drehen der zu trennenden Rohre.
- Optimal eingestellte Trenngeschwindigkeit (115 min<sup>-1</sup>) für schnelles ruhiges Trennen.
- Robustes, wartungsfreies Getriebe mit hohem Wirkungsgrad.
- Bewährter, durchzugsstarker 1200W Motor mit Sicherheits-Fußschalter.
- Kompakt, gut transportabel, nur 37 kg. Mit praktischem Fahrgestell mit zwei Gummirädern für einfachen Transport.

**Description**

Compact, lightweight, robust pipe cutting machine for fast and right-angled cutting of plastic and composite pipes from D10 to 225mm.

**Features**

- For right-angled and fast cutting of pipes.
- Easy to operate, no setting work, no tools necessary.
- Strong, distorsion-free cast structure for right angle cutting. Easy cutting of the pipes by specially designed cutter wheel.
- With 4 strong, hardened precision tubular steel running rollers for low-friction-rotation of the pipes.
- Optimally set cutting speed (115 rpm) for fast, quiet cutting.
- Robust, maintenance-free gear with high efficiency.
- Proven, powerful 1200W motor with safety foot switch.
- Compact, easily transportable, only 37 kg. With practical chassis with two rubber tyred wheels for easy transport.

Technische Änderungen vorbehalten • Specifications subject to change without notice.

Teil / Item	Beschreibung	Description
9501 0027 30	<b>ROLLER Disc 225 Basic</b> Antriebsmaschine mit Laufrollen aus gehärtetem Präzisions-Stahlrohr, Sicherheits-Fußschalter, Ringschlüssel, ohne Schneidrad, 2 Stück höhenverstellbare Rohrauflagen D100-225mm.	Drive unit with with running rollers of hardened precision tubular steel, safety foot switch, ring spanner, without cutting wheel, 2 height adjustable pipe rests D100-225mm.
9501 0028 30	<b>ROLLER Schneidrad V, s 10</b> für Kunststoff- und Verbundrohre, Wanddicke s ≤ 10mm.	<b>ROLLER cutting wheel V, s 10</b> for plastic and multi-layer-composite-pipes, wall thickness s ≤ 10mm.
9501 0029 30	<b>ROLLER Schneidrad P, s 21</b> für Kunststoff- und Verbundrohre, Wanddicke s ≤ 21mm.	<b>ROLLER cutting wheel P, s 21</b> for plastic and multi-layer-composite-pipes, wall thickness s ≤ 21mm.



Quality for Professionals



Teil / Item	Inhalt Content [ml]	Beschreibung	Description	KG	VE1	VE2
9502 0001 30	125	PVC-U/C ABS Reiniger für Rohrklebeverbindungen	PVC-U/C ABS Cleaner for pipe bonding connections	0,15	1	-
9502 0002 30	1000			0,94	1	-



Teil / Item	Inhalt Content [ml]	Beschreibung	Description	KG	VE1	VE2
9502 0003 30	1000	PE/PP/PB/PVDF Spezial-Reiniger für Kunststoff-Schweißverbindungen	PE/PP/PB/PVDF Special Cleaner for plastic welding joints	0,860	1	-



Teil / Item	Inhalt Content [St/pc]	Beschreibung	Description	KG	VE1	VE2
9502 0004 30	100	PE/PP/PB/PVDF Spezial-Reinigungstücher für Kunststoff-Schweißverbindungen	PE/PP/PB/PVDF Special Cleaning tissues for welding of plastic materials	0,330	1	-

6.05.03 Kleben • Bonding



Teil / Item	Inhalt Content [g]	Beschreibung	Description	KG	VE1	VE2
9503 0001 30	250	PVC-U Spezial-Klebstoff für zugfeste Rohrverbindungen	PVC-U Special Adhesive for (rigid) fittings and pipes	0,30	1	-
9503 0002 30	500			0,59	1	-
9503 0003 30	1000			1,13	1	-



Teil / Item	Beschreibung	Description	Für Formteile For fittings	KG	VE1	VE2
9503 0004 30	Pinsel rund Gr.4	Brush round size 4	10 - 12 mm	0,01	1	-
9503 0005 30	Pinsel rund Gr.12	Brush round size 12	16 - 32 mm	0,01	1	-
9503 0006 30	Pinsel flach Gr.25 x 3 mm	Brush flat size 25 x 3 mm	40 - 63 mm	0,01	1	-
9503 0007 30	Pinsel flach Gr.50 x 3 mm	Brush flat size 50 x 3 mm	75 - 160 mm	0,02	1	-

**Muffen-Handschweißgeräte**  
Set = mit Schweißwerkzeugen (Typ A)

**Socket hand-polywelder**  
Set = with welding tools (Typ A)



Teil / Item	Beschreibung	Description
9504 0001 30	OM 10050 ECO Set - 230V, d20-32	
9504 0002 30	OM 1045 ECO Set - 230V, d20-32 mit Ständer und Box • with support and box	
9504 0003 30	OM 1045 Set - 230V, d16-63 mit Ständer und Box • with support and box	
9004 0004 30	OM 1045 Set - <b>110V</b> , d16-63 mit Ständer und Box • with support and box	
9504 0005 30	OM 10125 - 230V bis d125 mit Ständer und Box • with support and box	

	Ersatzteile	Replacement parts
9504 0010 30	OM Heizelement 1000W	OM Heating element 1000W
9504 0011 30	OM Kunststoff-Griff	OM Plastic handle
9504 0012 30	OM Platine Temp.-Anzeige	OM Circuit Board (temperature)
9504 0013 30	OM Thermostat	OM Thermostat



8982  
Schweißwerkzeug (Muffe + Dorn)  
Teflon-beschichtet Typ-A \*  
Socket-welding tool (Socket + plug)  
Teflon-coated Type-A \*

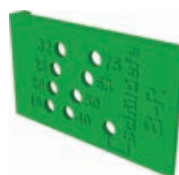

Teil / Item	d [mm]	KG	VE1	VE2
9504 0500 09	16	0,080	1	-
9504 0600 09	20	0,10	1	-
9504 0700 09	25	0,14	1	-
9504 0800 09	32	0,22	1	-
9504 0900 09	40	0,33	1	-
9504 1000 09	50	0,47	1	-
9504 1100 09	63	0,67	1	-
9504 1200 09	75	0,89	1	-
9504 1300 09	90	1,18	1	-
9504 1400 09	110	1,95	1	-
9504 1500 09	125	2,25	1	-

Teil / Item	Beschreibung	Description
9504 0020 21	Schablone Muffentiefe d16 – 75 mm	Gauge PP-socket welding depth d16 – 75mm

\* nach DVS 2208 • According to DVS 2208.

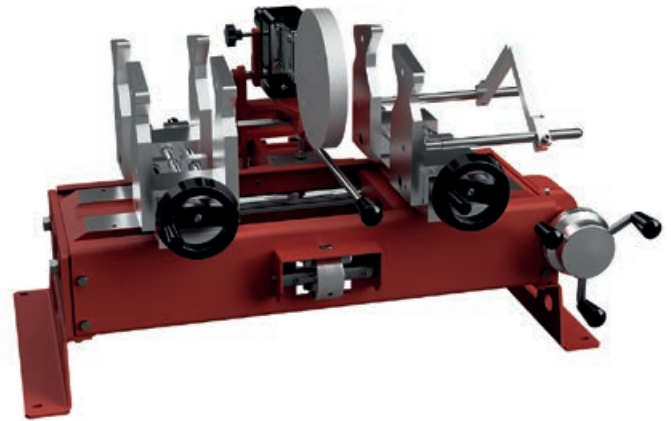

### OM-7125 Set

Muffen-Schweiß-Maschine für Polypropylen-Rohre und Formteile von 32 bis 125mm  
 Socket fusion welding machine for Polypropylene pipes and fittings from 32 – 125mm

#### Beschreibung

Heizelement-Muffen-Schweißmaschine mit beweglichen Schlitten, auf denen prismatische Klemmen montiert sind, um eine automatische Selbstzentrierung aller Arten von Rohren und Formteilen zu ermöglichen. Das Heizelement lässt sich leicht per Hand entnehmen.

Das Schweißen erfolgt halbautomatisch durch einen Federmechanismus in der Maschine. Die Maschine wird im Stahlkasten zum leichten Transport und zur Verwendung als Werkbank geliefert.

#### Merkmale

- Stahl Transportbox/Werkbank
- Halbautomatischer Federmechanismus
- Automatische Selbstzentrierung
- Teflon beschichtete Schweißbeinsätze

#### Spezifikationen

Für Rohrgrößen: D 32 – 125 mm  
 Temperatur: 50 – 300°C  
 Gesamtgewicht: 80 kg  
 Elektr. Anschluß: 230V / 50/60Hz  
 Leistung: 1,4 kW  
 Volumen: 60 x 80 x 85 cm

#### Lieferumfang

Verpackung beinhaltet Schweißmaschine, austauschbares Heizelement, Stahl-Transportbox/Werkbank, Rohrstütze, Satz Schweiß-Einsätze von 50 bis 125mm Typ A (DVS 2208).

#### Description

Socket fusion polywelder equipped with movement slides on which prismatic clamps are placed to allow an automatic self-centering of any kinds of pipes and fittings. The Polywelder can be easily extracted by hand.

Welding is made in a semi-automatic way due to a spring loading device of the machine. The machine is supplied in steel box for easy movement of the polywelder and for using as a workbench.

#### Features

- Steel box/workbench
- Semi-automatic spring mechanism
- Automatic self-centering
- Teflon plated bushes

#### Specifications

Fuses pipe sizes: D 32 – 125mm  
 Temperature: 50 – 300°C  
 Weight: 80 kg  
 Power supply: 230V / 50/60Hz  
 Power: 1,4 kW  
 Volume: 60 x 80 x 85 cm

#### Scope of delivery

Packaging includes welding machine, extractable polywelder, steel transport box/work bench, pipe support tripod, set of bushes from 50 to 125mm type A (DVS 2208).

Technische Änderungen vorbehalten • Specifications subject to change without notice.

Teil / Item	Beschreibung	Description
9504 0020 30	OM 7125 Set - 230V	
	Ersatzteile	Replacement parts
9504 0005 30	OM 10125/TF Heizelement	OM 10125/TF Heating element



### SPIDER™ 125 mit universal Einspannvorrichtung

Muffen-Verbindungs-Werkzeug für Polypropylen-Rohre von 63 bis 125mm

### SPIDER™ 125 with universal clamping

Socket fusion tool for 63mm to 125mm Polypropylene pipe

#### Beschreibung

Der SPIDER™ 125 mit Universal-Spannsystem ist die bevorzugte Ausrüstung für schnelle und genaue Muffen-Schweißungen von 63 bis 125mm Polypropylen-Rohr. Das leichte, kompakte Gerät verfügt über ein Schneckengetriebe mit Parallelenkersystem, um Rohr und Formteil gleichmäßig und kontrolliert zu bewegen. Es verfügt über ein Universal-Spannsystem, das jede Größe von Rohr oder Verbindung aufnehmen kann, wodurch die Notwendigkeit für Einsätze entfällt.

Die Eigenschaften des SPIDERS erlauben es einem einzelnen Techniker, das Rohr richtig auszurichten, zu erwärmen, zu schweißen und abzukühlen. Da der SPIDER ein nicht rückfahrendes Getriebe hat, wird während des gesamten Prozesses ein konstanter Druck beibehalten.

Der SPIDER hat sich als außergewöhnliches Werkzeug für die Durchführung von Schweißverbindungen über Kopf, vertikalen und engen Arbeitsräumen erwiesen. Für Rohrgrößen im Bereich von 63 bis 125 mm steht ein komplettes Sortiment an Heizelementen und Schweißensätzen zur Verfügung.

#### Merkmale

- Handbetrieben
- Keine Einsätze erforderlich
- Universal-Spannbackensystem passt zu allen Rohr- und Formteillfabrikaten
- Nicht rückfahrendes Getriebe, selbstsichernd
- Zwei-Punkt-Stützgriff
- Leicht und kompakt
- Selbstzentrierend
- Breite Spannbacken sorgen für Stabilität am Rohr

#### Spezifikationen

Für Rohrgrößen: D 63 - 125mm  
 Maschinengewicht: 6,8 kg (15 lbs.)  
 Maximale Hublänge: 193mm (7,6 Zoll)

#### Lieferumfang

Verpackung beinhaltet SPIDER-Maschine und Tragetasche. Heizelement und Muffen-Schweißwerkzeuge sind separat erhältlich.

#### Description

The SPIDER™ 125 with Universal Clamping system is the preferred equipment for quick and accurate socket-welding field installations from 63 to 125mm Polypropylene pipe.

The lightweight, compact device features a worm gear drive with parallel link system to bring pipe and fittings together aligned and moving under control. It features a Universal Clamping system that can accommodate any size of pipe or coupling, eliminating the need for inserts.

The features of the SPIDER allow a single technician to properly align, heat, weld and cool the pipe. Because the SPIDER is non back-driveable, constant pressure is maintained throughout the process.

The SPIDER has proven to be an exceptional tool for performing socket-weldings in overhead, vertical and tight work spaces. A full assortment of heaters and heater adapters are available for pipe sizes from 63 to 125mm range.

#### Features

- Hand-powered
- No inserts necessary
- Universal Clamping jaw system fits all pipe brands and fittings
- Non back-driveable gearing, self-locking
- Two-position support handle
- Lightweight and compact
- Self-centering
- Wide jaws provide stability on pipe

#### Specifications

Fuses pipe sizes: D 63 - 125mm  
 Machine Weight: 6,8 kg (15 lbs.)  
 Maximum Stroke Length: 193mm (7.6 inch)

#### Scope of delivery

Packaging includes SPIDER fusion machine and carrying case. Heater and other socket-welding tools sold separately.

Technische Änderungen vorbehalten • Specifications subject to change without notice.

Teil / Item 9504 0021 30



### OM-SP250 Set

Stumpf-Schweiß-Maschine 230V mit Zubehör für PE/PP-Rohre und Formteile von 90 bis 250 mm  
Butt-welding machine 230V with accessories for PE/PP-pipes and fittings from 90 to 250 mm

#### Beschreibung

Stumpf-Schweiß-Maschine für Rohre und Formteile aus PE/PP und anderen thermoplastischen Materialien. Im Set mit allen Reduzierungen.

#### Merkmale

- Basisgerät mit vier, auf einem fahrbaren Schlitten befestigte, 250 mm Spannbacken.
- Gehärtete verchromte Führungen.
- Dritter justierbarer Spannbacken.
- Leckagefreie Schnellverschlußkupplungen
- Automatische Trennung vom Heizelement
- Heizelement Teflon beschichtet und thermostatisch geregelt.
- Elektrischer Rotations-Schäler als Planhobel

#### Spezifikationen

Für Rohrgrößen: D 90 – 250 mm  
Temperatur: 50 – 300°C  
Maximaler Druck: 150 bar  
Gesamtgewicht: 167 kg  
Maximaleistung: 3kW / 230V / 50/60Hz  
Volumen: 120 x 80 x 74 cm

#### Lieferumfang

Verpackung beinhaltet Schweißmaschine, einstellbares Heizelement, elektronische Thermostat-Box, elektrischen Planhobel, Paar flexible Hydraulik-Schläuche, Stahl-Box für Heizelement und Planhobel, Reduzierungen (250-225/200/180/160/140/125/110/90) und Holz-Transportkiste.

#### Description

Butt-welding machine for pipes and fittings in PE/PP and other thermoplastic materials. As a set with all reductions.

#### Features

- Basic machine with four 250 mm main jaws arranged on a sliding frame
- Sliding hardened chromate guides
- Third adjustable jaw
- Quick hydraulic antidrop release couplings
- Automatic breakaway of thermoplate
- Heating element Teflon-coated and thermostatically controlled
- Electric rotating scraper as planing tool

#### Specifications

Fuses pipe sizes: D 90 – 250 mm  
Temperature: 50 – 300°C  
Maximum pressure: 150 bar  
Total weight: 167 kg  
Maximum power: 3kW / 230V / 50/60Hz  
Volume: 120 x 80 x 74 cm

#### Scope of delivery

Packaging includes welding machine, adjustable heating element, electronic thermostat box, electric planing tool, pair of flexible hydraulic pipes, steel box for heating element and electric planing tool, reducer brackets (250-225/200/180/160/140/125/110/90) and wooden carrying case.

Technische Änderungen vorbehalten • Specifications subject to change without notice.

Teil / Item **9505 0001 30**



### OM-SP315 Set

Stumpf-Schweiß-Maschine 230V mit Zubehör für PE/PP-Rohre und Formteile von 90 bis 315 mm  
Butt-welding machine 230V with accessories for PE/PP-pipes and fittings from 90 to 315 mm

#### Beschreibung

Stumpf-Schweiß-Maschine für Rohre und Formteile aus PE/PP und anderen thermoplastischen Materialien. Im Set mit allen Reduzierungen.

#### Merkmale

- Basisgerät mit vier, auf einem fahrbaren Schlitten befestigte, 315 mm Spannbacken.
- Gehärtete verchromte Führungen.
- Dritter justierbarer Spannbacken.
- Leckagefreie Schnellverschlußkupplungen
- Automatische Trennung vom Heizelement
- Heizelement Teflon beschichtet und thermostatisch geregelt.
- Elektrischer Rotations-Schäler als Planhobel

#### Spezifikationen

Für Rohrgrößen: D 90 – 315 mm  
Temperatur: 50 – 300°C  
Maximaler Druck: 150 bar  
Gesamtgewicht: 209 kg  
Maximaleistung: 3,8kW / 230V / 50/60Hz  
Volumen: 120 x 80 x 84 cm

#### Lieferumfang

Verpackung beinhaltet Schweißmaschine, einstellbares Heizelement, elektronische Thermostat-Box, elektrischen Planhobel, Paar flexible Hydraulik-Schläuche, Stahl-Box für Heizelement und Planhobel, Reduktionen (315-280/250 und 250-225/200/180/160/140/125/110/90) und Holz-Transportkiste.

#### Description

Butt-welding machine for pipes and fittings in PE/PP and other thermoplastic materials. As a set with all reductions.

#### Features

- Basic machine with four 315 mm main jaws arranged on a sliding frame
- Sliding hardened chromate guides
- Third adjustable jaw
- Quick hydraulic antidrop release couplings
- Automatic breakaway of thermoplate
- Heating element Teflon-coated and thermostatically controlled
- Electric rotating scraper as planing tool

#### Specifications

Fuses pipe sizes: D 90 – 315 mm  
Temperature: 50 – 300°C  
Maximum pressure: 150 bar  
Total weight: 209 kg  
Maximum power: 3,8kW / 230V / 50/60Hz  
Volume: 120 x 80 x 84 cm

#### Scope of delivery

Packaging includes welding machine, adjustable heating element, electronic thermostat box, electric planing tool, pair of flexible hydraulic pipes, steel box for heating element and electric planing tool, reducer brackets (315-280/250 and 250-225/200/180/160/140/125/110/90) and wooden carrying case.

Technische Änderungen vorbehalten • Specifications subject to change without notice.

Teil / Item **9505 0002 30**



### OM-SP500 Set

Stumpf-Schweiß-Maschine 230V mit Zubehör für PE/PP-Rohre und Formteile von 200 bis 500 mm

Butt-welding machine 230V with accessories for PE/PP-pipes and fittings from 200 to 500 mm

#### Beschreibung

Stumpf-Schweiß-Maschine für Rohre und Formteile aus PE/PP und anderen thermoplastischen Materialien. Im Set mit allen Reduzierungen.

#### Merkmale

- Basisgerät mit vier, auf einem fahrbaren Schlitten befestigte, 500 mm Spannbacken.
- Gehärtete verchromte Führungen.
- Dritter justierbarer Spannbacken.
- Leckagefreie Schnellverschlussskupplungen
- Automatische Trennung vom Heizelement
- Heizelement Teflon beschichtet und thermostatisch geregelt.
- Elektrischer Rotations-Schäler als Planhobel

#### Spezifikationen

Für Rohrgrößen: D 200 – 500 mm  
 Temperatur: 50 – 300°C  
 Maximaler Druck: 150 bar  
 Gesamtgewicht: 475 kg  
 Maximalleistung: 5,5kW / 230V / 50/60Hz  
 Volumen: 120 x 80 x 94 cm + 120 x 80 x 109 cm

#### Lieferumfang

Verpackung beinhaltet Schweißmaschine, einstellbares Heizelement, elektronische Thermostat-Box, elektrischen Planhobel, Paar flexible Hydraulik-Schläuche, Stahl-Box für Heizelement und Planhobel, Reduktionen (500-450/400/355/315 und 315-280/250) und zwei Holz-Transportkisten.

#### Description

Butt-welding machine for pipes and fittings in PE/PP and other thermoplastic materials. As a set with all reductions.

#### Features

- Basic machine with four 500 mm main jaws arranged on a sliding frame
- Sliding hardened chromate guides
- Third adjustable jaw
- Quick hydraulic antidrop release couplings
- Automatic breakaway of thermoplate
- Heating element Teflon-coated and thermostatically controlled
- Electric rotating scraper as planing tool

#### Specifications

Fuses pipe sizes: D 200 – 500 mm  
 Temperature: 50 – 300°C  
 Maximum pressure: 150 bar  
 Total weight: 475 kg  
 Maximum power: 5,5kW / 230V / 50/60Hz  
 Volume: 120 x 80 x 94 cm + 120 x 80 x 109 cm

#### Scope of delivery

Packaging includes welding machine, adjustable heating element, electronic thermostat box, electric planing tool, pair of flexible hydraulic pipes, steel box for heating element and electric planing tool, reducer brackets (500-450/400/355/315 and 315-280/250) and two wooden carrying cases.

Technische Änderungen vorbehalten • Specifications subject to change without notice.

Teil / Item 9505 0003 30



### HST EasyWeld 110

inkl. Horizontalverstellung und manuellem Planhobel  
with horizontal Adjustability and manuel planer

#### Beschreibung

Stumpf-Schweiß-Maschine zum einfachen und mobilen Stumpf-Schweißen von PE/PP-Rohren und Formteilen für alle Druckstufen von D 20 bis 110 mm. Grundmaschine inkl. Grundspannklemmen D20-110mm, montiert auf einer pulverbeschichteten Grundplatte.

#### Merkmale

- Grundspannklemmen sind beidseitig, jeweils um 15° zu verstellen.
- Grundspannklemmen verfügen über horizontale Verstellmöglichkeiten (Vorteile beim Segmentschweißen).
- Mechanischer Planhobel inkl. Horizontalverstellung und zweifach Wendemesser.
- Elektronisch geregeltes und PTFE-beschichtetes Heizelement.
- Tischhalterungen für Heizelement und optional für Hobel.
- Hochfester Stahlblech-Transportkoffer.

#### Spezifikationen

Für Rohrgrößen: D 20 – 110 mm  
Stromversorgung: 230V oder 110V  
Leistung Heizelement/Planhobel: 800/- Watt  
Gesamtgewicht: 31,9 kg  
Volumen: 500 x 450 x 350 cm  
Herstellergarantie: 12 Monate

#### Lieferumfang

Transportkiste beinhaltet Schweißmaschine, Heizelement, Planhobel, Reduzierungen (jeweils 8 St./Dimension 20/25/32/40/50/63/75/90) und Zubehör (Bedienungsanleitung, 2x Inbusschlüssel).

#### Description

Butt-welding machine for easy and mobile butt-welding of PE/PP-pipes and fittings, for all pressure ratios, from D 20 to 110 mm. Basic machine chassis featuring clamps for D20-110mm, set on powder-coated base panel.

#### Features

- Clamps on machine chassis swiveling by up to 15° degrees.
- Clamps mechanically adjustable horizontally (for more efficient placement in segmented bend applications).
- Mechanic, horizontally adjustable facing tool with two-edge useable facing blade.
- Electronically controlled, PTFE-coated heating element.
- Tabletop stands for heating element and optional for planer.
- High-spec metal transport case!

#### Specifications

Fuses pipe sizes: D 20 – 110 mm  
Power supply: 230V or 110V  
Power Heating element/Planer: 800/- Watt  
Total weight: 31,9 kg  
Volume: 500 x 450 x 350 cm  
Manufacturer warranty: 12 months

#### Scope of delivery

Transport case incl. welding machine, heating element, facing tool, reducers (set of 8 for every size D20/25/32/40/50/63/75/90) and accessories (User's manual, 2x Allen wrenches).

Technische Änderungen vorbehalten • Specifications subject to change without notice.

Teil / Item	Beschreibung	Description
9505 0020 30	HST EasyWeld 110 - 230V	
9505 0021 30	HST EasyWeld 110 - 110V	
	Optionen	Optional
9505 0026 30	Schmale Grundspannwerkzeuge rechts/links	Narrow-profile clamps RH, LH for machine chassis
9505 0027 30	Halter Vorschweißbund	Support tool for Flange adaptor spigot
9505 0029 30	Tischhalterung Planhobel	Tabletop stand for facing tool



### HST EasyWeld 110 E

inkl. Horizontalverstellung und elektrischem Planhobel  
with horizontal Adjustability and Power facing tool

#### Beschreibung

Stumpf-Schweiß-Maschine zum einfachen und mobilen Stumpf-Schweißen von PE/PP-Rohren und Formteilen für alle Druckstufen von D 20 bis 110 mm. Grundmaschine inkl. Grundspannklemmen D20-110mm, montiert auf einer pulverbeschichteten Grundplatte.

#### Merkmale

- Grundspannklemmen sind beidseitig, jeweils um 15° zu verstellen.
- Grundspannklemmen verfügen über horizontale Verstellmöglichkeiten (Vorteil beim Segmentschweißen).
- Elektrischer Planhobel inkl. Horizontalverstellung und zweifach Wendemesser.
- Elektronisch geregeltes und PTFE-beschichtetes Heizelement.
- Tischhalterungen für Heizelement und optional für Hobel.
- Hochfester Stahlblech-Transportkoffer.

#### Spezifikationen

Für Rohrgrößen: D 20 – 110 mm  
Stromversorgung: 230V oder 110V  
Leistung Heizelement/Planhobel: 800/560 Watt  
Gesamtgewicht: 40,1 kg  
Volumen: 500 x 450 x 350 cm  
Herstellergarantie: 12 Monate

#### Lieferumfang

Transportkiste beinhaltet Schweißmaschine, Heizelement, Planhobel, Reduzierungen (jeweils 8 St./Dimension 20/25/32/40/50/63/75/90) und Zubehör (Bedienungsanleitung, 2x Inbusschlüssel).

#### Description

Butt-welding machine for easy and mobile butt-welding of PE/PP-pipes and fittings, for all pressure ratios, from D 20 to 110 mm. Basic machine chassis featuring clamps for D20-110mm, set on powder-coated base panel.

#### Features

- Clamps on machine chassis swiveling by up to 15° degrees.
- Clamps mechanically adjustable horizontally (for more efficient placement in segmented bend applications).
- Electrical, horizontally adjustable facing tool with two-edge useable facing blade.
- Electronically controlled, PTFE-coated heating element.
- Tabletop stands for heating element and optional for planer.
- High-spec metal transport case

#### Specifications

Fuses pipe sizes: D 20 – 110 mm  
Power supply: 230V or 110V  
Power Heating element/Planer: 800/560 Watt  
Total weight: 40,1 kg  
Volume: 500 x 450 x 350 cm  
Manufacturer warranty: 12 months

#### Scope of delivery

Transport case incl. welding machine, heating element, facing tool, reducers (set of 8 for every size D20/25/32/40/50/63/75/90) and accessories (User's manual, 2x Allen wrenches).

Technische Änderungen vorbehalten • Specifications subject to change without notice.

Teil / Item	Beschreibung	Description
9505 0022 30	HST EasyWeld 110 E - 230V	
9505 0023 30	HST EasyWeld 110 E - 110V	
	Optionen	Optional
9505 0026 30	Schmale Grundspannwerkzeuge rechts/links	Narrow-profile clamps RH, LH for machine chassis
9505 0027 30	Halter Vorschweißbund	Support tool for Flange adaptor spigot
9505 0028 30	Vertikalverstellung	Vertical adjustability
9505 0029 30	Tischhalterung Planhobel	Tabletop stand for facing tool



### HST EasyWeld 110 T

inkl. Höhen- und Seitenverstellung und elektrischem Planhobel  
with horizontal and vertical Adjustability and Power facing tool

#### Beschreibung

Stumpf-Schweiß-Maschine zum einfachen und mobilen Stumpf-Schweißen von PE/PP-Rohren und Formteilen für alle Druckstufen von D 20 bis 110 mm. Grundmaschine inkl. Grundspannklemmen D20-110mm, montiert auf einer pulverbeschichteten Grundplatte.

#### Merkmale

- Grundspannklemmen sind beidseitig, jeweils um 15° zu verstellen.
- Grundspannklemmen verfügen über horizontale und vertikale Verstellmöglichkeiten (Vorteile beim Segmentschweißen).
- Elektrischer Planhobel inkl. Horizontalverstellung und zweifach Wendemesser.
- Elektronisch geregeltes und PTFE-beschichtetes Heizelement.
- Tischhalterungen für Heizelement und optional für Hobel.
- Hochfester Stahlblech-Transportkoffer.

#### Spezifikationen

Für Rohrgrößen: D 20 – 110 mm  
Stromversorgung: 230V oder 110V  
Leistung Heizelement/Planhobel: 800/560 Watt  
Gesamtgewicht: 40,1 kg  
Volumen: 560 x 450 x 350 cm  
Herstellergarantie: 12 Monate

#### Lieferumfang

Transportkiste beinhaltet Schweißmaschine, Heizelement, Planhobel, Reduzierungen (jeweils 8 St./Dimension 20/25/32/40/50/63/75/90) und Zubehör (Bedienungsanleitung, 2x Inbusschlüssel).

#### Description

Butt-welding machine for easy and mobile butt-welding of PE/PP-pipes and fittings, for all pressure ratios, from D 20 to 110 mm. Basic machine chassis featuring clamps for D20-110mm, set on powder-coated base panel.

#### Features

- Clamps on machine chassis swiveling by up to 15° degrees.
- Clamps mechanically adjustable horizontally and vertically (for more efficient placement in segmented bend applications).
- Electrical, horizontally adjustable facing tool with two-edge useable facing blade.
- Electronically controlled, PTFE-coated heating element.
- Tabletop stands for heating element and optional for planer.
- High-spec metal transport case

#### Specifications

Fuses pipe sizes: D 20 – 110 mm  
Power supply: 230V or 110V  
Power Heating element/Planer: 800/560 Watt  
Total weight: 40,1 kg  
Volume: 560 x 450 x 350 cm  
Manufacturer warranty: 12 months

#### Scope of delivery

Transport case incl. welding machine, heating element, facing tool, reducers (set of 8 for every size D20/25/32/40/50/63/75/90) and accessories (User's manual, 2x Allen wrenches).

Technische Änderungen vorbehalten • Specifications subject to change without notice.

Teil / Item	Beschreibung	Description
9505 0024 30	HST EasyWeld 110 T - 230V	
9505 0025 30	HST EasyWeld 110 T - 110V	
	Optionen	Optional
9505 0026 30	Schmale Grundspannwerkzeuge rechts/links	Narrow-profile clamps RH, LH for machine chassis
9505 0027 30	Halter Vorschweißbund	Support tool for Flange adaptor spigot
9505 0029 30	Tischhalterung Planhobel	Tabletop stand for facing tool



### HST-WeldControl 2.0 - 250 Set

inkl. Reduzierungen DA63 - 225

with Reducers DA63 - 225

#### Beschreibung

Stumpf-Schweiß-Maschine zum Verschweißen von Rohren und Formteilen aus PE und PP von DA 63 bis DA 250 mm, für alle SDR-Klassen.

#### Merkmale

- Automatische Berechnung aller Schweißzeiten und Druckwerte.
- Automatische Regelung der Spiegeltemperatur.
- Automatische Protokollierung von bis zu 10.000 Schweißungen.
- Dateneingabe: RFID-Transponder, Manuell, Scanner (optional).
- Systemüberwachung.
- Schweißüberwachungssystem.
- Rückverfolgbarkeit nach ISO 12176-1
- Schweißnormen: DVS, WIS, SEDIGAS, UNI, NEN.
- Datenausgabe über Druckmenü
- Sprachen: DE, EN, FR, BG, CS, ZH, NL, FI, GR, IT, NO, RO, SK, TR, RU.

#### Spezifikationen

Stromversorgung: 230V oder 110V  
 Leistung: 3,65 kW  
 Arbeitsbereich: 63 – 250 mm  
 Gesamtgewicht: 109 kg  
 Herstellergarantie: 12 Monate

#### Lieferumfang

Transportkiste beinhaltet Schweißmaschine, Heizelement, Planhobel, Reduzierungen (63, 75, 90, 110, 125, 140, 160, 180, 200, 225), Einstellkasten für Planhobel + Heizelement und Zubehör (Bedienungsanleitung, Werkzeug).

#### Description

Butt-welding machine for welding of pipes and fittings made of PE and PP from DA 63 to 250 mm, for all dimension ratios.

#### Features

- Automatic computation of all welding pressures and times.
- Automatic heating element temperature control.
- Automatic data logging up to 10.000 weldings.
- Data input RFID-Transponder, Manuell, Scanner (optional).
- System monitoring.
- Welding monitoring system.
- Traceability pursuant to ISO 12176-1
- Welding standards: DVS, WIS, SEDIGAS, UNI, NEN.
- Data output via print menu.
- Languages: DE, EN, FR, BG, CS, ZH, NL, FI, GR, IT, NO, RO, SK, TR, RU.

#### Specifications

Power supply: 230V or 110V  
 Power: 3,65 kW  
 Operating range: O.D. 63 – 250 mm  
 Total weight: 109 kg  
 Manufacturer warranty: 12 months

#### Scope of delivery

Transport case incl. welding machine, heating element, facing tool, reducers (63, 75, 90, 110, 125, 140, 160, 180, 200, 225), carrying rack for heating element + facing tool and accessories (User's manual, tools).

Technische Änderungen vorbehalten • Specifications subject to change without notice.

Teil / Item	Beschreibung • Description
9505 0030 30	HST WeldControl 2.0 - 250 Set 230V
9505 0031 30	HST WeldControl 2.0 - 250 Set 110V



### HST-300 Manual USB 2.0

Heizwendel-Muffen-Schweißmaschine für PE- und PP-Heizwendel-Formteile bis 1200 mm  
Electrofusion socket-welding machine for PE- and PP-Electrofusion fittings up to 1200 mm

#### Beschreibung

Schweißmaschine für Heizwendel-Formteile aus PE/PP bis 1200 mm mit USB-Schnittstelle.

#### Merkmale

- Manuelle Dateneingabe von Formteilcodenummer oder Schweißspannung und Schweißzeit. Alle Dateneingaben über neuartige GT-Tastatur möglich.
- Robustes, hochauflösendes und temperaturerweitertes Display mit 5 mm Zeichenhöhe.
- Schweißüberwachungssystem (Schweißspannung, Widerstand, Schweißstrom, Kontakt, Kurzschluss, Umgebungstemperatur, Eingangsfrequenz, Eingangsspannung, Gerätetemperatur und Wartungsanzeige).
- Systemüberwachung (Systemcheck, computergesteuerter Wartungsprozess).
- USB-Schnittstelle zur Protokollierung.
- Einheitenumstellung (Inch/mm, °F/°C), Wartungsfirmen-Anzeige.
- Sprachen: DE, EN, FR, BG, CS, ZH, NL, FI, GR, IT, NO, RO, SK, TR, RU. Weitere auf Anfrage.
- 12 Monate Herstellergarantie.

#### Technische Daten

Ausgangsspannung: 8 - 48V  
Ausgangsstrom: max. 110A  
Eingangsspannung: 180 – 280V (230V), optional 110V  
Eingangsfrequenz: 40 – 70Hz  
Stromaufnahme: AC 16A  
Temperaturbereich: -20 bis +60°C  
Netzkabel: 5m mit Eurostecker  
Schweißkabel: 4m mit 4,7mm Anschlusskontakten  
Gewicht: 16 kg  
Abmessungen: B 236 x H 295 x T 330 mm

#### Lieferumfang

Verpackung beinhaltet Schweißmaschine, Bedienungsanleitung DE EN FR, Adapter 4,0mm in Adaptertasche, Operator-Barcodekarte und Aluminium-Transportkiste.

#### Description

Welding machine for electro-fusion fittings of PE/PP up to 1200 mm with USB port.

#### Features

- Manual input of numeric fitting code or welding voltage and welding time; all inputs with novel GT keypad.
- Robust, high-resolution and temperature-extended screen with character size 5 mm.
- Welding monitoring system (Welding voltage, resistance, welding current, established contact, short circuit, ambient temperature, input frequency, input voltage, unit temperature, maintenance interval).
- System self monitoring (System check, computerized maintenance management).
- USB port for protocol management.
- Measurement unit selection (Inch/mm, °F/°C), Info of servicing company.
- Languages: DE, EN, FR, BG, CS, ZH, NL, FI, GR, IT, NO, RO, SK, TR, RU. Others upon request.
- 12 months manufacturer warranty.

#### Technical Specifications

Output Voltage: 8 - 48V  
Output Current: max. 110A  
Input Voltage: 180 – 280V (230V), optional 110V  
Input Frequency: 40 – 70Hz  
Rated Power: AC 16A  
Temperature Range: -20 to +60°C  
Power Supply Cord: 5m with Euro plug  
Welding Cable: 4m with 4,7mm connection terminals  
Weight: 16kg  
Dimensions: W 236 x H 295 x T 330mm

#### Scope of delivery

Packaging includes welding machine, user's manual DE EN FR, adapter 4.0mm in adapter bag, operator bar code card and Aluminium transport box.

Technische Änderungen vorbehalten • Specifications subject to change without notice.

Teil / Item	Beschreibung • Description
9506 0001 30	HST-300 Manual USB 2.0 - 230V
9506 0002 30	HST-300 Manual USB 2.0 - 110V



### HST-300 Junior+ 2.0

Heizwendel-Muffen-Schweißmaschine für PE- und PP-Heizwendel-Formteile bis 1200 mm  
Electrofusion socket-welding machine for PE- and PP-Electrofusion fittings up to 1200 mm

#### Beschreibung

Schweißmaschine für Heizwendel-Formteile aus PE/PP bis 1200 mm und Barcode-Scanner.

#### Merkmale

- Dateneingabe über Barcode-Scanner, optional Lesestift. Alle Dateneingaben über neuartige GT-Tastatur möglich.
- Robustes, hochauflösendes und temperaturerweitertes Display mit 5 mm Zeichenhöhe.
- Schweißüberwachungssystem (Schweißspannung, Widerstand, Schweißstrom, Kontakt, Kurzschluss, Umgebungstemperatur, Eingangsfrequenz, Eingangsspannung, Gerätetemperatur und Wartungsanzeige).
- Systemüberwachung (Systemcheck, computergesteuerter Wartungsprozess).
- ViewWeld-Funktion, Einheitenumstellung (Inch/mm, °F/°C), Wartungsfirmen-Anzeige.
- Sprachen: DE, EN, FR, BG, CS, ZH, NL, FI, GR, IT, NO, RO, SK, TR, RU. Weitere auf Anfrage.
- 12 Monate Herstellergarantie

#### Technische Daten

Ausgangsspannung: 8 - 48V  
Ausgangsstrom: max. 110A  
Eingangsspannung: 180 – 280V (230V), optional 110V  
Eingangsfrequenz: 40 – 70Hz  
Stromaufnahme: AC 16A  
Temperaturbereich: -20 bis +60°C  
Netzkabel: 5m mit Eurostecker  
Schweißkabel: 4m mit 4,7mm Anschlusskontakten  
Gewicht: 16 kg  
Abmessungen: B 236 x H 295 x T 330 mm

#### Lieferumfang

Verpackung beinhaltet Schweißmaschine mit Barcode-Scanner, Bedienungsanleitung DE EN FR, Adapter 4,0mm in Adaptertasche, Operator-Barcodekarte und Aluminium-Transportkiste.

#### Description

Welding machine for electro-fusion fittings of PE/PP up to 1200 mm and barcode-scanner.

#### Features

- Data input: Bar code scanner, optionally scanning pen; all inputs with novel GT keypad.
- Robust, high-resolution and temperature-extended screen with character size 5 mm.
- Welding monitoring system (Welding voltage, resistance, welding current, established contact, short circuit, ambient temperature, input frequency, input voltage, unit temperature, maintenance interval).
- System self monitoring (System check, computerized maintenance management).
- ViewWeld feature, Measurement unit selection (Inch/mm, °F/°C), Info of servicing company.
- Languages: DE, EN, FR, BG, CS, ZH, NL, FI, GR, IT, NO, RO, SK, TR, RU. Others upon request.
- 12 months manufacturer warranty.

#### Technical Specifications

Output Voltage: 8 - 48V  
Output Current: max. 110A  
Input Voltage: 180 – 280V (230V), optional 110V  
Input Frequency: 40 – 70Hz  
Rated Power: AC 16A  
Temperature Range: -20 to +60°C  
Power Supply Cord: 5m with Euro plug  
Welding Cable: 4m with 4,7mm connection terminals  
Weight: 16kg  
Dimensions: W 236 x H 295 x T 330mm

#### Scope of delivery

Packaging includes welding machine with bar-code scanner, user's manual DE EN FR, adapter 4.0mm in adapter bag, operator bar code card and Aluminium transport box.

Technische Änderungen vorbehalten • Specifications subject to change without notice.

Teil / Item	Beschreibung • Description
9506 0003 30	HST-300 Junior+ 2.0 - 230V
9506 0004 30	HST-300 Junior+ 2.0 - 110V
	Optionen • optional
9506 0011 30	HST-300 Lesestift • Scanning pen



### HST-300 Print+ 2.0

Heizwendel-Muffen-Schweißmaschine für PE- und PP-Heizwendel-Formteile bis 1200 mm  
 Electrofusion socket-welding machine for PE- and PP-Electrofusion fittings up to 1200 mm

#### Beschreibung

Schweißmaschine für Heizwendel-Formteile aus PE/PP bis 1200 mm, Barcode-Scanner und automatischer Protokollierung.

#### Merkmale

- 10.000 Protokolle.
- Manuelle Dateneingabe von Formteilcodenummer oder Schweißspannung und Schweißzeit. Alle Dateneingaben über neuartige GT-Tastatur möglich.
- Robustes, hochauflösendes und temperaturerweitertes Display mit 8 mm Zeichenhöhe.
- Schweißüberwachungssystem (Schweißspannung, Widerstand, Schweißstrom, Kontakt, Kurzschluss, Umgebungstemperatur, Eingangsfrequenz, Eingangsspannung, Gerätetemperatur und Wartungsanzeige).
- Systemüberwachung (Systemcheck, computergesteuerter Wartungsprozess inkl. Protokollierung)
- Rückverfolgbarkeit nach ISO 12176-3/4.
- Datenausgabe über Druckmenü (USB-Schnittstelle) auf Drucker oder Stick im PDF-Format oder im DataWork-Format an den PC.
- Menügeführte Protokollansicht inkl. Suchfunktion, ViewWeld-Funktion, Speicher-Backup-Funktion, AutoWeld-Funktion, Summer-Lautstärkeregelung, Einheitenumstellung (Inch/mm, °F/°C), Wartungsfirmen-Anzeige.
- Sprachen: DE, EN, FR, BG, CS, ZH, NL, FI, GR, IT, NO, RO, SK, TR, RU. Weitere auf Anfrage.
- 12 Monate Herstellergarantie

#### Technische Daten

Ausgangsspannung: 8 - 48V  
 Ausgangsstrom: max. 110A  
 Eingangsspannung: 180 – 280V (230V), optional 110V  
 Eingangsfrequenz: 40 – 70Hz  
 Stromaufnahme: AC 16A  
 Temperaturbereich: -20 bis +60°C  
 Netzkabel: 5m mit Eurostecker  
 Schweißkabel: 4m mit 4,7mm Anschlusskontakten  
 Gewicht: 16 kg  
 Abmessungen: B 236 x H 295 x T 330 mm

#### Lieferumfang

Verpackung beinhaltet Schweißmaschine mit Barcode-Scanner, Bedienungsanleitung DE EN FR, Adapter 4,0mm in Adaptertasche, Operator-Barcodekarte und Aluminium-Transportkiste.

#### Description

Welding machine for electro-fusion fittings of PE/PP up to 1200 mm, barcode-scanner and automatic data logging.

#### Features

- 10,000 reports.
- Manual input of numeric fitting code or welding voltage and welding time; all inputs with novel GT keypad.
- Robust, high-resolution and temperature-extended screen with character size 8 mm.
- Welding monitoring system (Welding voltage, resistance, welding current, established contact, short circuit, ambient temperature, input frequency, input voltage, unit temperature, maintenance interval).
- System self monitoring (System check, computerized maintenance management incl. recording).
- Traceability pursuant to ISO 12176-3/4.
- Data output via print menu (USB interface) to printer or stick in PDF-format or in DataWork format to computer.
- Intuitive report review menu incl. search, ViewWeld feature, memory backup, AutoWeld feature, buzzer volume set point, measurement unit selection (Inch/mm, °F/°C), Info of servicing company.
- Languages: DE, EN, FR, BG, CS, ZH, NL, FI, GR, IT, NO, RO, SK, TR, RU. Others upon request.
- 12 months manufacturer warranty.

#### Technical Specifications

Output Voltage: 8 - 48V  
 Output Current: max. 110A  
 Input Voltage: 180 – 280V (230V), optional 110V  
 Input Frequency: 40 – 70Hz  
 Rated Power: AC 16A  
 Temperature Range: -20 to +60°C  
 Power Supply Cord: 5m with Euro plug  
 Welding Cable: 4m with 4,7mm connection terminals  
 Weight: 16kg  
 Dimensions: W 236 x H 295 x T 330mm

#### Scope of delivery

Packaging includes welding machine with barcode scanner, user's manual DE EN FR, adapter 4.0mm in adapter bag, operator bar code card and Aluminium transport box.

Technische Änderungen vorbehalten • Specifications subject to change without notice.

Teil / Item	Beschreibung • Description
9506 0005 30	HST-300 Print+ 2.0 - 230V
9506 0006 30	HST-300 Print+ 2.0 - 110V
Optionen • optional	
9505 0011 30	HST-300 Lesestift • Scanning pen

 Handschaber  
 Scraper manual

Teil / Item	Größe/Size	Beschreibung • Description	KG	VE1	VE2
9506 0052 30	70 mm	1-fach Klinge • 1 fold blade	0,15	1	-
9506 0053 30	35 mm	4-fach Klinge • 4 fold blade	0,10	1	-
9506 0054 30	70 mm	4-fach Klinge mit Druckknopf • 4 fold blade with push button	0,27	1	-

## HST Rotations-Schälwerkzeuge

### HST Rotating scrapers

Rotations-Schälgeräte für Rohrenden und Sattelflächen zur fachgerechten und zeitsparender Vorbereitung des Schweißbereichs an Rohren zur Verwendung von Heizwendel-Schweiß-Formteilen.

Sicheres Entfernen der Oxidschicht auf der Oberfläche von Rohren bei geringem Kraftaufwand. Durch das federelagerte Messer und den automatischen Vorschub erfolgt eine kontinuierliche Anpassung an Rohr-Ovalitäten und Toleranzen, wodurch ein gleichmäßiger Spanabtrag gewährleistet ist. Das hochwertige Wendemesser aus Hartmetall garantiert eine äußerst lange Standzeit.

Nach DVS 2207 ist die Verwendung von Handschabergeräten nur in Ausnahmefällen zulässig und zu begründen.

Inklusive Stahl-Transportkoffer und Werkzeug.

Rotating scrapers for pipe ends and saddle areas for professional and time efficient preparation of the welding zone of pipes for the use of electrofusion welding fittings. Reliable removal of the oxide layer on the surface of pipes with little force. The spring-mounted blade and the automatic feed ensure continuous adaptation to pipe ovality and tolerances; whereby a constant chip removal is ensured. The high-quality turnable carbide metal knife guarantees an extremely long operating life.

According to DVS 2207, the use of hand tools is only allowed in exceptional cases and to be justified.

Inclusive steel transport box and tools.



HST Rotations-Schälwerkzeug für Sattelflächen und Rohrenden

HST Rotating scraper for saddle areas and pipe ends

Teil / Item	DA/OD [mm]	Beschreibung • Description	KG	VE1	VE2
9503 0066 30	63 - 180	Größe • Size - 2 / 180	10,0	1	-
9503 0067 30		Ersatzmesser für Größe • Replacement knife for size - 2	0,01	1	-

HST Rotations-Schälwerkzeug für Rohrenden

HST Rotating scraper for pipe ends



Teil / Item	DA/OD [mm]	Beschreibung • Description	KG	VE1	VE2
9503 0060 30	32 - 160	Größe • Size - 1 / 160	4,50	1	-
9503 0061 30	63 - 250	Größe • Size - 1.5 / 250	9,00	1	-
9503 0062 30	110 - 500	Größe • Size - 2 / 500	10,0	1	-
9503 0063 30	560 - 1000	Größe • Size - 3 / 1000	1	1	-
9503 0064 30		Ersatzmesser für Größe • Replacement knife for size - 1, 1.5, 2	0,10	1	-
9503 0065 30		Ersatzmesser für Größe • Replacement knife for size - 3	0,10	1	-



Teil / Item	D [mm]	Beschreibung	Description	KG	VE1	VE2
9503 0080 30	20-75	HST Universal Haltevorrichtung 75, D20-75mm inkl. Tragetasche, L610 x B225 x H115mm	HST All-purpose Pipe Aligner 75, D20-75mm incl. transport bag, L610 x W225 x H115mm	4,50	1	-
9503 0081 30	75-180	HST Universal Haltevorrichtung 180, D75-180mm inkl. Transport-Box, L980 x B430 x H260mm	HST All-purpose Pipe Aligner 180, D75-180mm incl. transport box, L980 x W430 x H260mm	16,40	1	-
9503 0082 30	125-500	HST Universal Haltevorrichtung 500, D125-500mm inkl. Transport-Box	HST All-purpose Pipe Aligner 500, D125-500mm incl. transport box	47,50	1	-

### HST Rundungsschalen + Rundungsschellen

Für das Runden von Rohren beim Verschweißen von Heizwendel-Schweiß-Formteilen. Auch verwendbar für andere Schweißverfahren.

#### Rounding shell + Rounding clamp

For rounding of pipes during the welding of electrofusion welding fittings. Also useable for other welding technics.



HST Rundungsschelle RSH, Stahl, Oberfläche verzinkt, ohne Hydraulikzylinder

HST Rounding clamp RSH, steel, surface galvanized, without hydraulic cylinder

HST Rundungsschalen, verzinkt, mit 4 Schrauben + Langmuttern  
HST Rounding shell, galvanized, with 4 screws + long nuts

Teil / Item	DA/OD [mm]	Beschreibung Description	KG	VE1	VE2
9506 0101 30	250	15,70	1	-	
9506 0102 30	280	16,80	1	-	
9506 0103 30	315	17,90	1	-	
9506 0104 30	355	19,9	1	-	
9506 0105 30	400	25,4	1	-	
9506 0106 30	450	26,9	1	-	
9506 0107 30	500	28,5	1	-	
9506 0108 30	560	32,9	1	-	
9506 0109 30	630	36,9	1	-	
9506 0110 30	710	38,6	1	-	
9506 0111 30	800	43,4	1	-	

Teil / Item	DA/OD [mm]	Beschreibung Description	KG	VE1	VE2
9506 0090 30	63	4,0	1	-	
9506 0091 30	75	4,5	1	-	
9506 0092 30	90	5,0	1	-	
9506 0093 30	110	7,0	1	-	
9506 0094 30	125	8,0	1	-	
9506 0095 30	140	9,0	1	-	
9506 0096 30	160	11,0	1	-	
9506 0097 30	180	12,0	1	-	
9506 0098 30	200	13,0	1	-	
9506 0099 30	225	15,0	1	-	
9506 0100 30	250	18,0	1	-	

HST Hydraulikzylinder für Rundungsschelle RSH  
HST Hydraulic cylinder for rounding clamp RSH

9506 0112 30	250 - 800	15,4	1	-	
--------------	-----------	------	---	---	--



8986b Bohrer Einschweißsattel  
Driller weld-in-saddle

Teil / Item	d [mm]	KG	VE1	VE2
9507 07B0 09	25	0,15	1	-
9507 08B0 09	32	0,22	1	-
9507 09B0 09	40	0,23	1	-
9507 10B0 09	50	0,33	1	-
9507 11B0 09	63	0,45	1	-



8984e Schweißwerkzeug Einschweißsattel Teflon-beschichtet  
Welding tool weld-in-saddle Teflon-coated

Teil / Item	d x d2 [mm]	KG	VE1	VE2
9507 0907 09	40-63 x 25	0,24	1	-
9507 0908 09	40-63 x 32	0,25	1	-
9507 1207 09	75-125 x 25	0,28	1	-
9507 1208 09	75-125 x 32	0,41	1	-
9507 1209 09	75-125 x 40	0,36	1	-
9507 1410 09	75-125 x 50	0,65	1	-
9507 1511 09	75-125 x 63	1,05	1	-
9507 1707 09	160-250 x 25	0,17	1	-
9507 1708 09	160-250 x 32	0,23	1	-
9507 1709 09	160-250 x 40	0,36	1	-
9507 1710 09	160-250 x 50	0,65	1	-
9507 1711 09	160-250 x 63	1,04	1	-
9507 2307 09	315-630 x 25	0,15	1	-
9507 2308 09	315-630 x 32	0,20	1	-
9507 2309 09	315-630 x 40	0,35	1	-
9507 2310 09	315-630 x 50	0,65	1	-
9507 2311 09	315-630 x 63	1,10	1	-

**HORNET™**

Polypropylen Abgangs-Herstellungs-Werkzeug für Abgänge von 20 bis 63mm auf 40 bis 630mm Leitungsdurchmesser.

**HORNET™**

Polypropylene outlet fusion tool for branch sizes 20 to 63mm on to 40 to 630mm main sizes.

**Beschreibung**

Der HORNET - ein neues Universal-Werkzeug für die Polypropylen-Einschweißsättel - ist eine Neuheit. Es bringt eine innovative Alternative zu manuellen Methoden von Abgängen, die produktiver, effizienter und zuverlässiger als je zuvor ist. Das patentrechtlich geschützte Design der HORNET ermöglicht es, sich auf der Mitte des Rohres selbst auszurichten, während ein geführter Schlitten das Bohren des Auslasslochs und die Einführung des Sattels erleichtert - alles perfekt ausgerichtet hält, ohne die Maschine neu zu positionieren.

Die einzigartigen Schnellwechselbohrer- und Befestigungsadapter von HORNET im Schlitten sind leicht wechselbar, so dass das Auslassloch und die Ausrichtung des Sattels während des gesamten Prozesses überein stimmt und so eine genauere Verbindung entsteht.

Mit einer kleinen Stellfläche und einem Gewicht von nur 15 Pfund ist der HORNET in der Lage, in jeder Orientierung zu arbeiten - ideal für Über-Kopf und vertikale Verbindungen in engen Räumen. Der HORNET arbeitet mit allen vorhandenen Heizelementen und Einschweißsätteln für Polypropylen-Rohr. Ein integrierter Ratschenriemen ermöglicht es, den HORNET an einer breiten Palette von Rohr-Dimensionen von 40 bis 630mm zu befestigen, während die Einschweiß-Sättel für 20mm bis 63mm Abgänge installiert werden.

**Merkmale**

- Eloxierte Aluminium-Verschleißflächen für Korrosionsbeständigkeit
- Schnellwechselbohrer und passender Adapter für effiziente Verbindungen
- Zahnstangenantrieb für leichtgängigen Betrieb
- Selbstzentrierende Grundkonstruktion sorgt dafür, dass die Verbindungsvorgänge auf der Rohrmitte ausgerichtet sind
- Integrierter Ratschenriemen ermöglicht den Betrieb über ein breites Spektrum an Rohrgrößen
- Leicht und kompakt
- Arretierung des Schlittens in Position

**Spezifikationen**

Abgangsgröße: 20 - 63mm  
 Hauptrohrgröße: 40 - 630mm  
 Maschinengewicht: 6,9 kg (15.3 lbs.)  
 Maximale Hublänge: 206mm (8 Zoll)

**Lieferumfang**

Verpackung beinhaltet Hornet Maschine, Bohrer und Montageadapter, Ratschenriemen, Zubehörfutter und Tragekoffer.  
 Bohrer nicht inbegriffen. Schneider, Heizelement- und Schweiß-Werkzeuge sind separat erhältlich.

**Description**

The HORNET — a new all-in-one tool for polypropylene outlet fusion — is an industry first. It brings an innovative alternative to manual outlet fusion methods that is more productive, efficient and reliable than ever before. The Hornet's patent-pending design allows it to self-align on the center of the pipe while a guided carriage facilitates the drilling of the outlet hole and fusion of the fitting — keeping everything perfectly aligned without repositioning the machine.

The HORNET's unique quick-change drill and fitting adapters easily swap in and out of the carriage which keeps the outlet hole and fitting aligned throughout the entire process — creating a more accurate fusion.

With a small footprint and weighing just 15 pounds, the HORNET is capable of performing in any orientation — making it ideal for overhead and vertical fusions in tight spaces. The HORNET works with all existing socket heaters and fusion outlet welding heads for polypropylene pipe. An integrated ratchet strap allows it to attach to a wide range of main sizes from 40mm to 630mm while installing outlets for 20mm to 63mm branches.

**Features**

- Anodized aluminium wear surfaces for corrosion resistance
- Quick-change drill and fitting adapter for efficient fusions
- Rack and pinion drive for smooth operation
- Self-centering base design ensures fusion operations align on center of pipe
- Integrated ratchet strap allows operation across wide range of pipe sizes
- Light weight and compact
- Carriage locks in position

**Specifications**

Branch Size: 20 – 63mm  
 Main Size: 40 – 630mm  
 Machine Weight: 6,9 kg (15.3 lbs.)  
 Maximum Stroke Length: 206mm (8 inch)

**Scope of delivery**

Packaging includes HORNET fusion machine, drill and fitting adapters, ratchet strap, accessory case and carrying case.  
 Drill not included. Cutters, heater and heater adapters sold separately.

Technische Änderungen vorbehalten • Specifications subject to change without notice.

Teil / Item **9507 0001 30**

## 6.05.08 Schälwerkzeuge Stabitec • Peeling tools Stabitec



8977 Schälgerät STABITEC kombi  
Peeling tool STABITEC combi

Teil / Item	d [mm]	KG	VE1	VE2
9508 0506 09	16 + 20	0,32	1	-
9508 0607 09	20 + 25	0,30	1	-
9508 0809 09	32 + 40	0,44	1	-
9508 1011 09	50 + 63	1,12	1	-



8977 Schälgerät STABITEC  
Peeling tool STABITEC

Teil / Item	d [mm]	KG	VE1	VE2
9508 1200 09	75	1,27	1	-
9508 1300 09	90	1,33	1	-
9508 1400 09	110	1,72	1	-
9508 1500 09	125	2,50	1	-



8986a Anfaswerkzeug Einschweißsattel  
STABITEC  
Chamfering tool weld-in-saddle  
STABITEC

Teil / Item	d [mm]	KG	VE1	VE2
9508 07A0 09	25	0,31	1	-



Ersatzklinge für Schälgeräte für STABITEC  
Replacement blade for peeling tools STABITEC  
Teil / Item 9508 0001 09

## 6.05.09 Reparatursets • Repair sets



Teil / Item	Beschreibung	Description	KG	VE1	VE2
9509 0001 30	Reparatur-Set Lochstopfen D7 für Bohrlöcher bis 6mm	Repair set hole plug D7 for drill holes up to 6mm	0,15	1	-
9509 0002 30	Reparatur-Set Lochstopfen D11 für Bohrlöcher bis 10mm	Repair set hole plug D11 for drill holes up to 10mm	0,15	1	-
9509 0003 01	Lochstopfen grün D7 für Bohrlöcher bis 6mm	Hole plug green D7 for drill holes up to 6mm	0,01	1	-
9503 0004 01	Lochstopfen grün D11 für Bohrlöcher bis 10mm	Hole plug green D11 for drill holes up to 10mm	0,01	1	-



## TESTO 925 Set

### Temperatur-Messgerät (1-Kanal) mit Fühler.

Temperature measuring instrument (1-channel) with sensor.

#### Beschreibung

Das TESTO 925 ist ein 1-Kanal-Temperatur-Messgerät, welches insbesondere für den Einsatz im HVAC-Bereich geeignet ist. Das Gerät ist optimal für den Anschluss von schnellen und zuverlässigen Thermoelement-Fühlern geeignet. Das Gerät zeigt fortlaufend zuverlässig die Minimal- und Maximalwerte an. Es können Grenzwerte hinterlegt werden und es ertönt ein akustisches Warnsignal wenn die Werte unter- oder überschritten werden.

Das Gerät eignet sich somit optimal zur Überprüfung der Temperaturen an Heizelementen.

Optional: Funkfühler und Protokolldrucker.

#### Technische Daten

Sensortyp: K (NiCr-Ni)  
 Messbereich Sensor: -50 - +1000 °C  
 Auflösung: 0,1 °C (-50 - +199,9 °C)  
 Betriebstemperatur: -20 - +50 °C  
 Lagertemperatur: -40 - +70 °C  
 Batterietyp: 9V-Block, 6F22  
 Standzeit: bis zu 200 h  
 Abmessung: 182 x 64 x 40 mm  
 Gewicht: 171 g  
 Herstellergarantie: 2 Jahre

#### Lieferumfang

Verpackung beinhaltet Messgerät und Sensor.

#### Description

The TESTO 925 is a 1-channel temperature measuring instrument, which is particularly suitable for use in the HVAC range. The device is perfect for the connection of fast and reliable thermoelement sensors. The device constantly displays the minimum and maximum values reliably. Limits can be stored and an acoustic warning signal sounds when the values are below or exceeded.

The device is therefore ideally suited for checking the temperatures at heating elements.

Optional: wireless sensor and protocol printer.

#### Features

Type of sensor: K (NiCr-Ni)  
 Measuring range sensor: -50 - +1000 °C  
 Resolution: 0.1 °C (-50 to +199.9 °C)  
 Operating temperature: -20 - +50 °C  
 Storage temperature: -40 - +70 °C  
 Battery type: 9V block, 6F22  
 Working time: up to 200 h  
 Dimension: 182 x 64 x 40 mm  
 Weight: 171 g  
 Manufacturing guarantee: 2 years

#### Scope of delivery

Packaging includes measuring instrument and sensor.

Technische Änderungen vorbehalten • Specifications subject to change without notice.

Teil / Item **9510 0001 30**



G 8670

Teil / Item	G [Inch]	Beschreibung	Description	KG	VE1	VE2
9901 0001 39	3/4	MS-Druckminderer PN16 AG Druck einstellbar von 1,5 bis 5,5 bar, für flachdichtende Anschlussverschraubungen, Anschlußmöglichkeit für Manometer.	Brass-Pressure reducer PN16 male-thread pressure adjustable from 1,5 to 5,5 bar, for flat sealing connection unions, connection for pressure gauge.	0,35	1	-



G 8670A

Teil / Item	G [Inch]	Beschreibung	Description	KG	VE1	VE2
9901 0002 30	1/4	Manometer 0-10bar (0-145PSI) AG für Druckminderer	Pressure Gauge 0-10bar (0-145PSI) male-thread for pressure reducer	0,19	1	-



G 8670A

Teil / Item	G [Inch]	Beschreibung	Description	KG	VE1	VE2
9901 0003 39	3/4	Ms Rückschlagventil PN16 IG	Brass Non-return valve PN16 female-thread	0,17	1	-

## **A** Anhang • Appendix

---

- A1 Zeichenerklärung • Legend
- A2 Rechtliche Hinweise • Legal notice
- A3 Verkaufsbedingungen • Conditions of sale

# A1 Zeichenerklärung • Legend

## Werkstoffe • Materials

	Deutsch	Englisch
EcoB	EcoBrass (Messing Bleifrei)	EcoBrass (Leadfree Brass)
EPDM	Ethylen-Propylen-Kautschuk	nitrile rubber
FCKW	Fluorchlorkohlenwasserstoffe	Chlorofluorocarbon
FKM (FPM)	Fluor-Kautschuk	fluor rubber
GGG	Grauguß globular	cast iron globular
GJMW (GTW)	Temperguss	malleable iron
Ms	Messing	brass
NBR	Nitril-Kautschuk	nitrile rubber
PB	Polybuthylen	Polybuthylene
PE	Polyethylen	Polyethylene
PE100	PE-Festigkeitsklasse nach ISO 9080	PE strength class according ISO 9080
PE-HD	PE-Hohe Dichte	PE-High density
PP	Polypropylen	Polypropylene
PP-R	Polypropylen – Random copolymer	Polypropylene - Random copolymer
PP-RCT	PP-R mit modifizierter Kristallstruktur und erhöhter Temperaturbeständigkeit.	PP-R with modified crystalline structure and increased temperature resistance.
PTFE	Polytetrafluorethylen	Polytetrafluorethylene
PVC	Polyvinylchlorid	Polyvinylchloride
PVC-U	Weichmacherfreies PVC (hart)	unplasticized PVC
RG	Rotguss	bronze
St	Stahl	steel
V2A	Nicht rostender Stahl (Edelstahl)	stainless steel

## Normen, Richtlinien • Standards, guidelines

	Deutsch	Englisch
ANSI	Amerikanische Organisation zur Koordinierung der Entwicklung freiwilliger Normen	American National Standard Institute
DIN	Deutsches Institut für Normung	German institute for standards
DIN Certco	Zertifizierungsorganisation des DIN	Certification organization of DIN
DVGW	Deutscher Verein des Gas- und Wasserfaches	German association for gas and water profession
DVS	Deutscher Verband für Schweißen	German welding association
EN	Europäische Norm	European standard
GW	Arbeitsblatt des DVGW	Working sheet of DVGW
ISO	Internationale Organisation für Normung	International Standardisation Organisation
KTW	Kunststoffe in Kontakt mit Trinkwasser	Plastics in drinking water
MRS	Erforderliche Mindestfestigkeit	minimum required strength
NSF	Nationale Wissenschafts Stiftung	National Science Foundation
RAL	Deutsches Institut für Gütesicherung und Kennzeichnung	German institute for quality control and labeling
TÜV	Technischer Überwachungsverein	Association for Technical Inspection
WRAS	Britisches Konformitätszeichen im Wasserbereich	Water Regulations Advisory Scheme
ZP	DIN Certco Richtlinie	DIN Certco guideline

## Maße, Dimensionen • Measures, dimensions

	Deutsch	Englisch
AG / m	Außengewinde	outside thread / male
B, b	Breite	width
C	Flanschstärke	flange thickness
D, Da	Außendurchmesser	outside diameter
d, Di	Innendurchmesser	inside diameter
DK	Lochkreisdurchmesser	hole circle diameter
DL	Lochdurchmesser	hole diameter
DN	Nennendurchmesser	Diameter Nominal
e	Wandstärke	wall thickness
G	Gewinde – zylindrisch Nicht im Gewinde dichtend	thread – cylindrical not tightening
H, h	Höhe	height
i-a / f-m	Innen-außen	inside-outside / female-male
IG / fem	Innengewinde	inside thread / female
keg / con	Kegelig (konisch)	conical
kg	Kilogramm	kilogram
L, l	Länge	length
lbs	Amerikanische Gewichtseinheit (Pfund)	American weight unit (pound)
m	Meter	meter
mm	Millimeter	millimeter
mPa	Mega Pascal (Druckeinheit)	mega Pascal (pressure unit)
nL	Anzahl Löcher	number of holes
NPT	Rohraußen-, -innengewinde - kegelig	pipe outside/inside thread, conical
P	Druck	pressure
PN	Nenndruck	Pressure Nominal
r	Radius	radius
R	Rohraußengewinde – kegelig, im Gewinde dichtend	pipe thread male – conical, tightening
Rc	Rohrinnengewinde – kegelig, im Gewinde dichtend	pipe thread female – conical, tightening
Rp	Rohrinnengewinde – zylindrisch, im Gewinde dichtend	pipe thread female – cylindrical, tightening
S	Rohrserie (S-Klasse)	pipe series (S-class)
SDR	Rohrkennzahl	Standard Dimension Ratio
SF	Sicherheitsfaktor	safety factor
SW	Schlüsselweite	wrench size
T, t	Tiefe	depth
W/mK	Einheit der Wärmeleitfähigkeit	Unit of thermal conductivity
Z, z	z-Maß	z-dimension
zyl, cyl	zylindrisch	cylindrical
°	Grad	degrees
°C	Grad Celsius (Temperatur)	degrees Celsius (temperature)
[ ]	Einheit	unit

## Abkürzungen • Abbreviations

	Deutsch	Englisch
BB	Bundbuchse	flange adaptor socket
KL	Klappe	(shut-)valve
red	reduziert	reduced
™	Warenzeichen	Trademark
UP	Unterputz	concealed
UV	Ultraviolett	ultraviolet
Ü-	Übergangs-	transition
VB	Vorschweißbund	flange adaptor spigot
VE	Verpackungseinheit	packaging unit
©	Urheberrecht	Copyright
®	Eingetragenes Warenzeichen	registered Trademark

**Rechtliche Hinweise**

Mit Erscheinen dieses Drucks verlieren frühere Ausgaben ihre Gültigkeit. Die maßgebliche Version dieser Publikation finden Sie auf unserer Webseite [www.baenninger.de](http://www.baenninger.de).

Alle Angaben in diesem Katalog entsprechen dem heutigen Stand unserer Kenntnisse und sollen über unsere Produkte und mögliche Anwendungen informieren (Irrtümer, Änderungen und Druckfehler vorbehalten). Sie haben somit nicht die Bedeutung, bestimmte Eigenschaften der Produkte oder deren Eignung für einen konkreten Einsatzzweck rechtlich verbindlich zuzusichern.

Für Anwendungen, Verwendungen, Verarbeitungen oder den sonstigen Gebrauch dieser Informationen oder unserer Produkte, sowie die sich daraus ergebenden Folgen, übernehmen wir keine Haftung.

Der Käufer ist verpflichtet, die Qualität sowie die Eigenschaften der Produkte zu kontrollieren; er übernimmt die volle Verantwortung für Auswahl, Anwendung, Verwendung und Verarbeitung der Produkte und den Gebrauch der Informationen sowie die Folgen daraus. Etwa bestehende Schutzrechte Dritter sind zu berücksichtigen.

Eigentums- und Urheberrechte an sämtlichen Zeichnungen und Tabellen bleiben ausdrücklich vorbehalten. Wiedergabe jedweder Art – auch auszugsweise – nur nach vorheriger schriftlicher Genehmigung und mit Quellenangabe.

© Bänninger Kunststoff-Produkte GmbH, Reiskirchen.

**Legal notice**

Upon publication of this document all previous editions shall become void. The authoritative version of this publication can be found on our website at [www.baenninger.de](http://www.baenninger.de).

All information furnished herein reflects our scope of knowledge at the point of publication and is designed to provide details of our products and potential fields of application (errors, changes and omissions excepted, including typographical mistakes). The furnishing of such information shall not be deemed as constituting the provision of legally binding guarantees as to specific product-related properties of their suitability for specific areas of application.

We shall assume no liability for the application, utilisation, processing or other use of this information or of our products. Furthermore, we shall assume no liability for any consequences related thereto.

The purchaser is obliged to examine the quality and properties of these products; he shall be responsible in full for selecting, applying, utilising and processing said products as well as applying any information relating thereto, which shall also include all consequences associated with such actions. Third-party property rights shall be observed accordingly.

Ownership and copyrights of all drawings and tables are expressly reserved. Reproduction of any kind - also preferably - only with prior written permission and with source indication.

© by Bänninger Kunststoff-Produkte GmbH, Reiskirchen.

## § 1 Geltungsbereich

(1) Die Leistungen und Angebote der Bänninger Kunststoff-Produkte GmbH (nachfolgend: Lieferer genannt) erfolgen ausschließlich aufgrund dieser Verkaufs- und Lieferbedingungen. Diese gelten auch für alle zukünftigen Geschäfte mit dem Vertragspartner (nachfolgend: Besteller genannt), selbst wenn sie nicht nochmals ausdrücklich vereinbart werden. Entgegenstehende oder von diesen Verkaufs- und Lieferbedingungen abweichende Allgemeine Geschäftsbedingungen des Bestellers erkennt der Lieferer nicht an, es sei denn, der Lieferer hätte ausdrücklich schriftlich ihrer Geltung zugestimmt.

(2) Sämtliche Vereinbarungen, die zwischen dem Lieferer und dem Besteller zwecks Ausführung des Vertrages getroffen werden, sind in diesem Vertrag schriftlich niederzulegen. Zusätzliche mündliche Vereinbarungen wurden zwischen Lieferer und Besteller nicht getroffen.

(3) Diese Verkaufs- und Lieferbedingungen gelten spätestens mit der Entgegennahme der Ware oder Leistung durch den Besteller als angenommen.

(4) Diese Verkaufs- und Lieferbedingungen gelten nur gegenüber Unternehmen im Sinne von § 310 BGB.

## § 2 Angebot, Vertragsabschluss und Garantie

(1) Die Angebote des Lieferers sind stets freibleibend. Annahmeerklärungen und sämtliche Bestellungen bedürfen zu ihrer Rechtswirksamkeit der schriftlichen Bestätigung des Lieferers. Sofern die Übersendung einer Auftragsbestätigung durch den Lieferer unterbleibt, kommt der Vertrag gleichwohl zustande, wenn der Lieferer aufgrund der Bestellung ausliefert und der Besteller die Ware abnimmt.

(2) Zeichnungen, Abbildungen, Maße, Gewichte oder sonstige Leistungsdaten in Tabellen, Werbeprospekten, Katalogen oder ähnlichem des Lieferers, sind nur verbindlich, wenn dies ausdrücklich und schriftlich vereinbart wird.

(3) Eine Garantie gilt nur dann als vom Lieferer übernommen, wenn dieser schriftlich die jeweilige Eigenschaft als „garantiert“ bezeichnet hat.

## § 3 Lieferfristen und Leistungszeit

(1) Verbindliche Lieferzeiten müssen ausdrücklich und schriftlich als solche vereinbart werden. Bei sämtlichen sonstigen Lieferterminen handelt es sich lediglich um unverbindliche oder ungefähre Liefertermine und Lieferfristen, bei denen sich der Lieferer bemüht, diese einzuhalten.

(2) Lieferfristen beginnen mit dem Tag der Absendung der Auftragsbestätigung durch den Lieferer, jedoch nicht, bevor alle Einzelheiten der Ausführung der Lieferung geklärt sind und sämtliche vom Besteller zu erfüllenden Voraussetzungen vorliegen. Sofern der Besteller nach Auftragserteilung Änderungen verlangt, beginnt eine neue Lieferfrist erst mit der Bestätigung der Änderung durch den Lieferer.

(3) Lieferungen vor Ablauf der Lieferzeit sind zulässig. Bei sofortiger Lieferung der Ware kann auf die Absendung einer Auftragsbestätigung verzichtet werden. Die Bestätigung kann in diesem Fall durch einen Lieferschein ersetzt werden.

(4) Als Liefertag gilt der Tag der Meldung der Versandbereitschaft, andernfalls der Tag der Absendung der Ware. Auf Abruf bestellte Lieferungen sind innerhalb von sechs Monaten nach Auftragsbestätigung abzunehmen.

(5) Der Lieferer ist zu Teillieferungen berechtigt. Jede Teillieferung gilt als selbständiges Geschäft.

(6) Sofern der Lieferer in Lieferverzug gerät, muss der Besteller dem Lieferer zunächst eine angemessene Nachfrist zur Leistung setzen. Sofern diese Frist fruchtlos verstreicht, kann der Besteller unter den jeweiligen Voraussetzungen der §§ 280, 281, 284, 286, 323 BGB die dort geregelten Rechte geltend machen.

(7) Erhält der Lieferer aus von ihm nicht zu vertretenden Gründen Lieferungen oder Leistungen seines Vorlieferanten nicht, nicht richtig oder nicht rechtzeitig oder treten Ereignisse höherer Gewalt ein, so wird der Lieferer den Besteller darüber rechtzeitig schriftlich informieren. In diesem Fall verlängert sich die Frist um die Dauer der Behinderung. Der höheren Gewalt stehen gleich: Arbeitskämpfe, behördliche Eingriffe, Energie- und Rohstoffknappheit, unverschuldete Transportengpässe, unverschuldete Betriebsbehinderungen wie beispielsweise durch Feuer, Wasser und Maschinenschäden und alle sonstigen Behinderungen, die bei objektiver Betrachtungsweise nicht vom Lieferer schuldhaft herbeigeführt worden sind. Ist ein Liefertermin oder eine Lieferfrist verbindlich vereinbart und wird aufgrund von verschiedenen Ereignissen der vereinbarte Liefertermin oder die vereinbarte Lieferzeit um mehr als zwei Monate überschritten, so ist der Besteller berechtigt, wegen des noch nicht erfüllten Teil vom Vertrag zurückzutreten.

## § 4 Versand und Gefährübergang

(1) Soweit nichts Abweichendes schriftlich vereinbart ist, erfolgt der Versand unversichert auf Gefahr und zu Lasten des Bestellers. Die Wahl des Transportweges und des Transportmittels bleibt dem Lieferer vorbehalten. Die Gefahr des zufälligen Untergangs oder der zufälligen Verschlechterung der Ware geht mit Übergabe der zu liefernden Ware an den Besteller, den Spediteur, den Frachtführer oder die sonst zur Ausführung der Versendung bestimmten Unternehmungen, spätestens mit Verlassen der Ware des Werkes/des Lagers des Lieferers auf den Besteller über.

(2) Sofern sich die Sendung der Ware dadurch verzögert, dass der Lieferer in Folge gänzlichen oder teilweisen Zahlungsverzuges des Bestellers von seinem Zurückbehaltungsrecht Gebrauch macht, oder aus einem sonstigen vom Besteller zu vertretenden Grund, geht die Gefahr spätestens ab Datum der Mitteilung der Versandbereitschaft auf den Besteller über.

(3) Versandfertig gemeldete Ware muss unverzüglich abgerufen werden. Andernfalls ist der Lieferer berechtigt, sie nach seiner Wahl zu versenden oder auf Kosten und Gefahr des Bestellers zu lagern.

(4) Verleaganleitungen der gelieferten Ware können auf der Homepage des Lieferers ([www.baenninger.de](http://www.baenninger.de)) abgerufen werden. Sofern der Besteller die Aushändigung einer Verleaganleitung wünscht, hat er dies dem Lieferer mitzuteilen. Der Lieferer trägt in diesem Fall dafür Sorge, dass der Besteller eine technische Verleaganleitung erhält.

## § 5 Preise und Zahlungsbedingungen

(1) Die Rechnungen des Lieferers sind zahlbar innerhalb von 30 Tagen ab Rechnungsdatum ohne Abzug. Bei Zahlungen innerhalb von 10 Tagen werden, soweit der Besteller nicht mit der Begleichung von Warenforderungen in Verzug ist, 3 % Skonto gewährt. Maßgeblich ist der Tag der Gutschrift auf dem Konto des Lieferers. Mit Eintritt des Verzuges des Bestellers werden Fälligkeitszinsen in Höhe von 8 % über dem jeweiligen Basiszinssatz berechnet.

(2) Vom Besteller angebotene Wechsel werden vom Lieferer nur erfüllungshalber sowie nach ausdrücklicher Vereinbarung und unter Voraussetzung ihrer Diskontierbarkeit akzeptiert. Diskontospesen werden vom Tage der Fälligkeit des Rechnungsbetrages an seitens des Lieferers berechnet. Bei Wechseln und Schecks gilt der Tag ihrer Einlösung als Zahltag.

(3) Werden Zahlungsbedingungen durch den Besteller nicht eingehalten oder Umstände bekannt, die nach Ausübung des pflichtgemäßen kaufmännischen Ermessens des Lieferers begründete Zweifel an der Kreditwürdigkeit des Bestellers entstehen lassen, und zwar auch solche Tatsachen, die schon bei Vertragsabschluss vorlagen, dem Lieferer jedoch nicht bekannt waren oder bekannt sein müssten, so ist der Lieferer unbeschadet weitergehender gesetzlicher Rechte berechtigt, die Weiterarbeit an laufenden Verträgen oder die Belieferung einzustellen und für noch ausstehende Lieferungen, Vorauszahlungen oder Stellungen von entsprechenden Sicherheiten zu verlangen, und nach erfolglosem Verstreichen einer angemessenen Nachfrist für die Leistung von solchen Sicherheiten – unbeschadet weiterer gesetzlicher Rechte – vom Vertrag zurückzutreten. Der Besteller ist verpflichtet, dem Lieferer sämtliche durch die Nichtausführung des Vertrages entstehende Schäden zu ersetzen.

(4) Die Möglichkeit der Aufrechnung steht dem Besteller nur dann zu, wenn seine Gegenansprüche rechtskräftig festgestellt, unbestritten oder von dem Lieferer anerkannt sind. Außerdem ist der Besteller zur Ausübung eines Zurückbehaltungsrechts nur dann befugt, wenn sein Gegenanspruch auf dem gleichen Vertragsverhältnis beruht.

(5) Sofern sich aus der Auftragsbestätigung nichts anderes ergibt, gelten die Preise des Lieferers, die sich grundsätzlich in Euro verstehen, EXW (ab Werk/Lager) zzgl. MwSt. in der jeweiligen gesetzlichen Höhe. Die Preise schließen Verpackungen, Fracht, Porto und Versicherung nicht mit ein. Diese werden gesondert in Rechnung gestellt.

(6) Bei Eintritt einer wesentlichen Änderung der Kostenfaktoren, wie im Falle der Erhöhung von Materialbeschaffungskosten, Lohn und Lohnnebenkosten sowie Energiekosten ist der Lieferer berechtigt, den Preis einseitig angemessen zu erhöhen, wenn zwischen dem Vertragsabschluss mit dem Besteller und Lieferung der Ware vier Monate liegen.

(7) Abnahmeprüfzeugnisse nach DIN EN 10204-3.1 B werden mit € 25,- Bearbeitungsgebühr berechnet.

## § 6 Eigentumsvorbehalt

(1) Der Lieferer behält sich das Eigentum an der gelieferten Ware (nachfolgend „Kaufsache“) vor, bis alle Forderungen des Lieferers aus der Geschäftsverbindung mit dem Besteller beglichen sind.

(2) Der Besteller hat die Kaufsache auf eigene Kosten ausreichend, insbesondere gegen Feuer und Diebstahl zum Neuwert zu versichern.

(3) Der Besteller ist berechtigt, die Kaufsache im gewöhnlichem Geschäftsverkehr weiter zu verkaufen. Andere Verfügungen, insbesondere Verpfändungen oder Einräumung von Sicherungseigentum, sind ihm nicht gestattet.

(4) Wird die Kaufsache bei Weiterveräußerung vom Dritterwerber nicht sofort vollständig bezahlt, ist der Besteller verpflichtet, nur unter Eigentumsvorbehalt an den Dritterwerber weiter zu veräußern.

(5) Die Berechtigung zur Weiterveräußerung der Kaufsache entfällt, wenn der Besteller seine Zahlung einstellt oder gegenüber dem Lieferer in Zahlungsverzug gerät.

(6) Der Besteller tritt bereits jetzt an den Lieferer alle Forderungen einschließlich Sicherheiten und Nebenrechte in Höhe des mit dem Lieferer vereinbarten Faktura-Endbetrages einschließlich Mehrwertsteuer ab, die dem Besteller aus der Weiterveräußerung der Kaufsache gegen seinen Abnehmer oder Dritten erwachsen und zwar unabhängig davon, ob die Kaufsache ohne oder nach Verarbeitung weiterverkauft worden ist.

(7) Bei Pfändungen oder sonstigen Eingriffen Dritter hat der Besteller den Lieferer unverzüglich schriftlich unter Übergabe etwaiger Unterlagen zu benachrichtigen, damit der Lieferer Schutzklagen erheben kann.

(8) Eine etwaige Verarbeitung oder Umbildung der Kaufsache wird stets für den Lieferer vorgenommen. Wird die Kaufsache mit anderen, nicht dem Lieferer gehörenden Gegenständen verarbeitet, so erwirbt der Lieferer das Miteigentum an der neuen Sache im Verhältnis des Rechnungswertes der Kaufsache zu den anderen verarbeiteten Gegenständen zum Zeitpunkt der Verarbeitung. Für die durch Verarbeitung entstehenden Sachen gilt im Übrigen das Gleiche wie für die unter Vorbehalt gelieferte Kaufsache. Wird die Kaufsache mit anderen, dem Lieferer nicht gehörenden Gegenständen untrennbar vermischt, so erwirbt der Lieferer das Miteigentum an der neuen Sache im Verhältnis des Rechnungswertes der Kaufsache zu den anderen vermischten Gegenständen zum Zeitpunkt der Vermischung. Erfolgt die Vermischung in der Weise, dass die Sache des Bestellers als Hauptsache anzusehen ist, so gilt als vereinbart, dass der Besteller dem Lieferer anteilmäßig Miteigentum überträgt. Der Besteller verwahrt das so entstandene Alleineigentum oder Miteigentum für den Lieferer.

(9) Der Besteller tritt an den Lieferer auch die Forderungen zur Sicherung der Forderungen des Lieferers gegen den Besteller ab, die durch die Verbindung der Kaufsache mit einem Grundstück gegen einen Dritten erwachsen.

(10) Der Lieferer verpflichtet sich, die ihm zustehenden Sicherheiten auf Verlangen des Bestellers insoweit freizugeben, als der realisierbare Wert der Sicherheit des Lieferers die zu sichernde Forderung um mehr als 20 % übersteigt. Die Auswahl der freizugebenden Sicherheiten obliegt dem Lieferer.

## § 7 Gewährleistung / Haftung

(1) Der Besteller ist verpflichtet, die gelieferte Ware auf offensichtliche Mängel, die ohne Weiteres auffallen, zu untersuchen. Zu den offensichtlichen Mängeln zählen beispielsweise erhebliche, leicht sichtbare Beschädigungen der Ware. Ferner sind Fälle hierunter zu fassen, in denen eine andere Sache oder eine zu geringe Menge geliefert werden. Solche offensichtlichen Mängel sind bei dem Lieferer innerhalb von zwei Wochen nach Lieferung schriftlich zu rügen. Bei Anlieferung erkennbare Mängel, müssen zudem bei dem Transportunternehmen gerügt werden und die Aufnahme der Mängel von diesem veranlasst werden.

(2) Mängel, die erst später offensichtlich werden, müssen beim Lieferer innerhalb von zwei Wochen nach dem Erkennen durch den Anwender gerügt werden. Bei Verletzung der Untersuchungs- und Rügepflicht durch den Besteller gilt die Ware in Ansehung des betreffenden Mangels als genehmigt.

(3) Mängel der gelieferten Sache werden vom Lieferer innerhalb von einem Jahr ab Lieferung nach entsprechender Mitteilung durch den Besteller behoben. Dies geschieht nach Wahl des Bestellers durch kostenfreie Nachbesserung oder Ersatzlieferung. Im Falle der Ersatzlieferung ist der Besteller verpflichtet, die mangelhafte Sache zurückzugewähren.

(4) Kann der Mangel nicht innerhalb angemessener Frist behoben werden oder ist die Nachbesserung oder Ersatzlieferung aus sonstigen Gründen als fehlgeschlagen anzusehen, kann der Besteller nach seiner Wahl Herabsetzung der Vergütung (Minderung) verlangen oder vom Vertrag zurücktreten. Von einem Fehlschlagen der Nachbesserung ist erst auszugehen, wenn dem Lieferer hinreichend die Gelegenheit zur Nachbesserung oder Ersatzlieferung eingeräumt wurde, ohne dass der gewünschte Erfolg erzielt wurde, wenn die Nachbesserung oder Ersatzlieferung vom Lieferer verweigert oder unzumutbar verzögert wird, wenn begründete Zweifel hinsichtlich der Erfolgsaussichten bestehen, oder wenn eine Unzumutbarkeit aus sonstigen Gründen vorliegt.

(5) Die Haftung des Lieferers für leicht fahrlässige Pflichtverletzung wird ausdrücklich ausgeschlossen, sofern es sich nicht um vertragswesentliche Pflichten, Schäden aus der Verletzung des Lebens, des Körpers oder der Gesundheit oder Garantien handelt oder Ansprüche nach dem Produkthaftungsgesetz berührt sind. Gleiches gilt für Pflichtverletzungen der Erfüllungsgehilfen des Lieferers.

(6) Schadensersatzansprüche, welche auf leicht fahrlässigen Pflichtverletzungen des Lieferers beruhen sowie sonstige vertragliche Ansprüche gegen den Lieferer verjähren ein Jahr nach Ablieferung der Sache. Sind vertragswesentliche Pflichten, Schäden aus der Verletzung des Lebens, des Körpers oder der Gesundheit, weitergehende Garantien oder Ansprüche nach dem Produkthaftungsgesetz betroffen, gelten die gesetzlichen Fristen.

(7) Nicht vorhersehbare, vertragsuntypische Schäden sind, soweit nicht die Ausschlussbestände gemäß § 7 (5) gelten, von der Haftung ausgeschlossen.

## § 8 Anwendbares Recht, Erfüllungsort und Gerichtsstand

(1) Für diese Verkaufs- und Lieferbedingungen und die gesamten Rechtsbeziehungen zwischen dem Besteller und dem Lieferer gilt das Recht der Bundesrepublik Deutschland unter Ausschluss von UN-Kaufrecht.

(2) Erfüllungsort ist der Sitz des Lieferers (Reiskirchen).

(3) Im Geschäftsverkehr mit Kaufleuten, juristischen Personen des öffentlichen Rechts oder bei öffentlich-rechtlichem Sondervermögen ist bei Klagen Gerichtsstand Gießen. Dies gilt auch für Klagen im Wechsel- und Scheckprozess. Gießen gilt auch dann Gerichtsstand dem Lieferer und Besteller als vereinbarter Gerichtsstand, falls der Besteller keinen allgemeinen Gerichtsstand in der Bundesrepublik Deutschland hat.

## § 9 Rücknahme

(1) Eine Rücknahme erfolgt nur in Ausnahmefällen und nach vorheriger Vereinbarung und nach Erteilung einer Rückwaren-Bearbeitungsnummer. Es werden mindestens 20 % Kostenanteil vom Warenwert, bzw. bei einem Warenwert unter € 50,- eine Pauschale von € 10,- an der Gutschrift abgesetzt. Die Ware muss in einem wiederverkaufsfähigen Zustand und originalverpackt (mindestens in Folie verpackt) sein. Sonderformteile und gedrückte Rohrbogen sind generell von der Rücknahme ausgeschlossen.

## Section 1 Scope of Application

(1) The services and offers of Bänninger Kunststoff-Produkte GmbH (hereinafter known as the Supplier) are performed exclusively on the basis of these terms and conditions of sale and delivery. These terms and conditions shall also apply to all future business transactions with the contract partner (hereinafter known as the Buyer), even if they have not been expressly agreed for each transaction. The Supplier does not recognize the application of the Supplier's General Terms and Conditions of Business deviating from these terms and conditions of sale and delivery, unless the Supplier has expressly agreed in writing to their application.

(2) Any and all agreements which have reached between the Supplier and the Buyer for the performance of this contract have been recorded in writing in this contract. Additional oral agreements have not been concluded between the Supplier and the Buyer.

(3) These terms and conditions of sale and delivery shall, at the latest, be deemed accepted upon acceptance of the goods or service by the Buyer.

(4) These terms and conditions of sale and delivery are applicable only with respect to companies in the sense of Section 310 BGB (Civil Code).

## Section 2 Offer, Conclusion of Contract and Guarantee

(1) Any and all offers submitted by the Supplier are non-binding. Statements of acceptance and any and all orders shall not be legally effective unless confirmed in writing by the Supplier. If the Supplier does not send an order confirmation, the contract shall be deemed concluded if the Supplier delivers pursuant to the order and the Buyer accepts the goods.

(2) Drawings, pictures, dimensions, weights or other performance data contained in tables, advertising brochures, catalogues or similar documents from the Supplier are binding only if expressly agreed in writing.

(3) The Supplier shall be deemed to have given a guarantee only if and when the Supplier has designated in writing the relevant property as "guaranteed"

## Section 3 Delivery Deadlines and Delivery Periods

(1) Delivery periods shall be binding only if expressly agreed in writing. Any and all other delivery deadlines are merely non-binding or approximate delivery dates or periods, which the Supplier will strive to observe.

(2) Delivery periods begin on the day of dispatch of the order confirmation by the Supplier, but not until all details of the performance of the delivery have been clarified and any and all conditions to be met by the Buyer have been fulfilled. If the Buyer requests changes after placing the order, a new delivery period shall commence upon confirmation of the change by the Supplier.

(3) Deliveries may be made before the lapse of the delivery period. The Supplier may forego sending an order confirmation if the goods are delivered immediately. In these cases, the confirmation may be replaced by a delivery note.

(4) The day of notification of readiness for dispatch, in other cases the day of dispatch of the goods, shall be deemed the delivery day. Deliveries ordered by call-up shall be accepted no later than six months after the order confirmation.

(5) The Supplier is entitled to make partial deliveries. Each and every partial delivery shall be deemed a separate and independent transaction.

(6) If the Supplier is in default of delivery, the Buyer must first grant to the Supplier a reasonable extension period. If this extension period lapses in vain, the Buyer may assert his rights according to, and subject to the conditions in, Sections 280, 281, 284, 286, 323 BGB.

(7) If, due to reasons for which the Supplier is not responsible, the Supplier's own suppliers do not perform deliveries or services, or do not perform them correctly, or do not perform them in due time, or in the event of incidents of force majeure, the Supplier shall notify the Buyer thereof in writing in due time. In these cases, the period shall be extended by the duration of the hindrance. The following circumstances are the equivalent of force majeure: industrial actions, intervention by government authorities, energy and raw material shortages, transport bottlenecks through no fault of the Supplier, operational disruptions through no fault of the Supplier such as fire, water damage and machine malfunctions, and any and all other hindrances which were, when viewed objectively, not culpably caused by the Supplier. If a delivery date or a delivery period has been agreed as binding, and if the agreed delivery date or the agreed delivery period is exceeded by more than two months as a consequence of various events, the Buyer is entitled to cancel the part of the contract which has not been fulfilled.

## Section 4 Shipment and Transfer of Risk

(1) In the absence of written, deviating agreements, shipment shall be effected without insurance and at the risk and expense of the Buyer. Selection of the transport route and the means of transport shall be at the Supplier's discretion. The risk of accidental perishing or of accidental deterioration of the goods shall be transferred to the Buyer upon surrender of the goods of the delivery to the Buyer, the forwarding agent, the carrier or other company designated for performance of the shipment, at the latest upon the goods leaving the Supplier's plant/warehouse.

(2) To the extent that the shipment of the goods is delayed because the Supplier, as a consequence of whole or partial default of payment of the Buyer, exercises his right of retention, or due to other reasons for which the Buyer is responsible, the risk shall be transferred to the Buyer no later than on the date of notification of readiness for shipment.

(3) Goods which have been reported as ready for shipment must be called up without delay. Otherwise, the Supplier is entitled at his discretion to ship the goods or to store them at the Buyer's expense and risk.

(4) Installation instructions for the delivered goods can be obtained on the Supplier's home page ([www.baenninger.de](http://www.baenninger.de)). The Buyer must notify the Supplier if he wishes to have the installation instructions in print form. In this case, the Supplier will provide the installation instructions to the Buyer.

## Section 5 Prices and Terms and Conditions of Payment

(1) The Supplier's invoices are due and payable net within 30 days of the invoice date. A cash discount of 3% is granted for payments made within 10 days, to the extent that the Buyer is not in default of payment of receivables. The day the payment is credited to the Supplier's account is definitive. Interest for overdue payment at a rate of 8% above the current base rate will be charged on payments for which the Buyer is in default.

(2) Bills of exchange offered by the Buyer will be accepted by the Supplier only on account of performance and after express agreement and on the condition that said bills can be discounted. Discount fees will be charged as of the due date of the amount of the invoice by the Supplier. For bills of exchange and cheques, the day of their redemption shall be deemed the day of payment.

(3) If the Buyer does not observe the terms and conditions of payment, or if circumstances become known which in the reasonable commercial judgment of the Supplier give rise to justified doubts in the creditworthiness of the Buyer, including any such circumstances already existing at the time of the conclusion of the contract which, however, the Supplier was not aware of or had no cause to be aware of, the Supplier is entitled, without prejudice to further statutory rights, to discontinue further work on pending contracts or to suspend delivery, and to request advance payment or submission of appropriate collateral for outstanding deliveries, and, after the fruitless lapse of a reasonable period for the submission of said collateral – without prejudice to further statutory rights – to cancel the contract. The Buyer is obligated to compensate the Supplier for any and all damage resulting from the non-performance of the contract.

(4) The Buyer may set off any counterclaims against the Supplier only if said counterclaims have been legally and finally determined, are undisputed or have been acknowledged by the Supplier. In addition, the Buyer is entitled to exercise a right of retention only to the extent that his counterclaim results from the same contractual relationship.

(5) If not otherwise indicated in the order confirmation, the Supplier's prices, which are always given in euros, are EXW (ex works/warehouse) plus the currently applicable value-added tax. Prices do not include packaging, freight, postage and insurance. Said expenses shall be billed separately.

(6) In the event of a significant change in cost factors, such as an increase in material procurement costs, wage and ancillary wage costs and energy costs, the Supplier is entitled unilaterally to raise the price if there is a period of four months between the conclusion of the contract with the Buyer and the delivery of the goods.

## Section 6 Retention of Title

(1) The Supplier retains title of ownership to the delivered goods (hereinafter known as the "purchase item") until any and all of the Supplier's receivables from the business relationship with the Buyer have been settled.

(2) The Buyer shall at his own expense provide insurance cover for the purchase item, in particular for fire and theft.

(3) The Buyer is entitled to sell further the purchase item in the course of ordinary business. Other disposals, in particular assignments or granting of equitable liens, are not permitted.

(4) If, upon further sale, the purchase item is not paid immediately in full by the third-party purchaser, the Buyer is obligated to sell further to the third-party purchaser only subject to retention of title.

(5) The right to further sale of the purchase item expires if the Buyer suspends payment or is in default of payment to the Supplier.

(6) The Buyer hereby assigns in advance to the Supplier any and all claims, including collateral and subsidiary rights, in the amount of the final invoice amount, including VAT, which arise for the Buyer against his customer or third parties from the further sale of the purchase item, independently of whether the purchase item is sold further with or without processing.

(7) In the event of attachments or other intervention by third parties, the Buyer shall notify the Supplier in writing immediately, providing any relevant documents, so that the Supplier can file protective action.

(8) Any processing or transformation of the purchase item shall at all times be performed on behalf of the Supplier. If the purchase item is processed together with other objects which do not belong to the Supplier, the Supplier shall acquire co-ownership in the new object in the ratio of the invoice value of the purchase item to the other processed objects at the time of the processing. Otherwise, the provisions applicable to the purchase item delivered subject to retention of title shall apply to the object resulting from the processing. If the purchase item is inseparably mixed with other objects which do not belong to the Supplier, the Supplier shall acquire co-ownership in the new object in the ratio of the invoice value of the purchase item to the other mixed objects at the time of the mixing. If the mixing occurs in such a manner that the Buyer's object shall be deemed the main object, it shall be deemed as agreed that the Buyer has assigned to the Supplier proportional co-ownership. The Buyer shall keep the resulting sole ownership or co-ownership in safe custody on the Supplier's behalf.

(9) To secure the Supplier's receivables due from the Buyer, the Buyer shall also assign to the Supplier the claims which arise for the former against third parties from the combining of the purchase item with land.

(10) The Supplier promises, at the request of the Buyer, to release collateral to which the former is entitled to the extent that the realizable value of the Supplier's collateral exceeds the amount of the receivables being secured by more than 20%. The selection of the collateral for release is at the discretion of the Supplier.

## Section 7 Warranty / Liability

(1) The Buyer undertakes to examine the delivered goods for obvious defects which are detectable without special effort. Obvious defects include, for example, substantial, easily visible damage to the goods. This obligation also covers cases in which a different object or inadequate quantities are delivered. Complaint of such obvious defects shall be made to the Supplier no later than two weeks after delivery. Moreover, complaint of obvious defects must be made to the shipping company upon delivery; the Buyer shall request the shipping company to record the defects.

(2) Complaint of defects which do not become apparent until a later date must be submitted to the Supplier no later than two weeks following detection by the user. In the event of the Buyer's failure to fulfil his obligations to examine the goods and submit complaint, the goods shall be deemed as accepted with knowledge of the pertinent defects.

(3) Defects in the delivered object shall be eliminated by the Supplier no later than one year after delivery following appropriate notification by the Buyer. The defects may be eliminated, at the discretion of the Buyer, by subsequent remedy free of charge or by substitute delivery. If substitute delivery is performed, the Buyer is obligated to return the defective object.

(4) If the defect cannot be eliminated within a reasonable period, or if the subsequent remedy or substitute delivery is deemed to have failed for other reasons, the Buyer may, at his discretion, request reduction of the price or cancel the contract. Subsequent remedy shall not be deemed to have failed unless the Supplier has been given adequate opportunity to perform subsequent remedy or substitute delivery without achieving the desired result, or unless the subsequent remedy or substitute performance is refused or delayed unreasonably by the Supplier, unless justified doubt regarding the prospects for success exist, or unless there are other reasons for hardship.

(5) Liability of the Supplier for breach of obligation due to slight negligence is expressly excluded, to the extent that said breach is not related to essential obligations of the contract, to injuries to life, body or health or to guarantees, or affects claims arising from the Product Liability Act. The above provision also applies to breach of obligation by vicarious agents of the Supplier.

(6) Damage compensation claims arising from Supplier's breach of obligations due to slight negligence as well as other contractual claims on the Supplier shall become time-barred one year after delivery of the object. The statutory periods of limitation apply to breach of obligations essential to the contract, damage from injury to life, body or health, further guarantees or claims arising from the Product Liability Act.

(7) Unforeseeable damage which is not typical for the contract is excluded from the liability, to the extent that exclusion circumstances in accordance with Section 7 (5) do not apply.

## Section 8 Proper Law, Place of Performance and Jurisdiction

(1) The law governing these terms and conditions of sales and all legal relationships between the Buyer and Supplier is the law of the Federal Republic of Germany, excluding the CISG.

(2) Place of performance is the Supplier's place of business (Reiskirchen).

(3) The courts of Giessen have jurisdiction for legal actions brought in relation to business with merchants, legal persons under public law or public law special funds. The above provision shall also apply with respect to legal actions regarding bills of exchange and cheques. The courts of Giessen shall also be agreed to have jurisdiction for Supplier and Buyer in the event that the Buyer is not subject to general jurisdiction in the Federal Republic of Germany.



## Section 9 Return



(1) A return may be made only in exceptional cases and only after prior agreement and assignment of a returned goods processing number. A share of costs of no less than 20% of the value of the goods, or if the value of the goods is below €50.00, a lump-sum charge of €10.00 will be deducted from the amount of the credit note. The goods must be in a resalable condition and in the original packaging (at least packaged in foil). Specially moulded parts and pressed pipe elbows are generally excluded from return.



**Bänninger**  
**Kunststoff-Produkte GmbH**

Postfach 1154  
D-35447 Reiskirchen, GERMANY

 +49 (0) 64 08 89-0  
 +49 (0) 64 08 67 56

 [info@baenninger.de](mailto:info@baenninger.de)  
 [www.baenninger.de](http://www.baenninger.de)

Presented by

